

Cake cutting, rental harmony and triangles

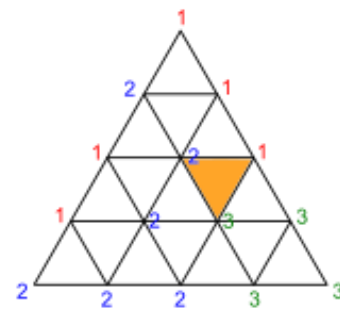

Rohit Vaish

Fair Division

Fair Division



Fair Division



Fair Division



Fair Division



Fair Division

Divisible



Fair Division

Divisible



Indivisible



Fair Division

Divisible



Indivisible



Fair Division

Divisible



Indivisible

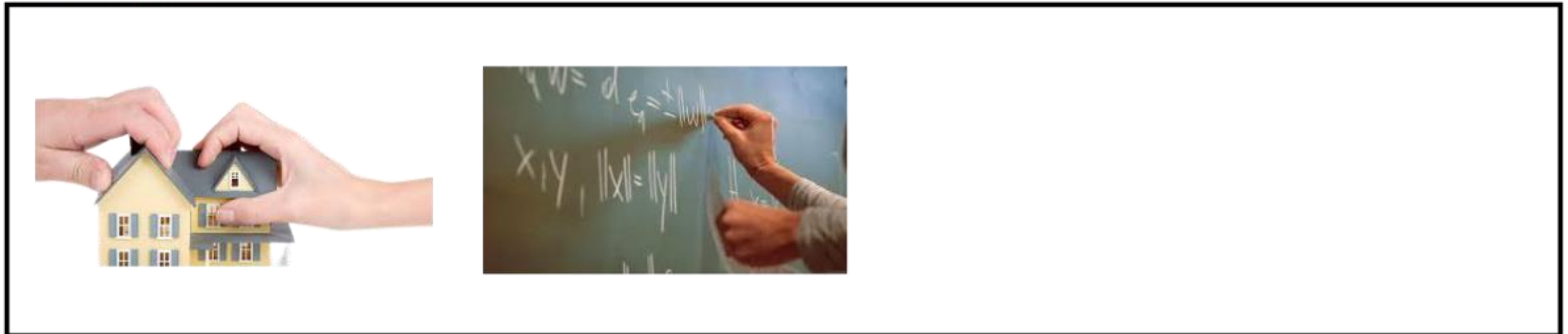

Fair Division

Divisible

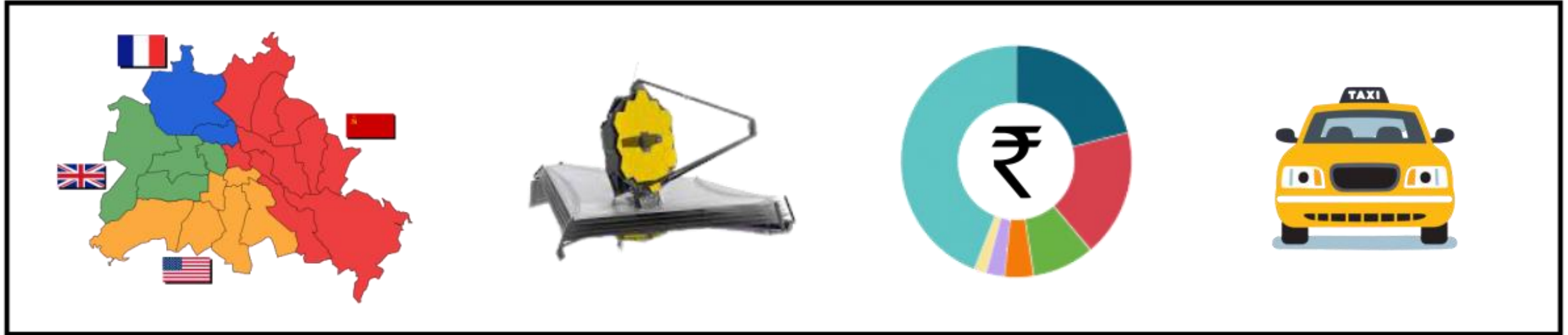

Indivisible



Fair Division

Divisible



Indivisible



Fair Division

Divisible



Indivisible

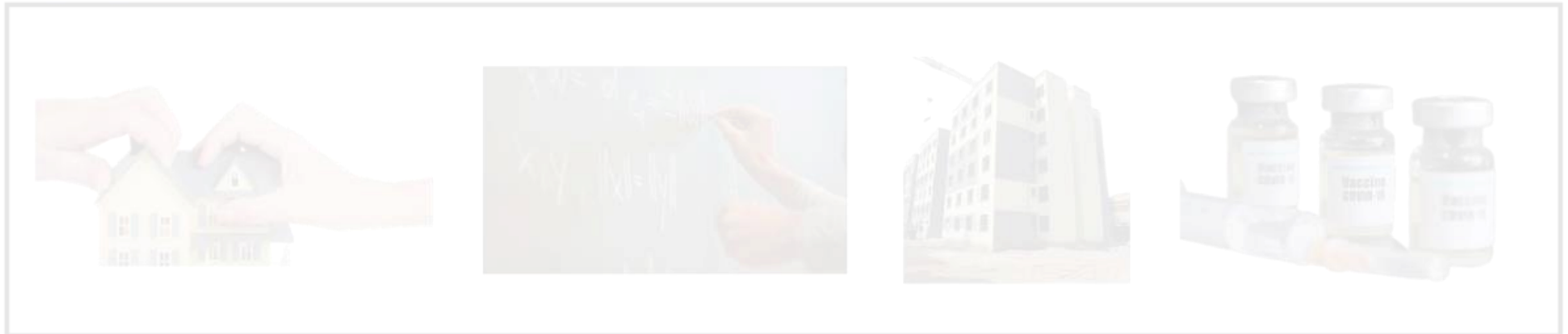

Cake Cutting

Rent Division

Cake Cutting

Rent Division



Divide the cake such that



Divide the cake such that



*I prefer my piece
over anyone else's*

Divide the cake such that

*I prefer my piece
over anyone else's*



*I prefer my piece
over anyone else's*

Divide the cake such that

*I prefer my piece
over anyone else's*

*I prefer my piece
over anyone else's*



*I prefer my piece
over anyone else's*

*I prefer my piece
over anyone else's*

Divide the cake such that

*I prefer my piece
over anyone else's*

*I prefer my piece
over anyone else's*



*I prefer my piece
over anyone else's*

*I prefer my piece
over anyone else's*

no kid envies another



I Cut, You Choose



I Cut, You Choose

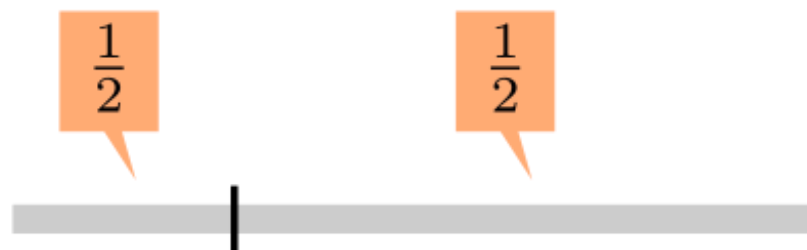

I Cut, You Choose

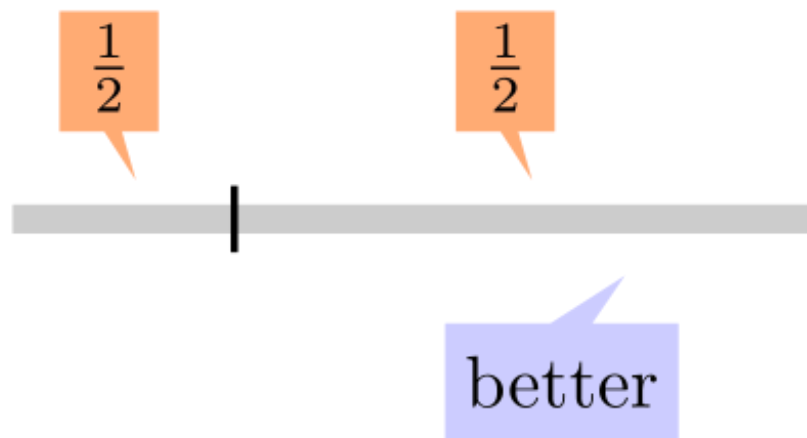

I Cut, You Choose

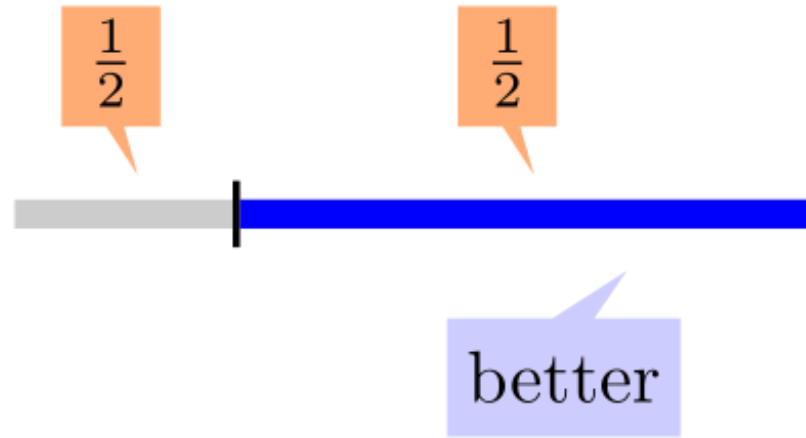

I Cut, You Choose

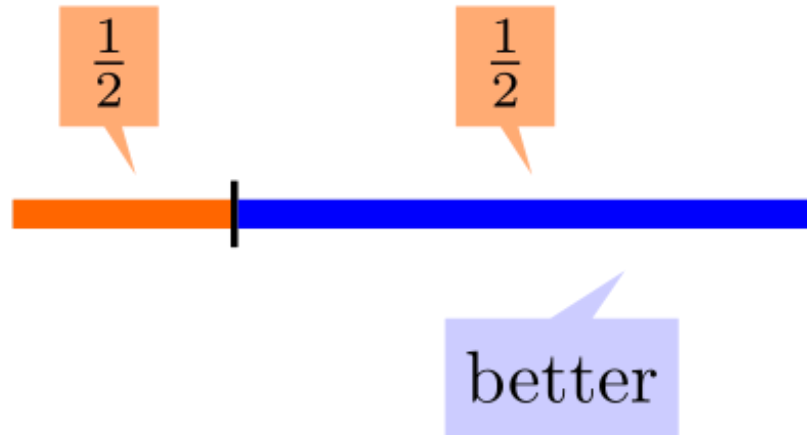

I Cut, You Choose

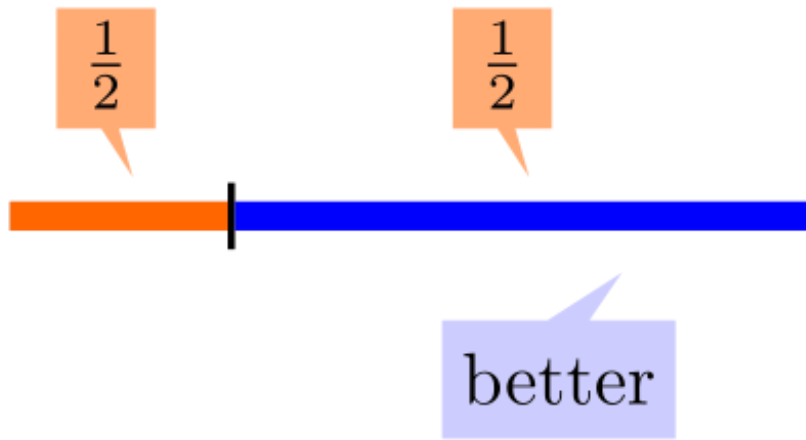

Not obvious for three or more kids

Cake Cutting

Rent Division

Cake Cutting

Rent Division



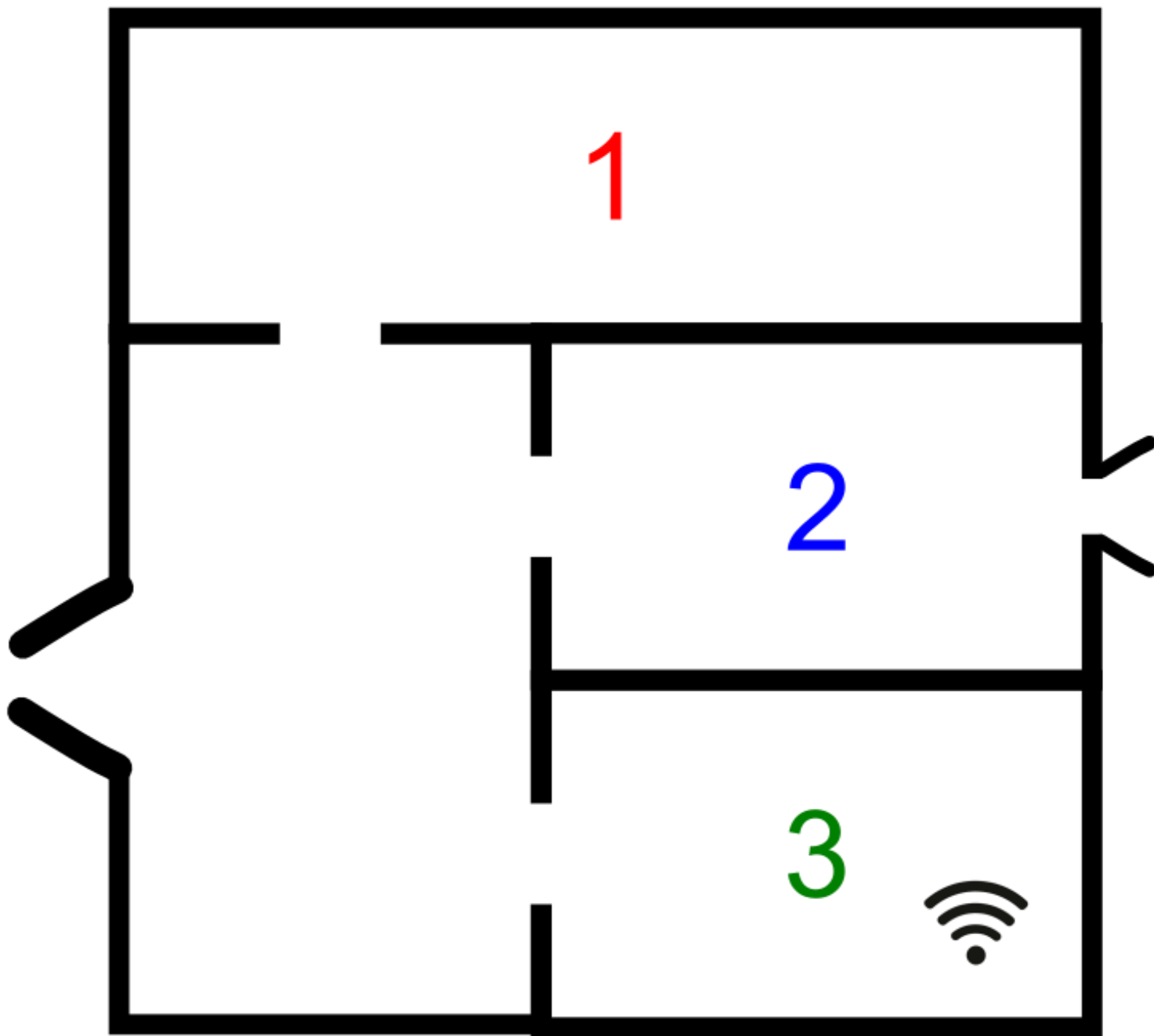

1

2

3



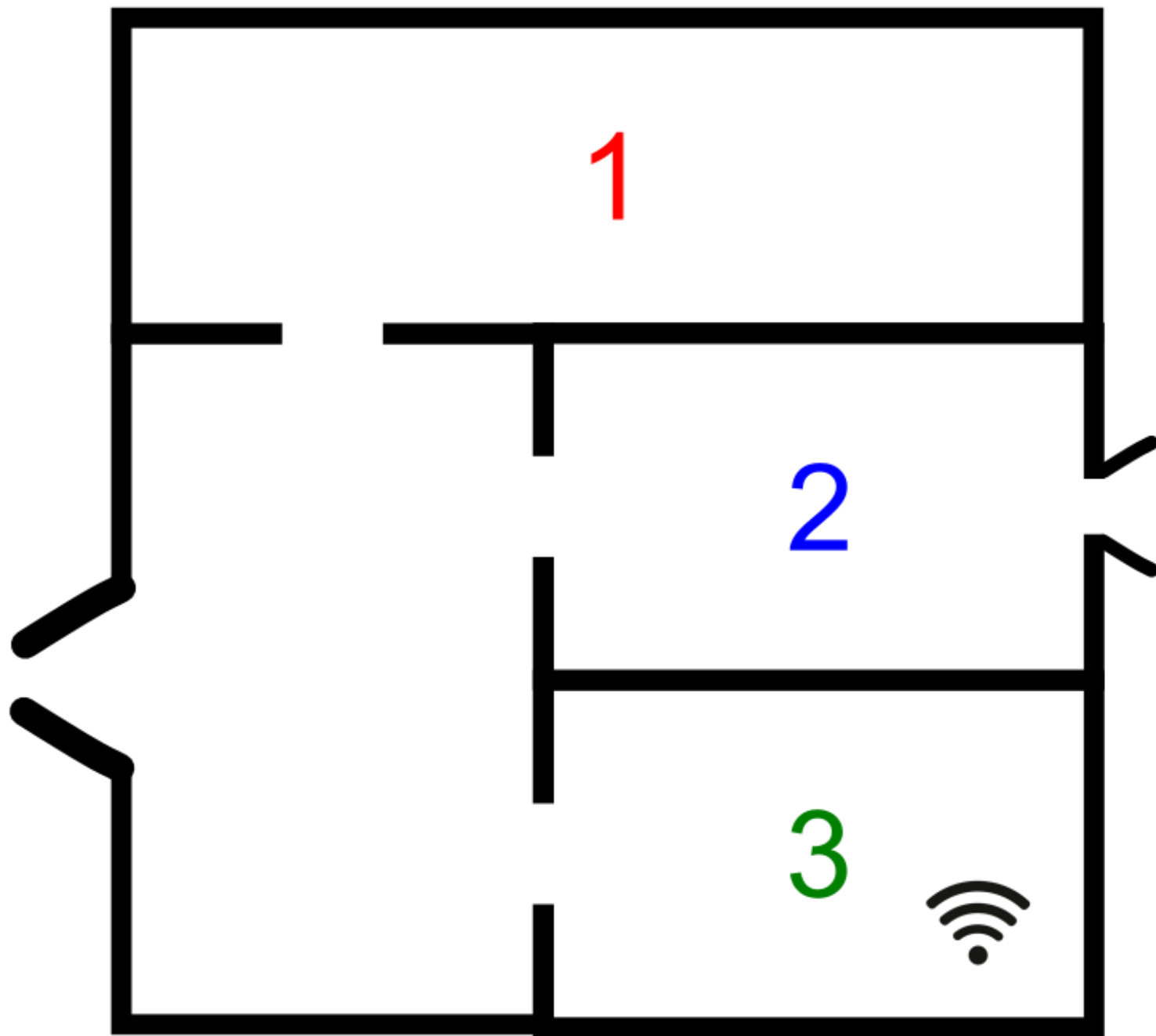

Rent
=
1000

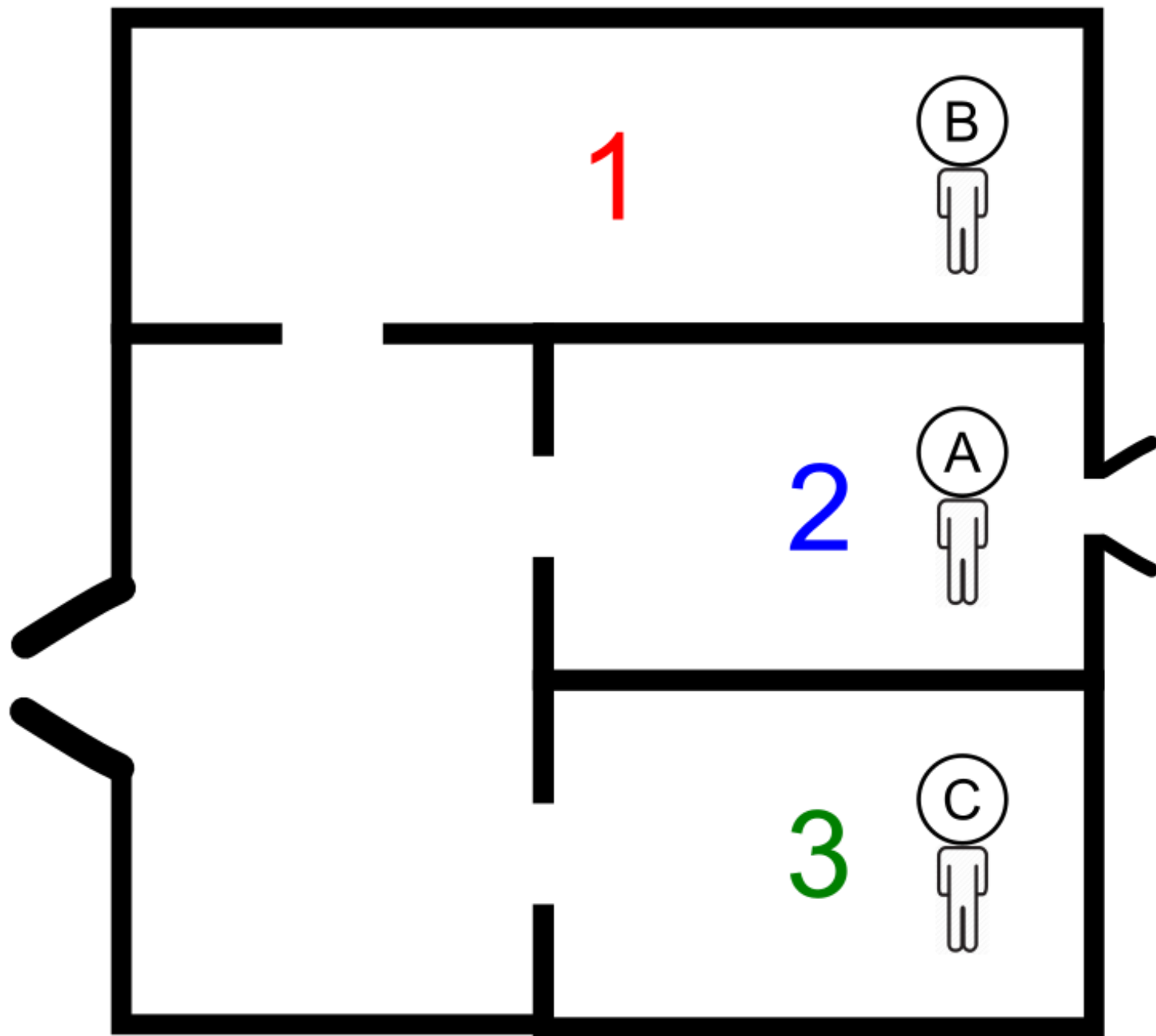

Rent
=
1000

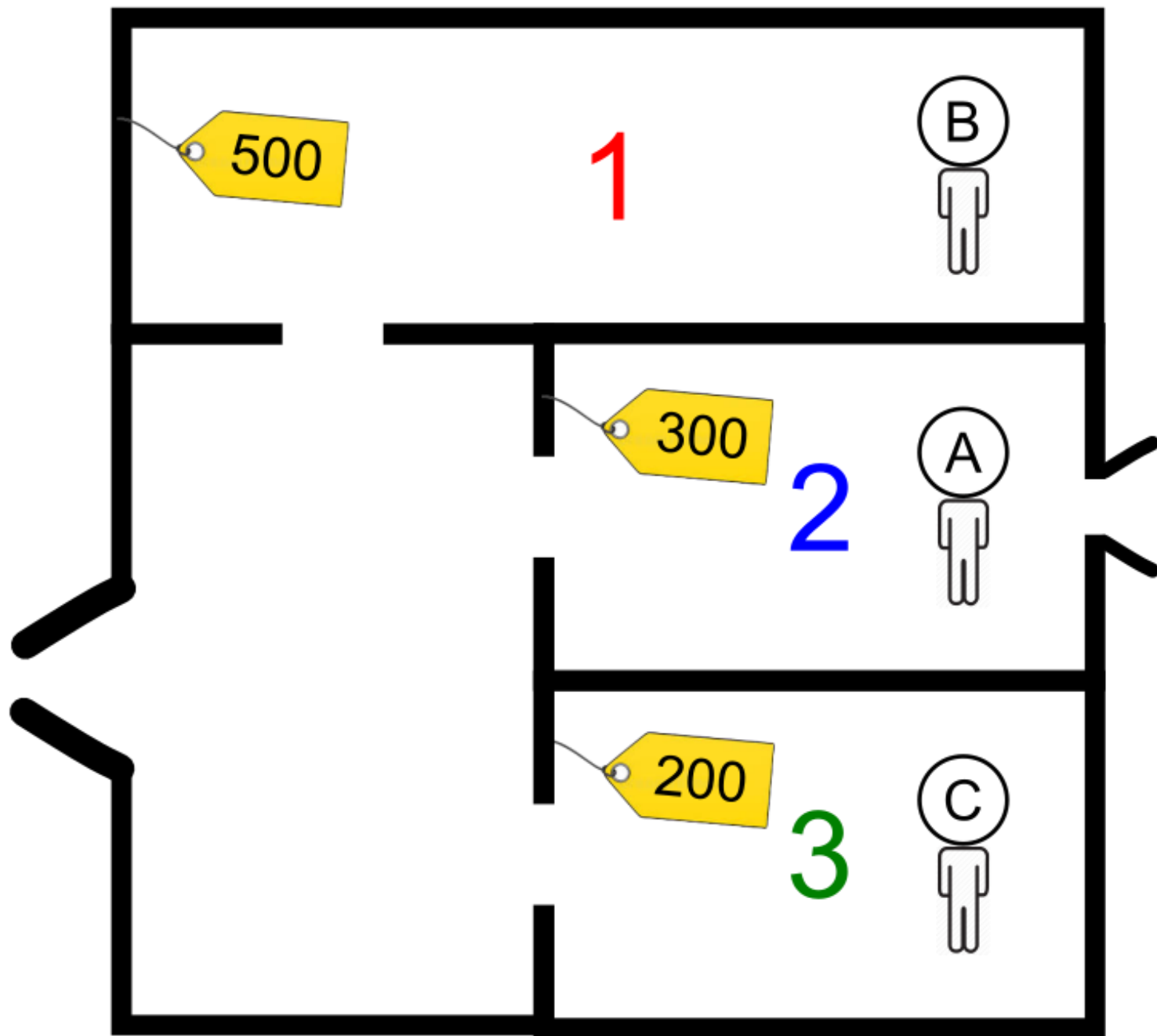

Rent
=
1000

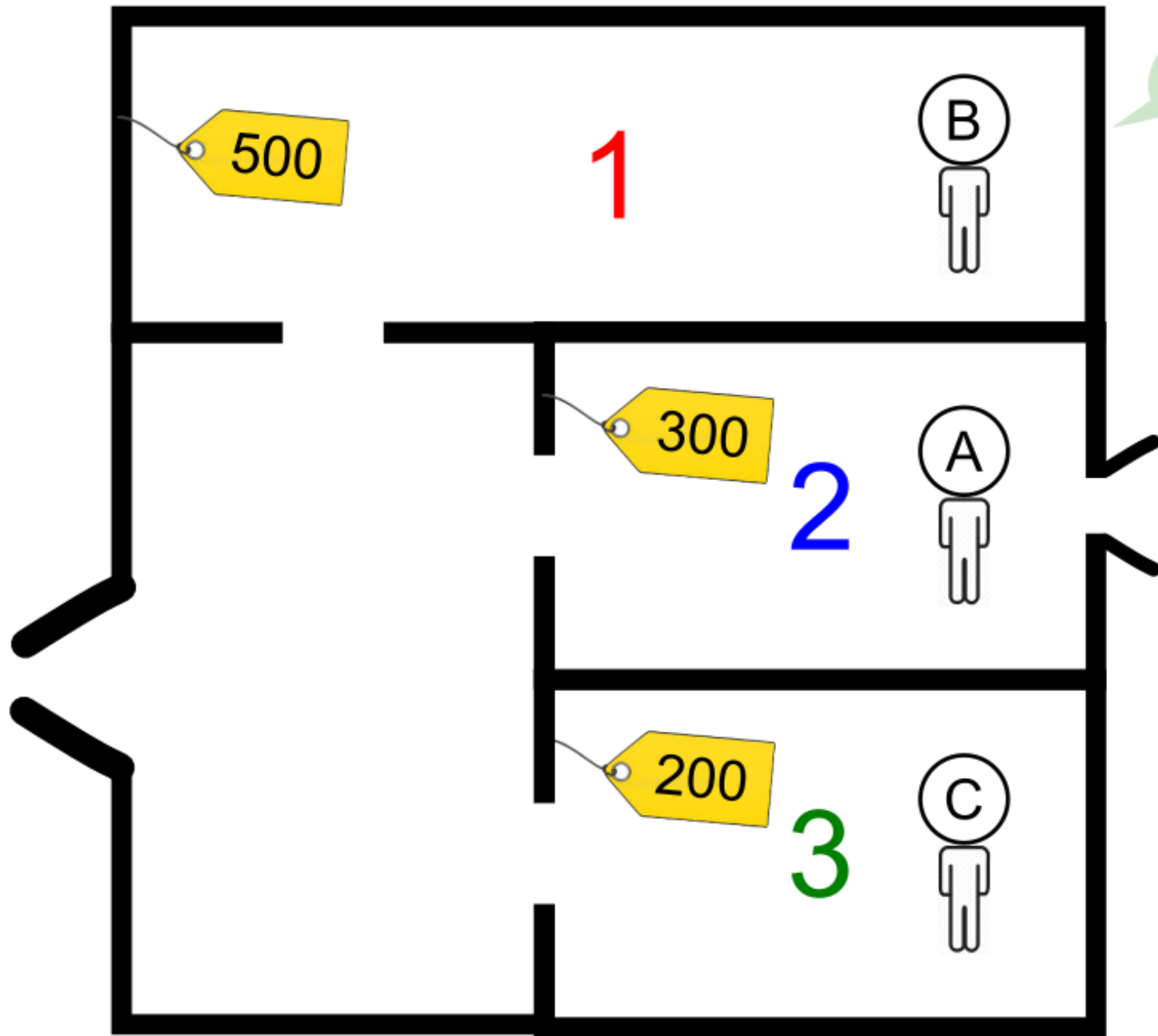

I like Room 1 for Rs. 500 over Room 2 for Rs. 300 and Room 3 for Rs. 200.

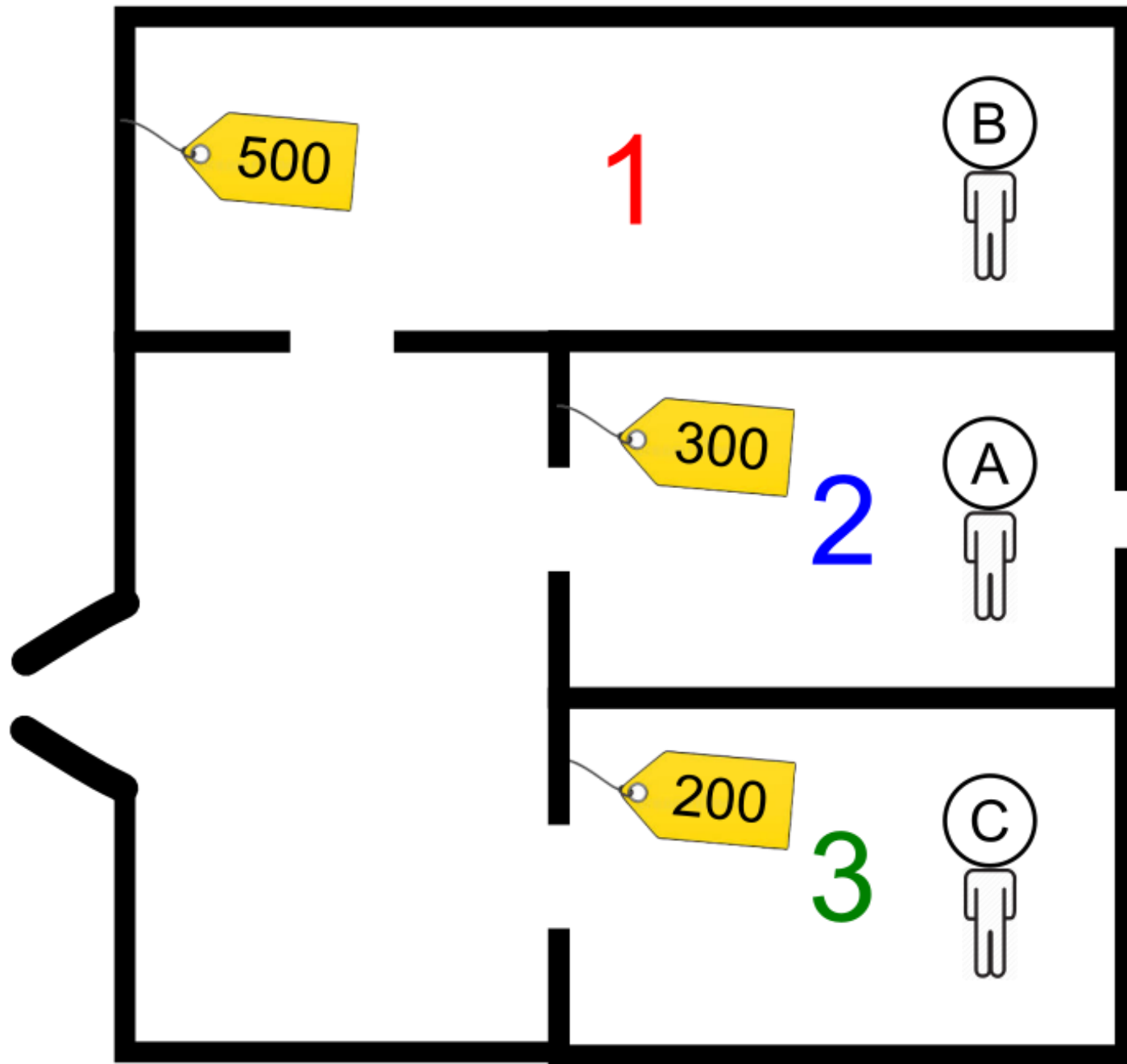

I like Room 1 for Rs. 500 over Room 2 for Rs. 300 and Room 3 for Rs. 200.

I like Room 2 for Rs. 300 over Room 1 for Rs. 500 and Room 3 for Rs. 200.

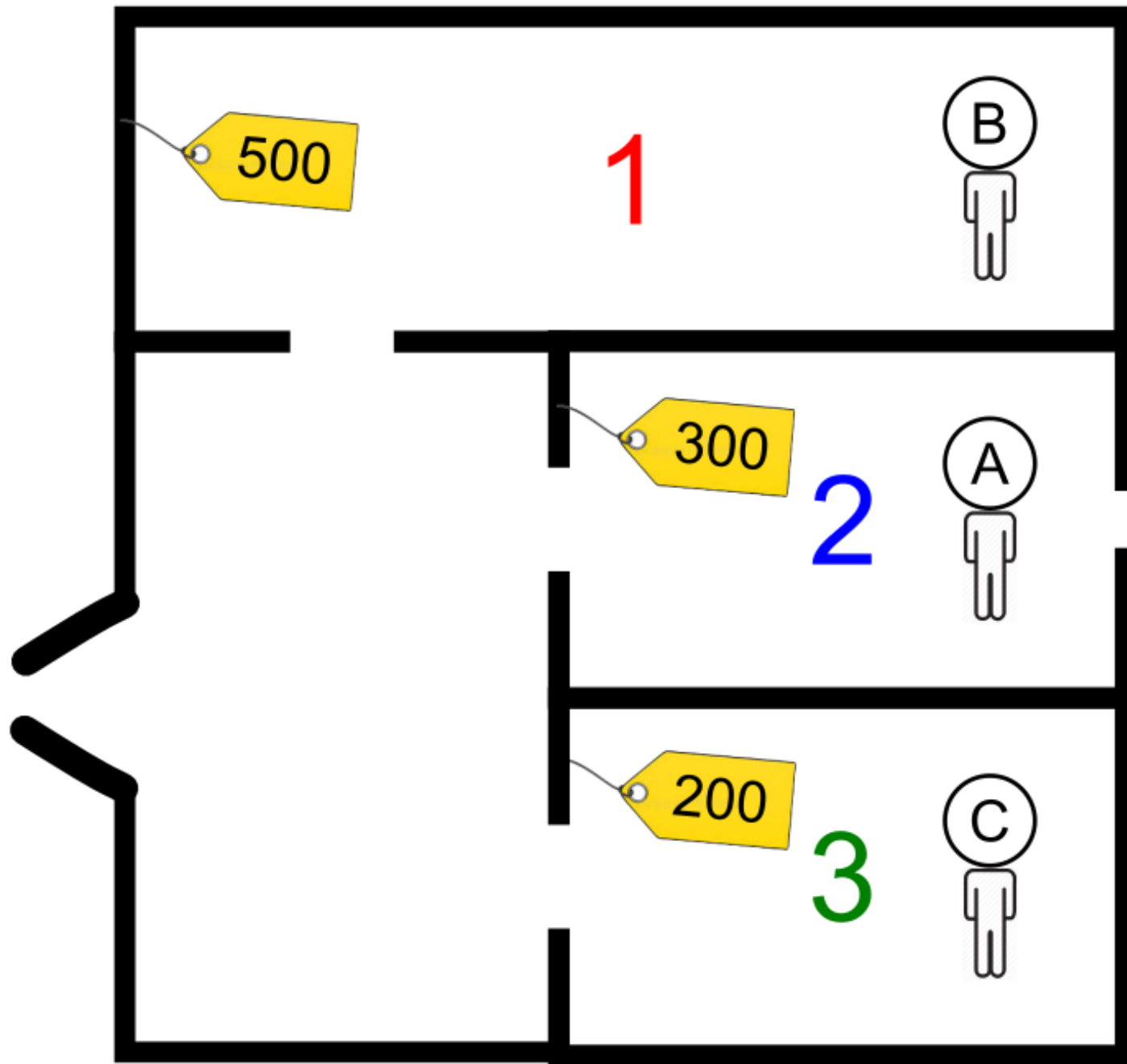

I like Room 1 for Rs. 500 over Room 2 for Rs. 300 and Room 3 for Rs. 200.

I like Room 2 for Rs. 300 over Room 1 for Rs. 500 and Room 3 for Rs. 200.

I like Room 3 for Rs. 200 over Room 1 for Rs. 500 and Room 2 for Rs. 200.

Envy-free rent division

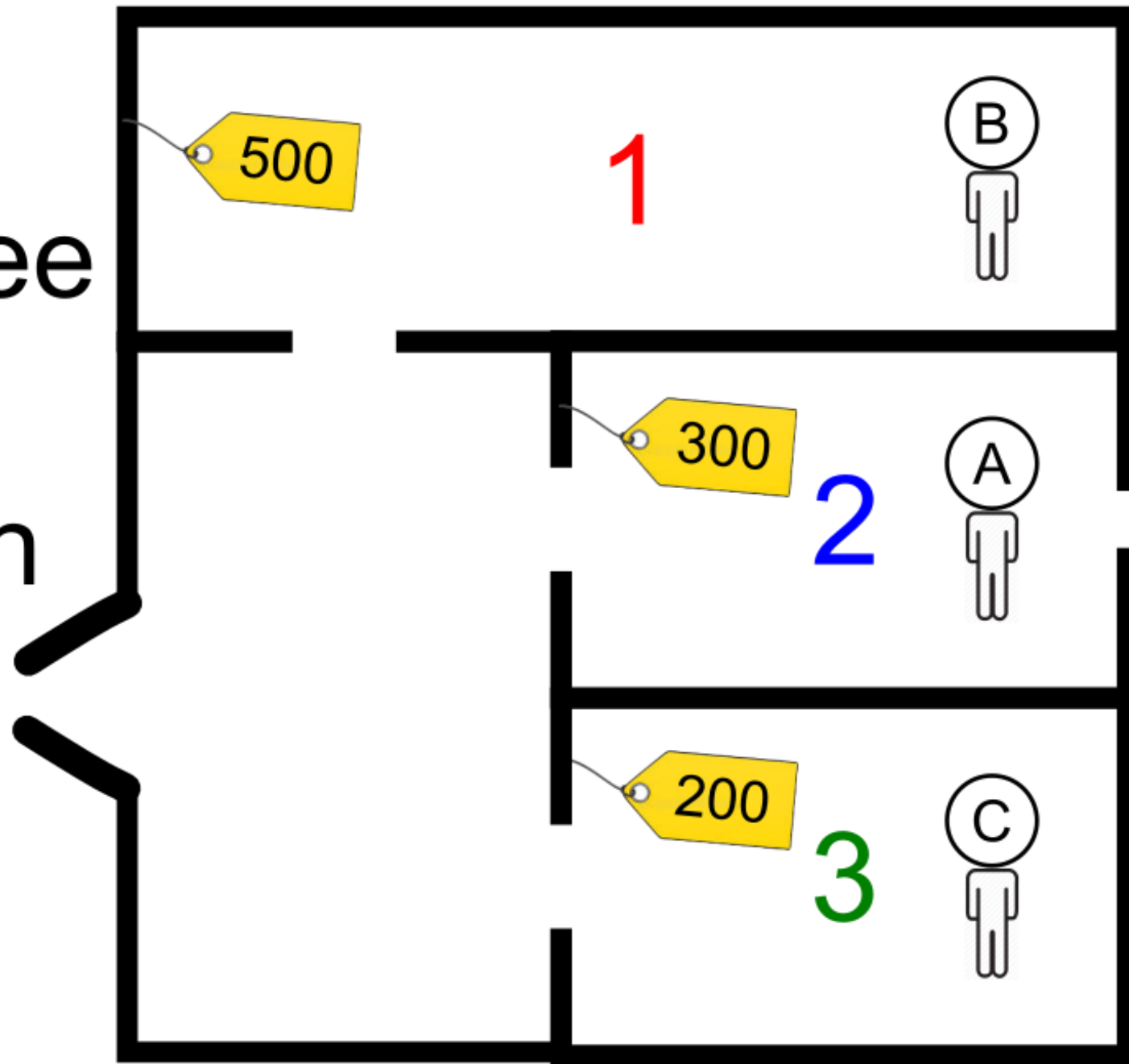

I like Room 1 for Rs. 500 over Room 2 for Rs. 300 and Room 3 for Rs. 200.

I like Room 2 for Rs. 300 over Room 1 for Rs. 500 and Room 3 for Rs. 200.

I like Room 3 for Rs. 200 over Room 1 for Rs. 500 and Room 2 for Rs. 200.

Cake Cutting

Rent Division

Triangles!

Cake Cutting

Rent Division

Sperner's Lemma

Sperner's Lemma

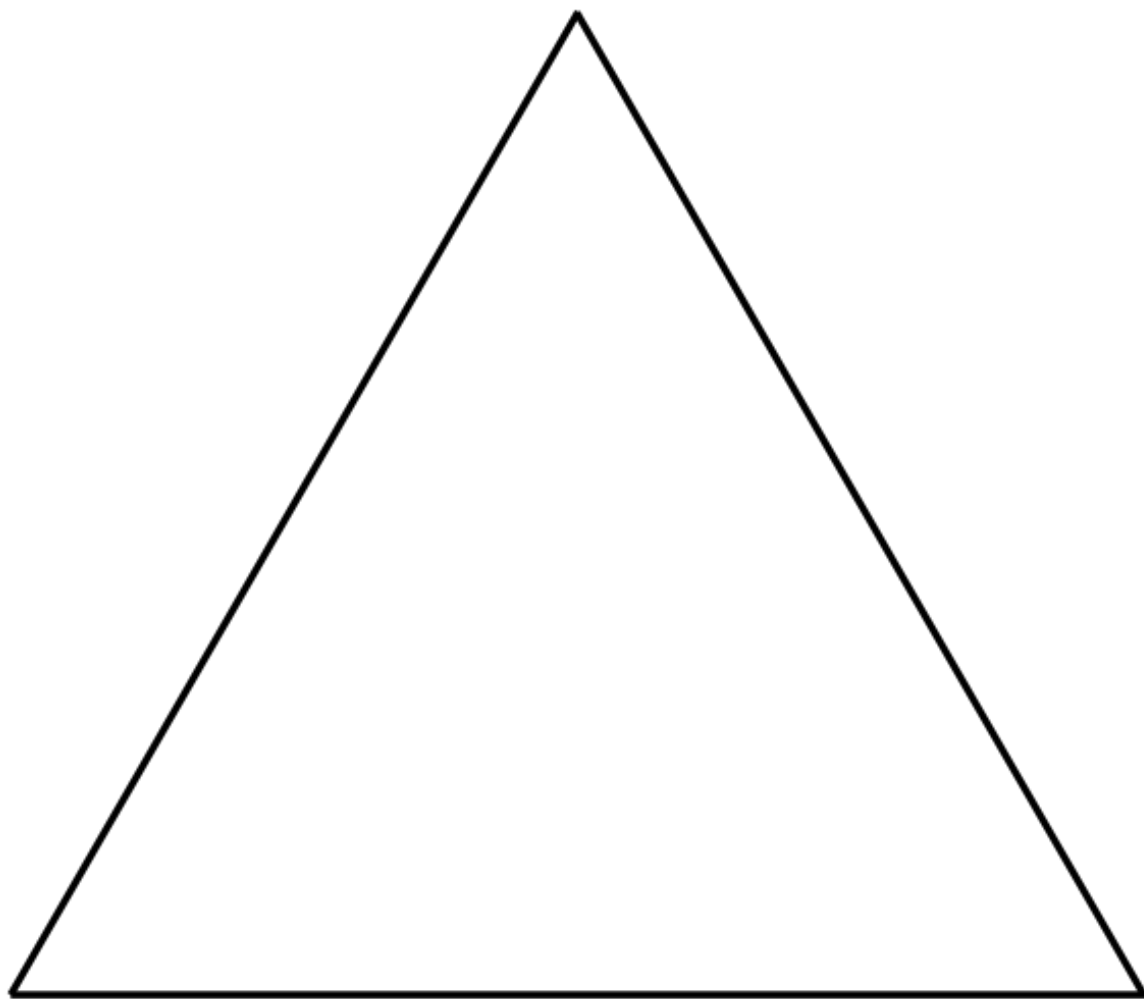

Sperner's Lemma

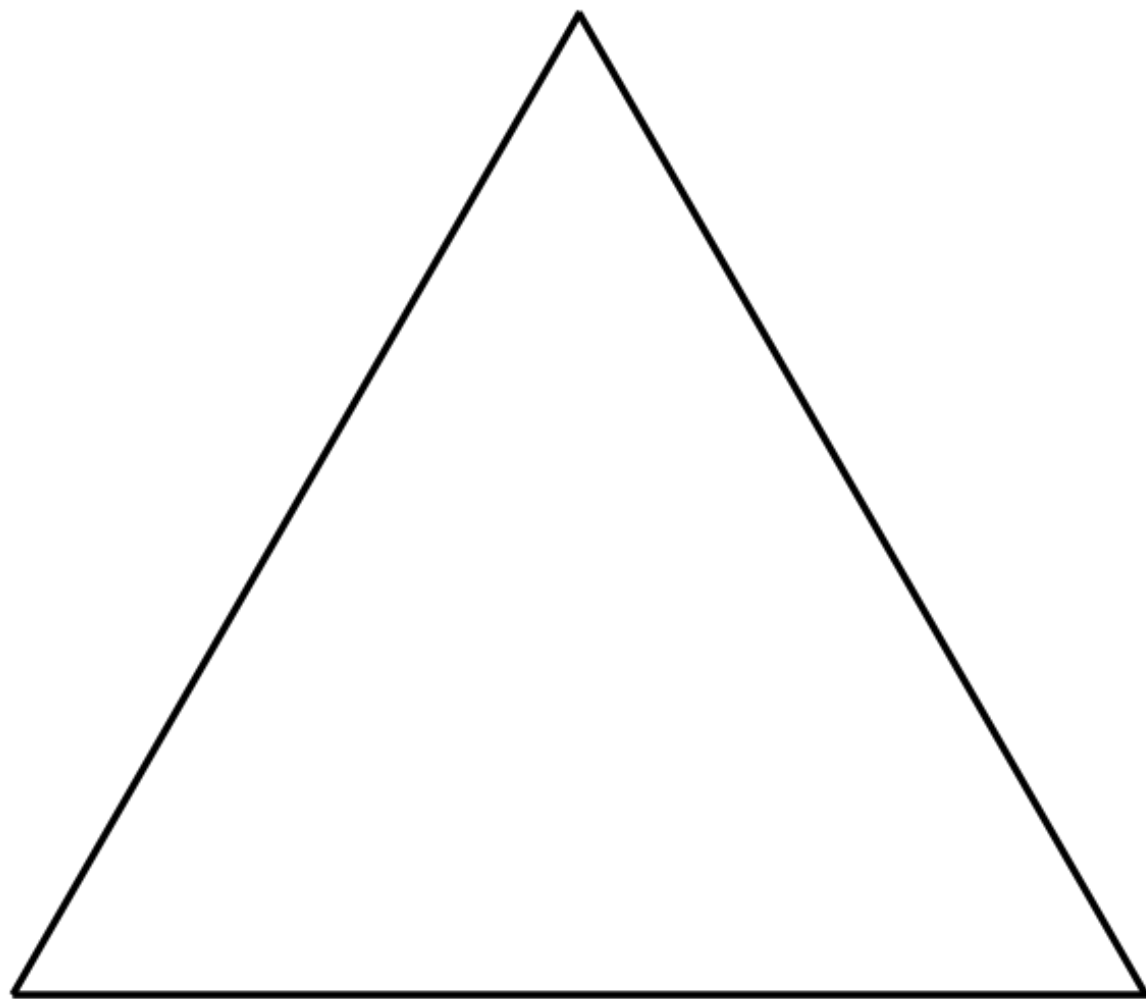

1. Triangulation into *elementary* triangles

Sperner's Lemma

1. Triangulation into *elementary* triangles

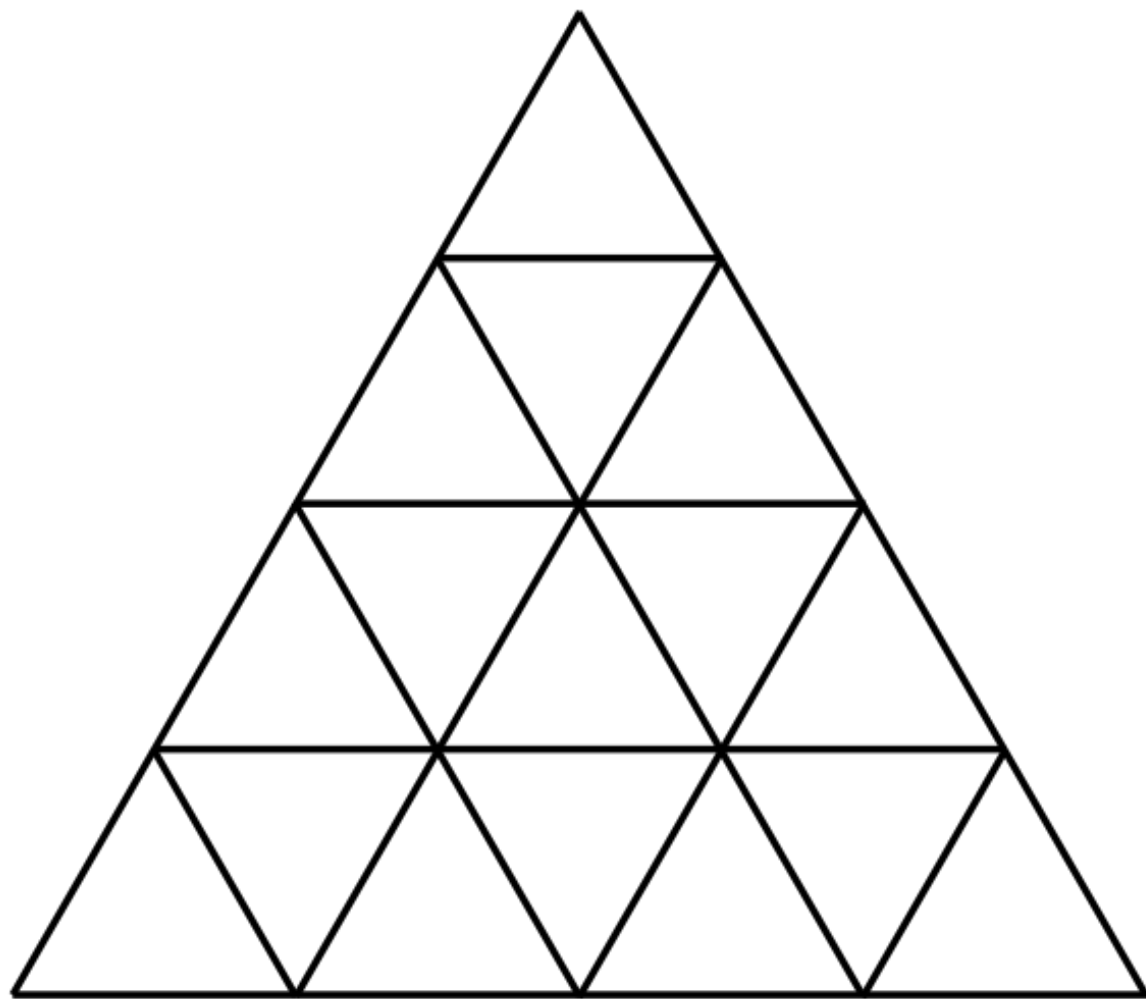

Sperner's Lemma

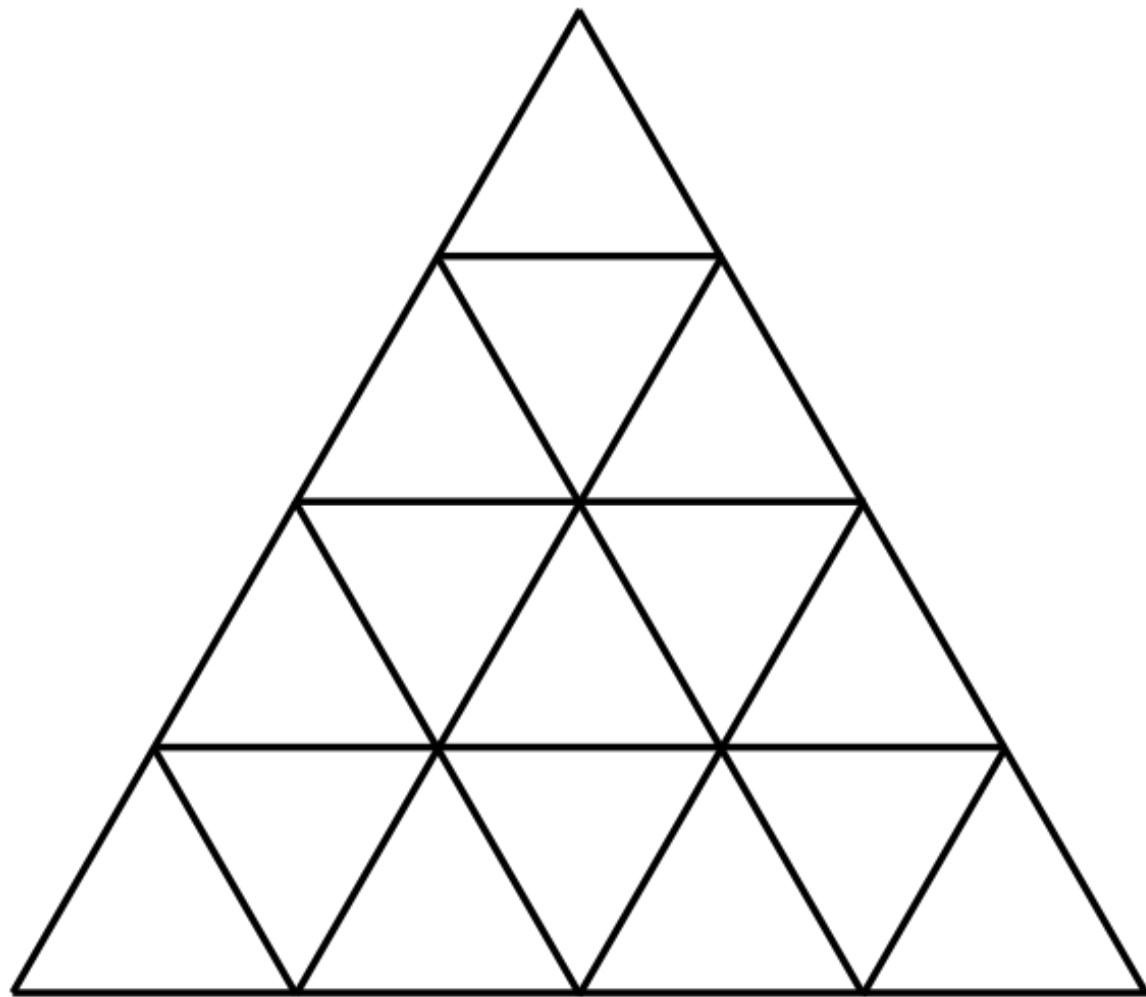

1. Triangulation into *elementary* triangles
2. Sperner labeling

Sperner's Lemma

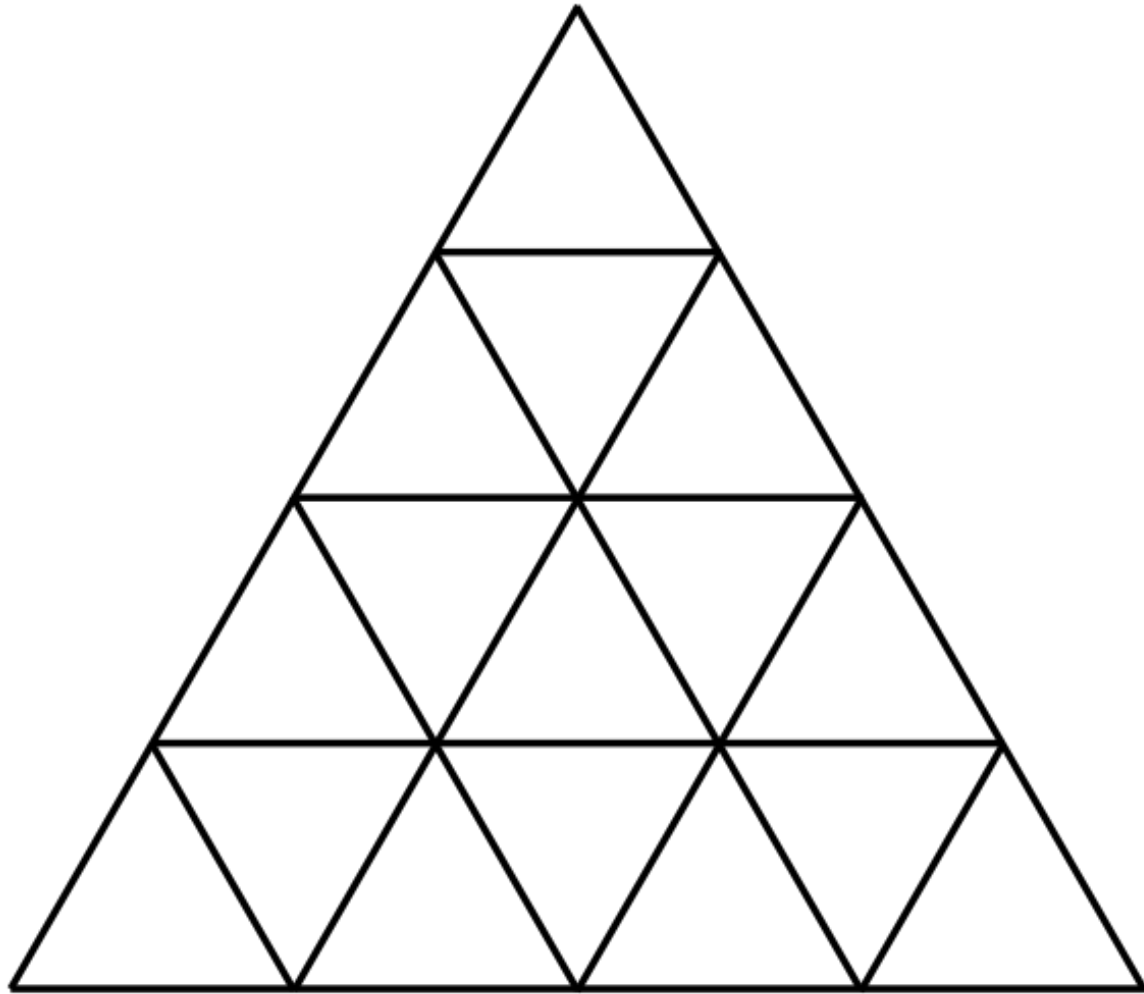

1. Triangulation into *elementary* triangles
2. Sperner labeling
 - Main vertices have distinct labels

Sperner's Lemma

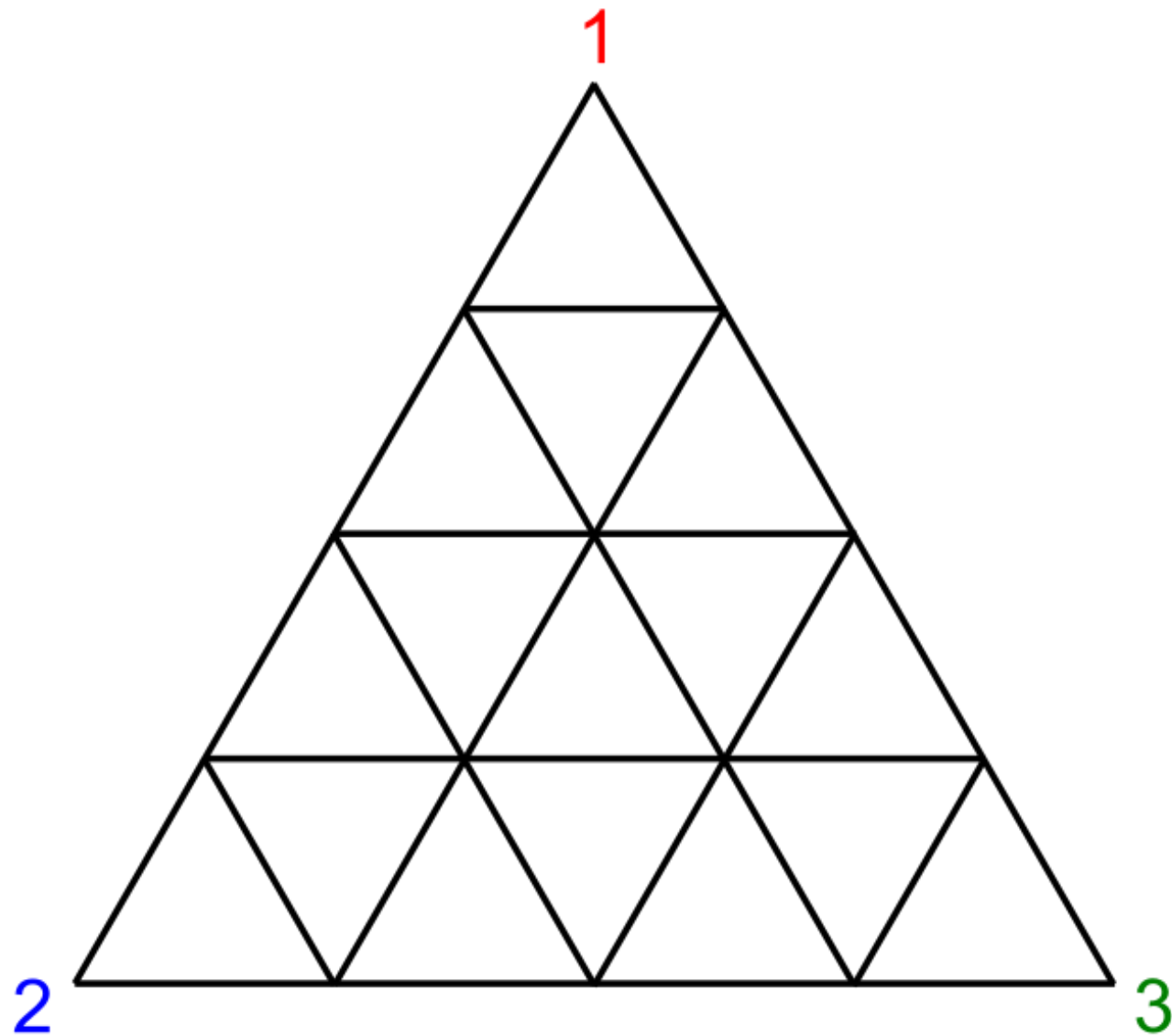

1. Triangulation into *elementary* triangles
2. Sperner labeling
 - Main vertices have distinct labels

Sperner's Lemma

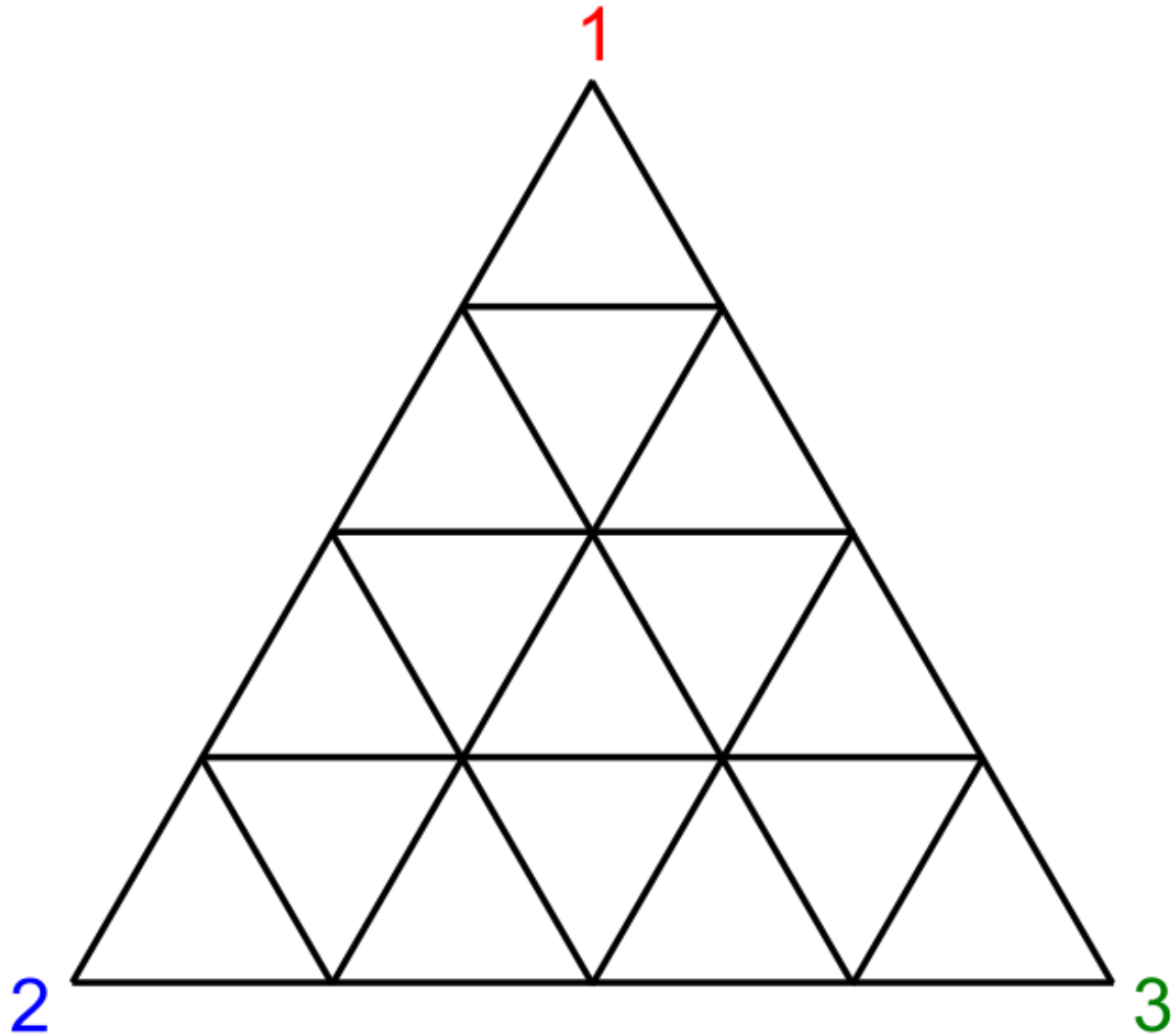

1. Triangulation into *elementary* triangles
2. Sperner labeling
 - Main vertices have distinct labels
 - Boundary vertices inherit the labels of the adjacent main vertices

Sperner's Lemma

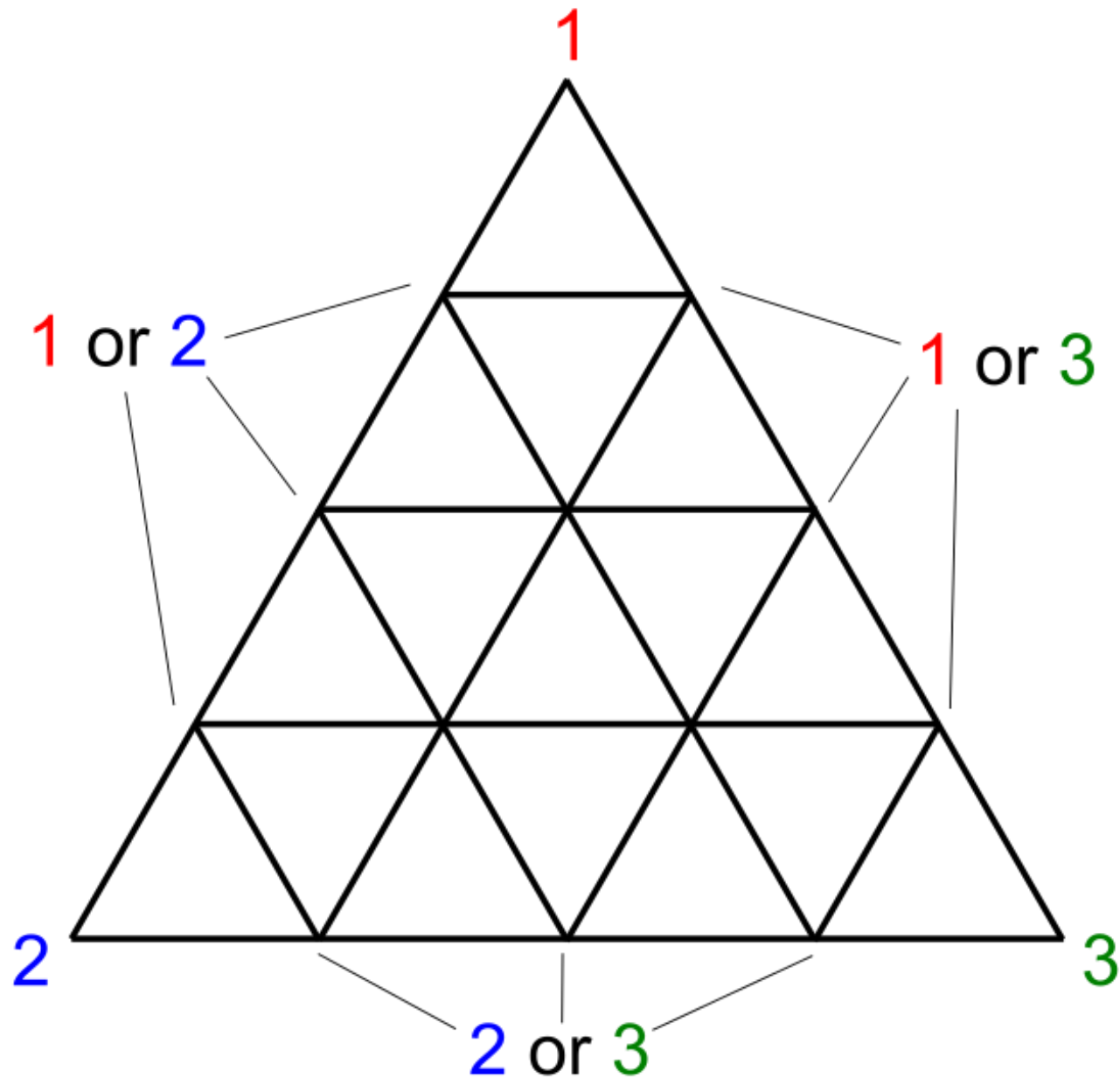

1. Triangulation into *elementary* triangles
2. Sperner labeling
 - Main vertices have distinct labels
 - Boundary vertices inherit the labels of the adjacent main vertices

Sperner's Lemma

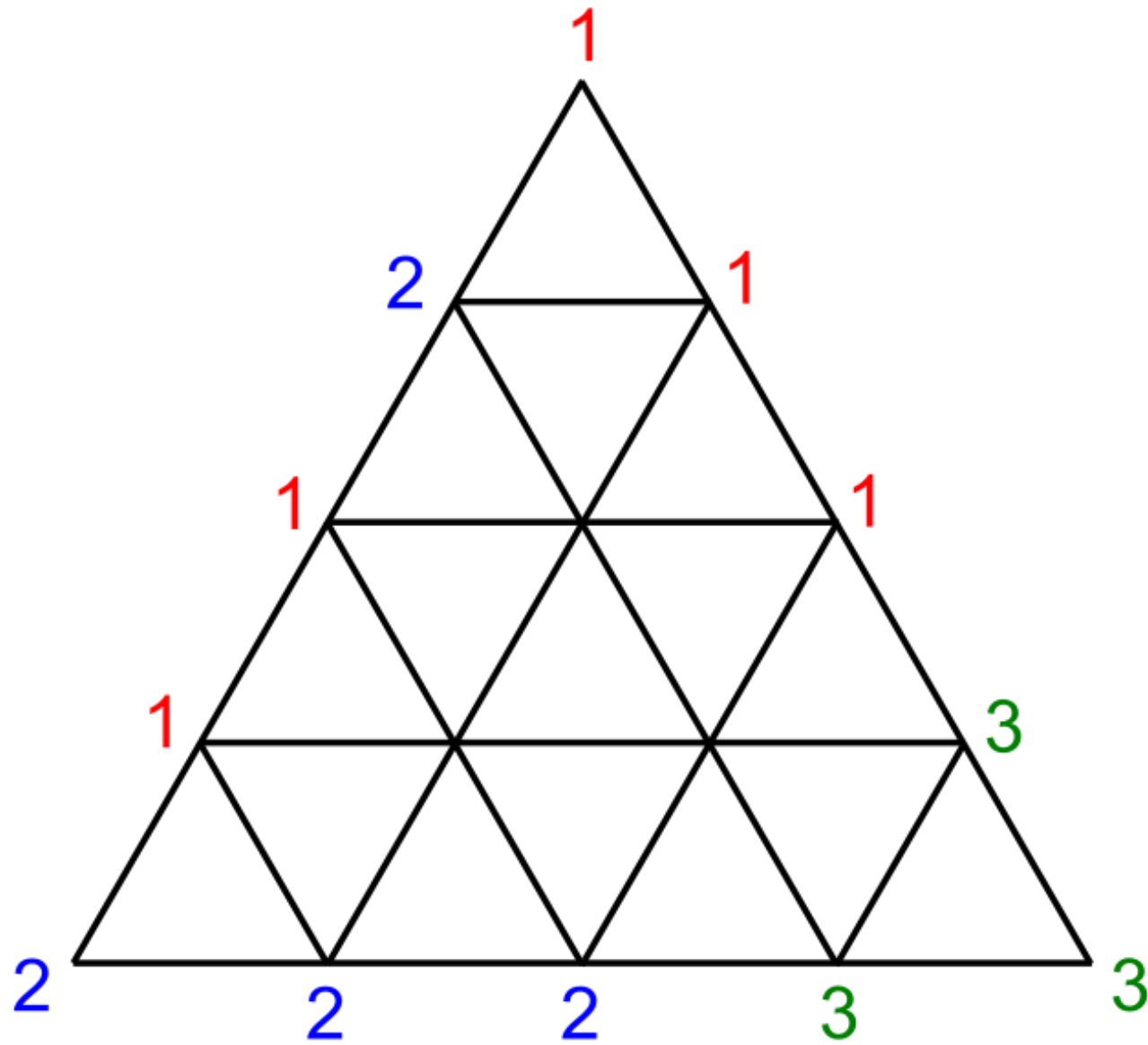

1. Triangulation into *elementary* triangles
2. Sperner labeling
 - Main vertices have distinct labels
 - Boundary vertices inherit the labels of the adjacent main vertices

Sperner's Lemma

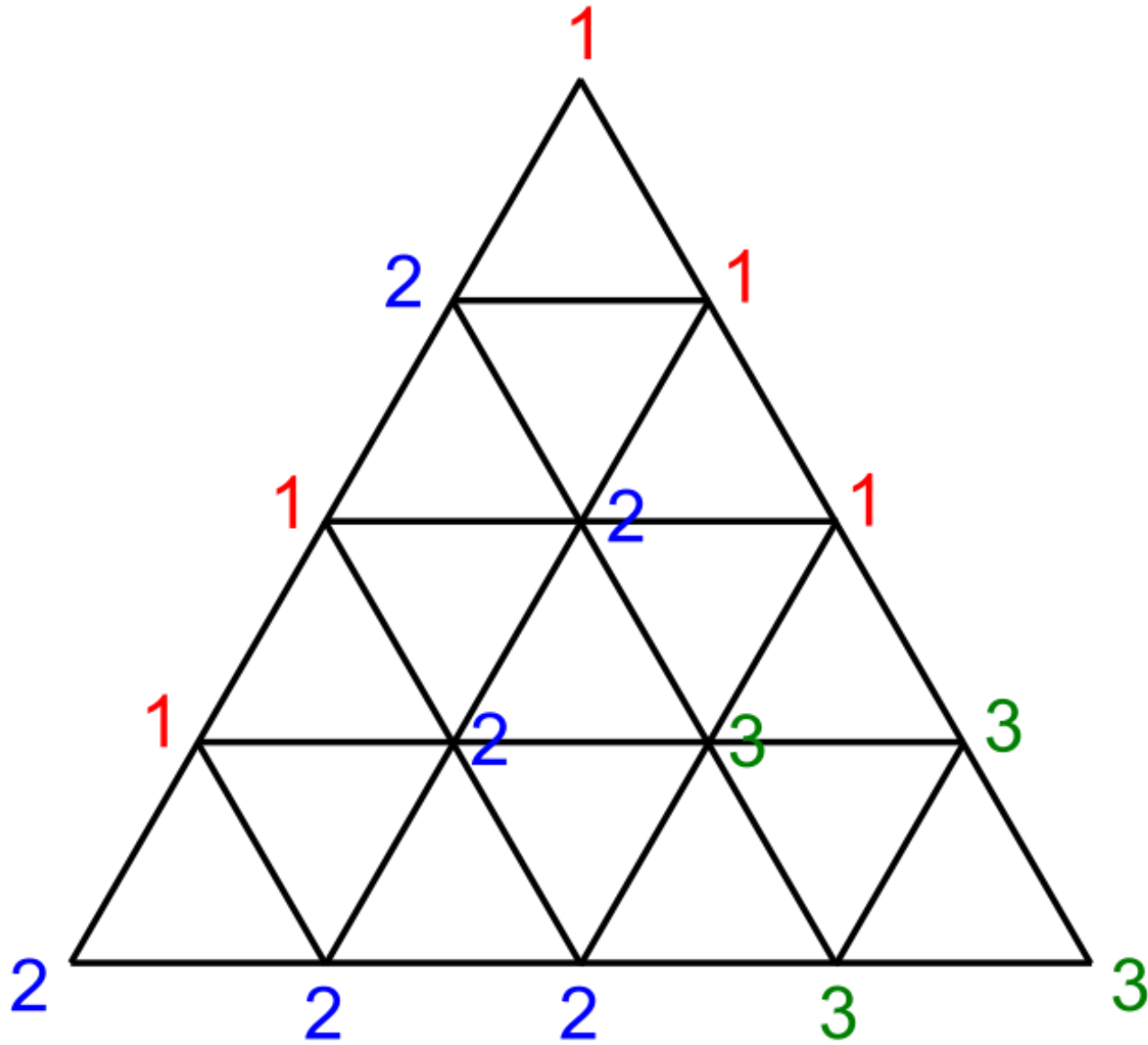

1. Triangulation into *elementary* triangles

2. Sperner labeling

- Main vertices have distinct labels
- Boundary vertices inherit the labels of the adjacent main vertices

Sperner's Lemma

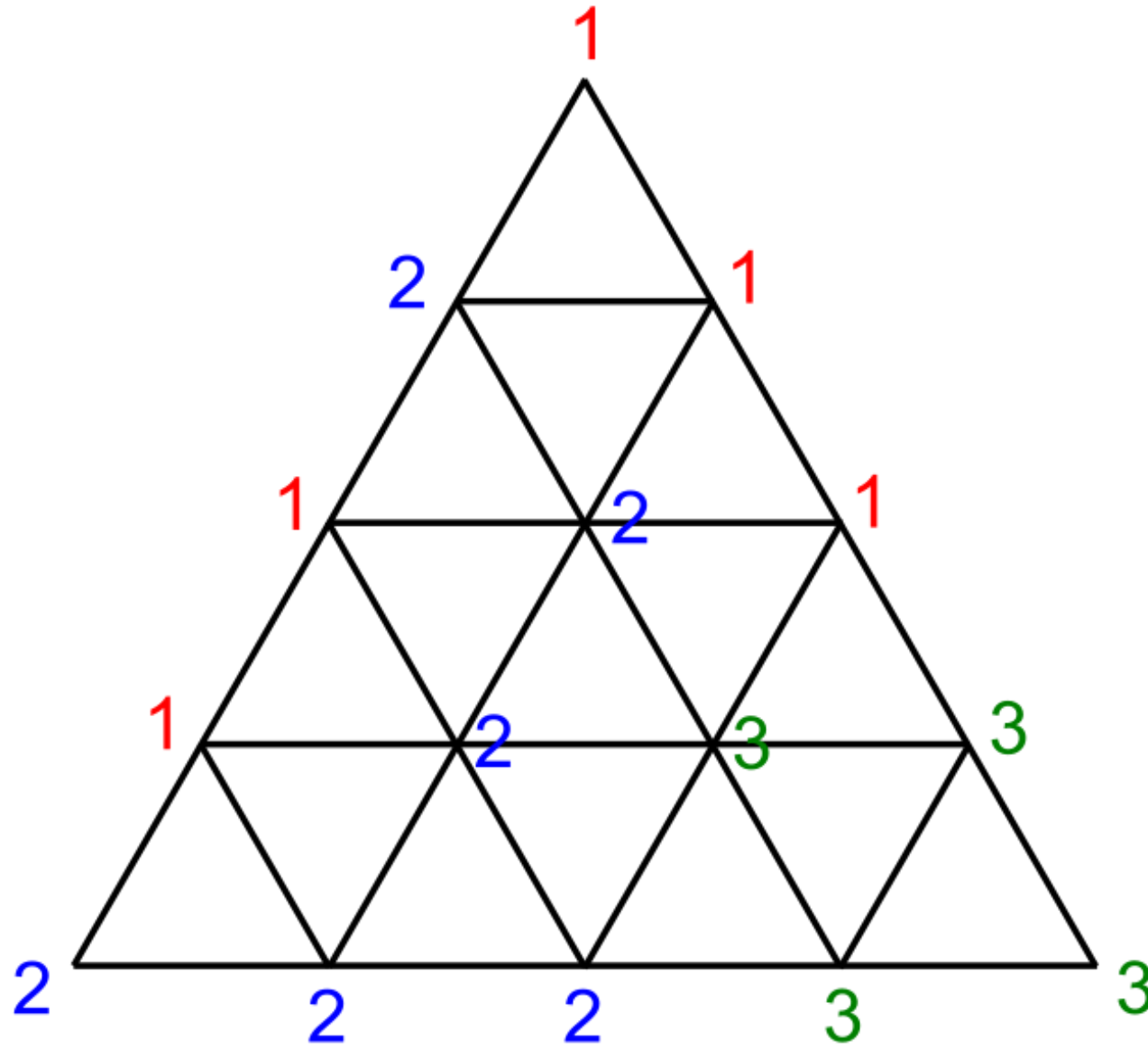

1. Triangulation into *elementary* triangles

2. Sperner labeling

- Main vertices have distinct labels
- Boundary vertices inherit the labels of the adjacent main vertices

[Sperner, 1928]

Any Sperner labeled triangulation has at least one fully labeled elementary triangle.

Sperner's Lemma

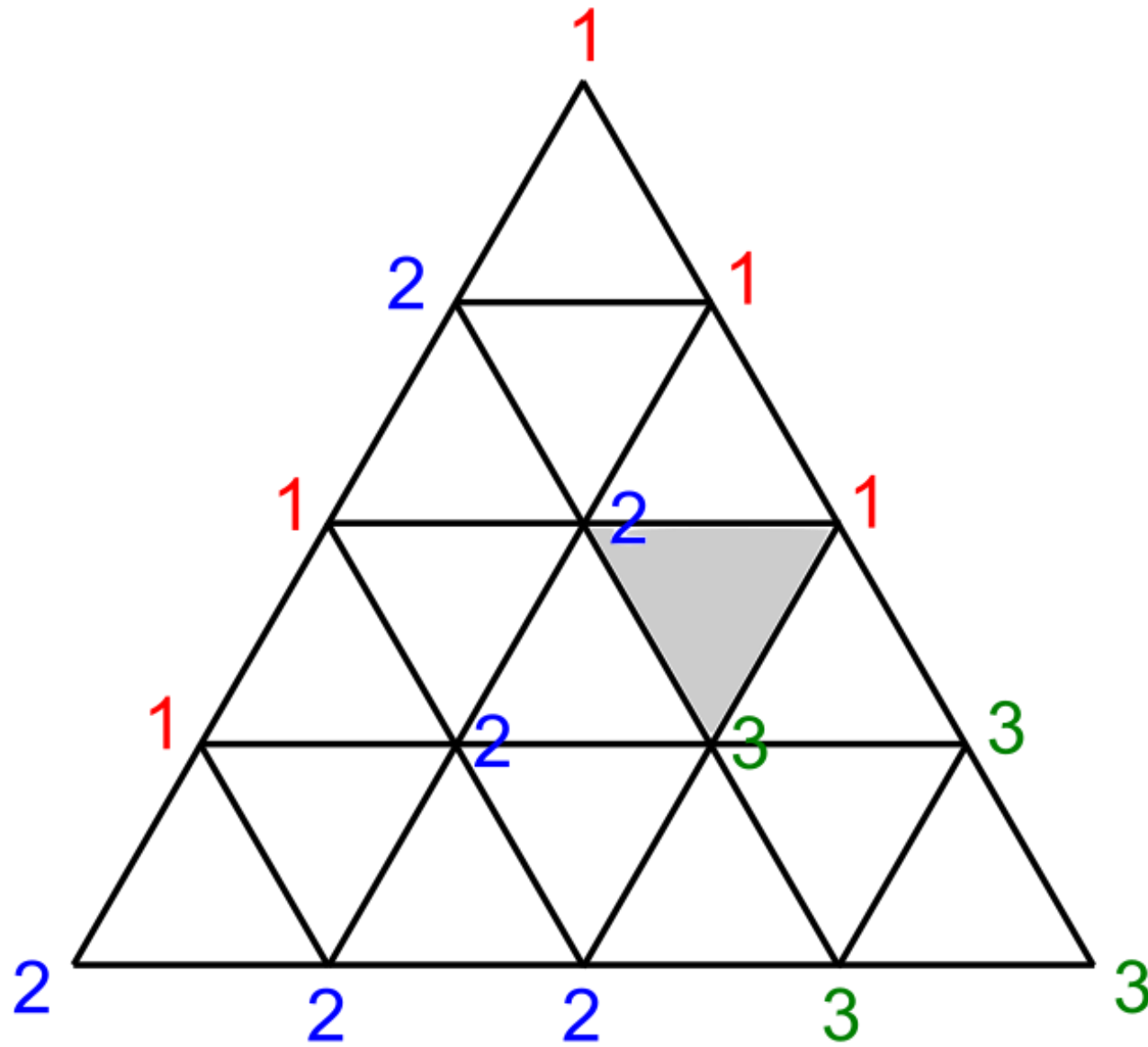

1. Triangulation into *elementary* triangles

2. Sperner labeling

- Main vertices have distinct labels
- Boundary vertices inherit the labels of the adjacent main vertices

[Sperner, 1928]

Any Sperner labeled triangulation has at least one fully labeled elementary triangle.

Triangles!

Cake Cutting

Rent Division

Cake Cutting

Rental harmony
via
Sperner's lemma

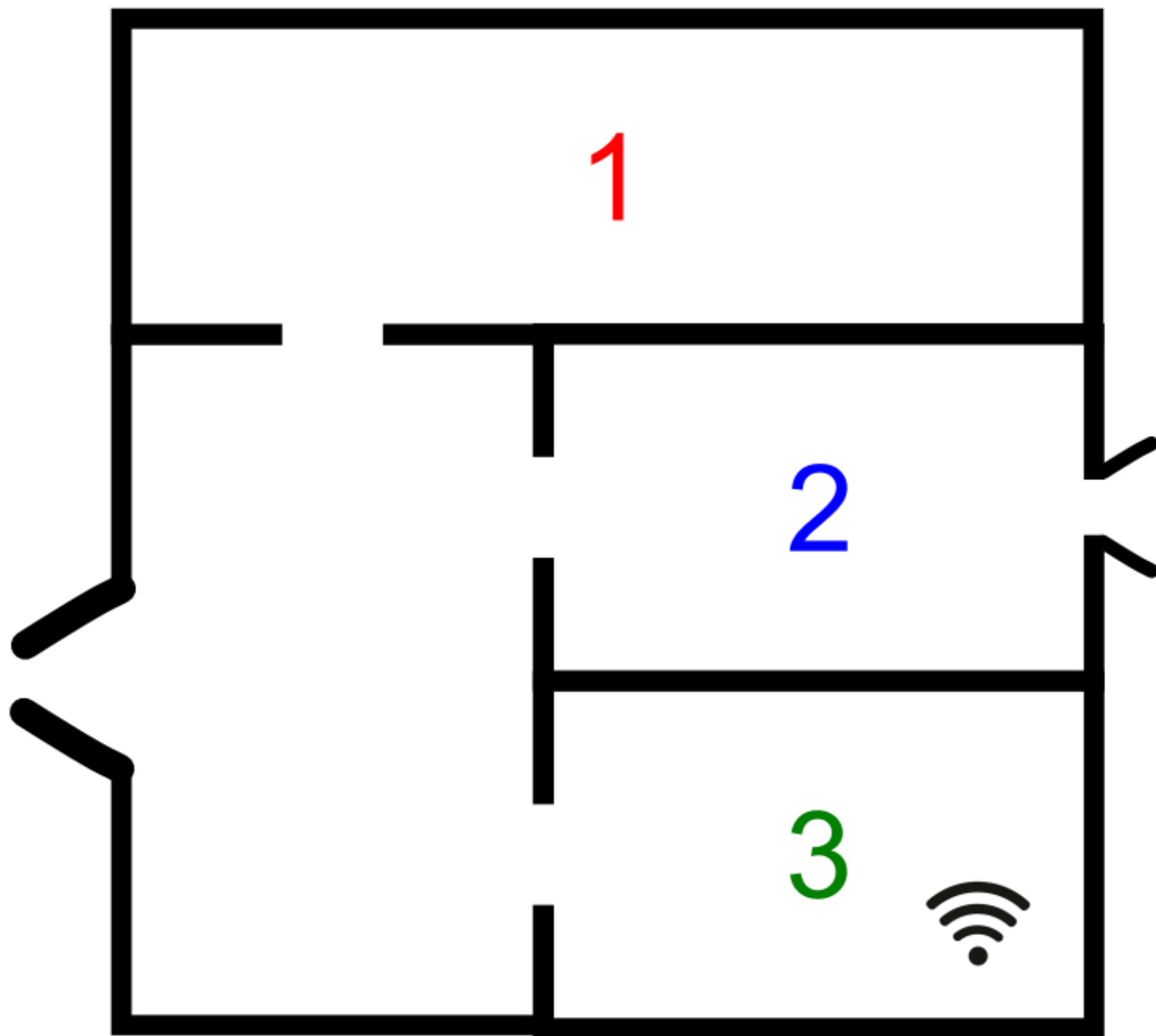

Rent
=
1000

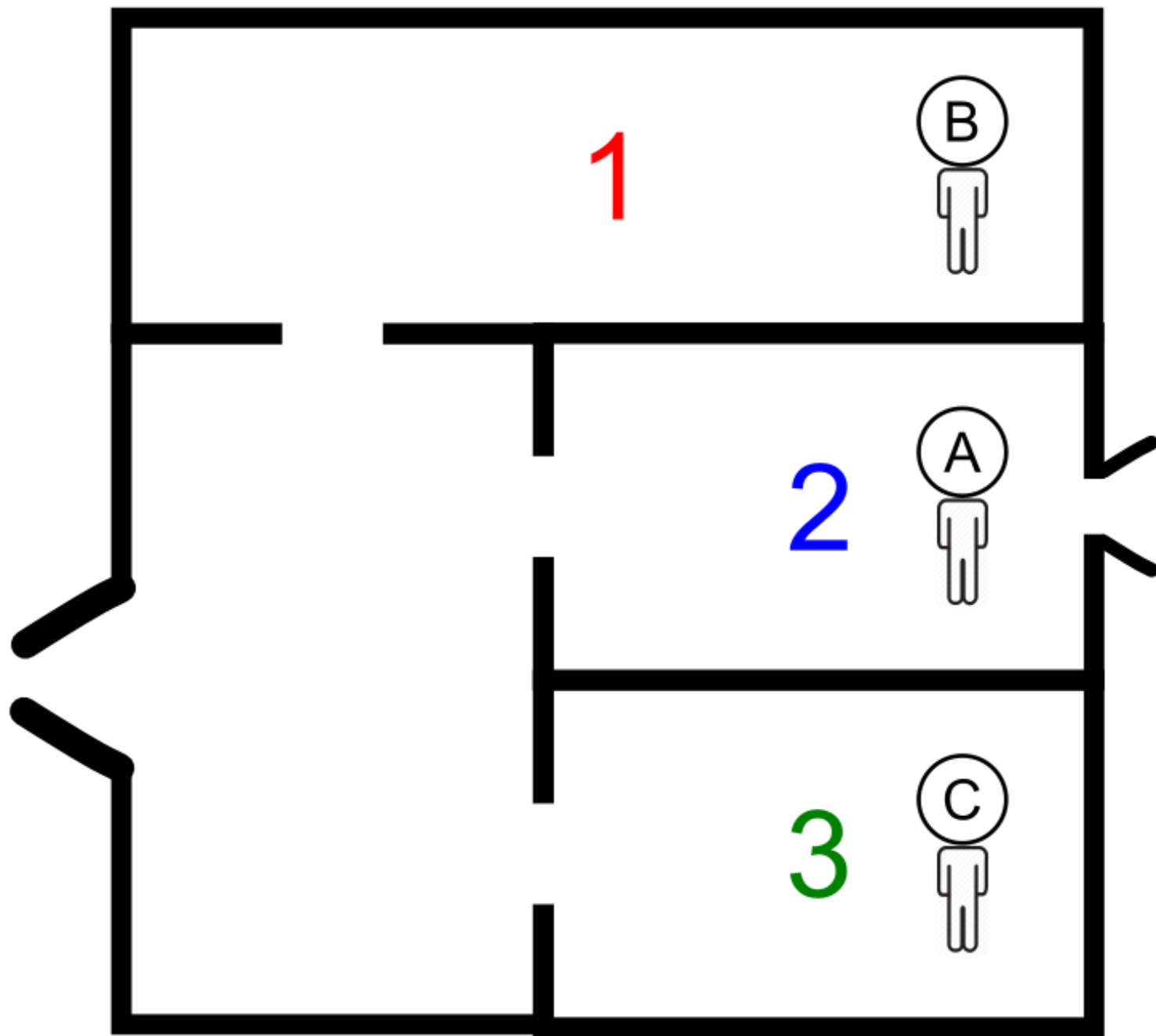

Rent
=
1000

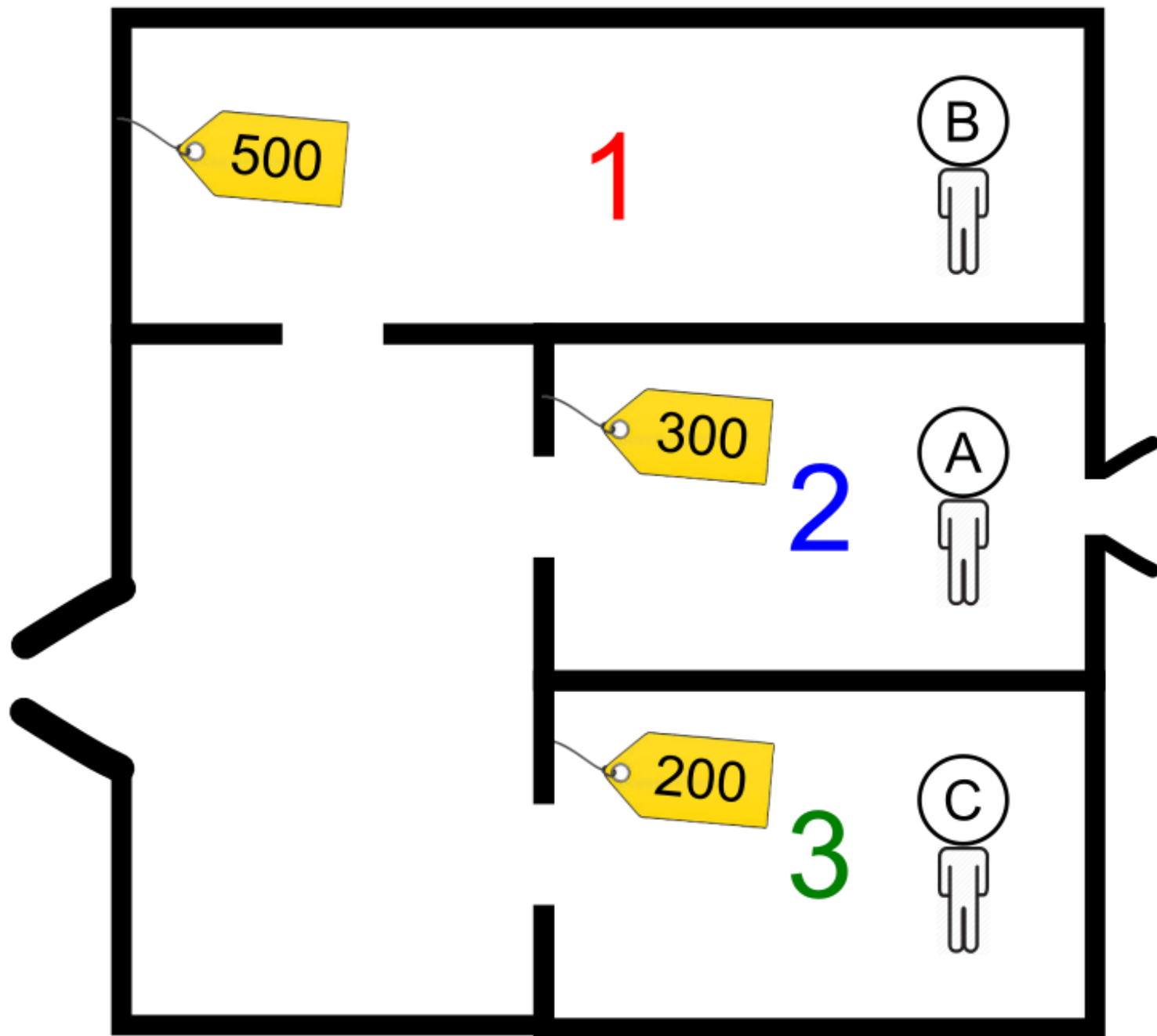

Rent
=
1000

Envy-free rent division

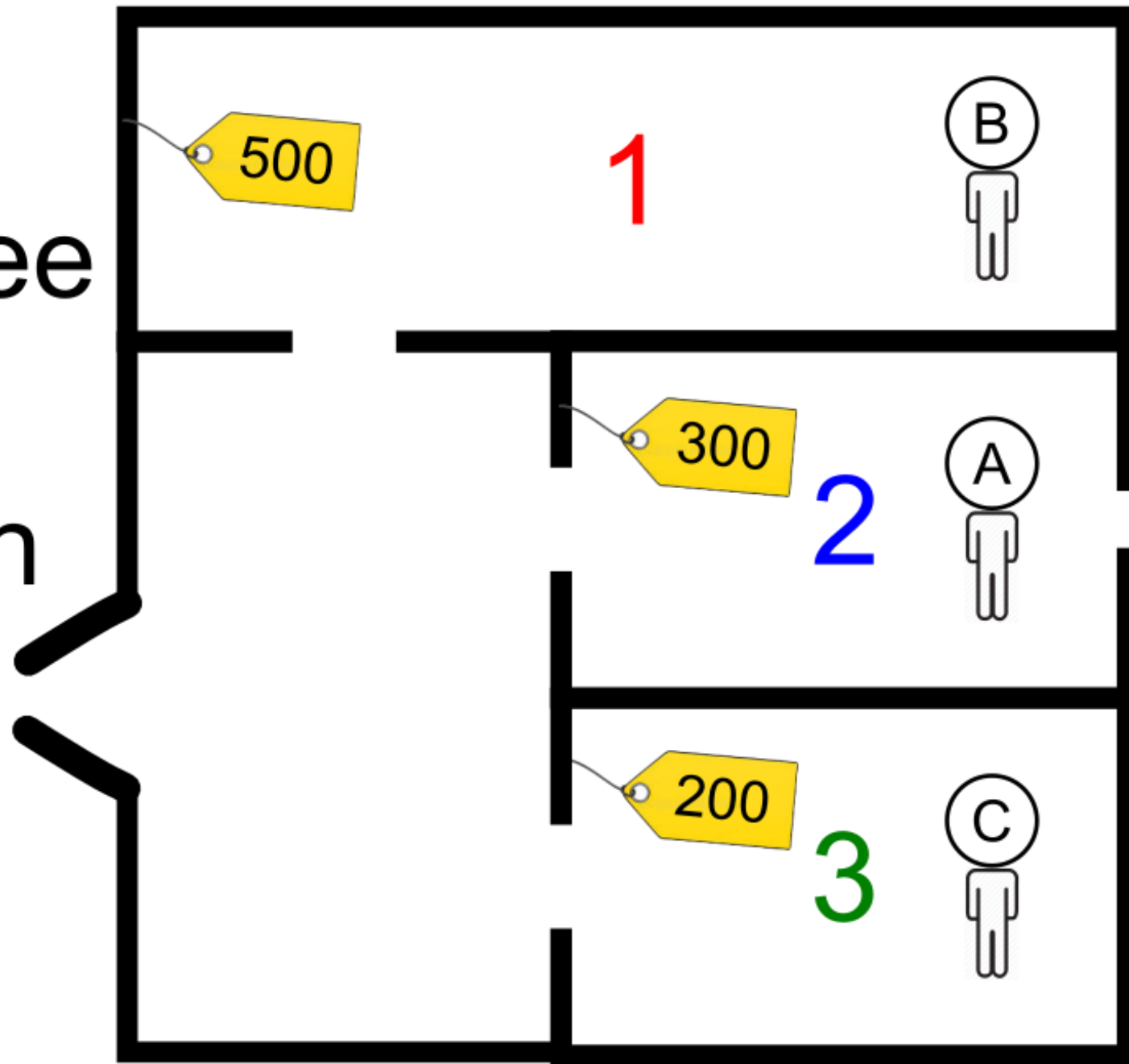

I like Room 1 for Rs. 500 over Room 2 for Rs. 300 and Room 3 for Rs. 200.

I like Room 2 for Rs. 300 over Room 1 for Rs. 500 and Room 3 for Rs. 200.

I like Room 3 for Rs. 200 over Room 1 for Rs. 500 and Room 2 for Rs. 300.

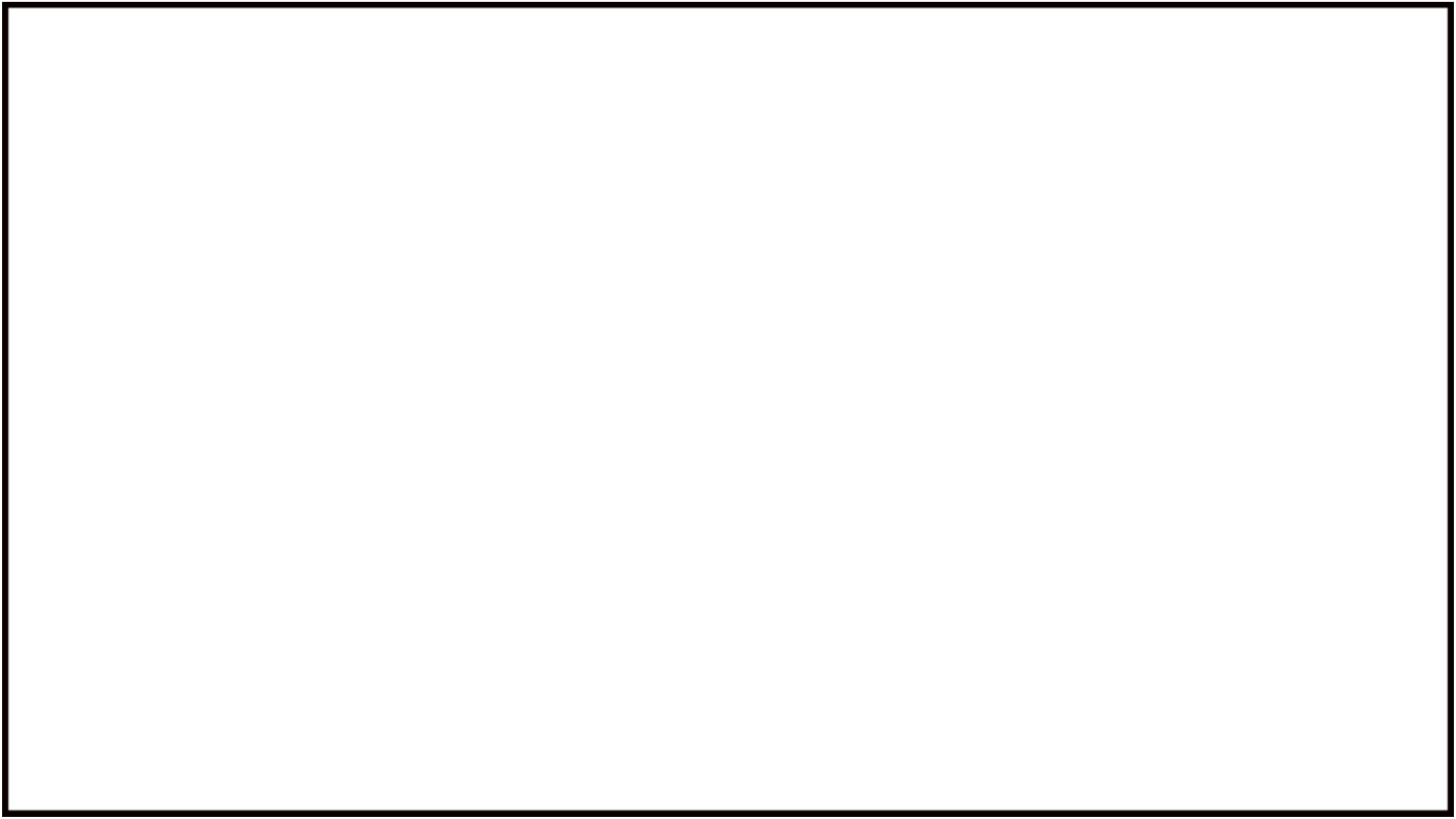

Ownership labeling

Preference labeling

Ownership labeling

Preference labeling

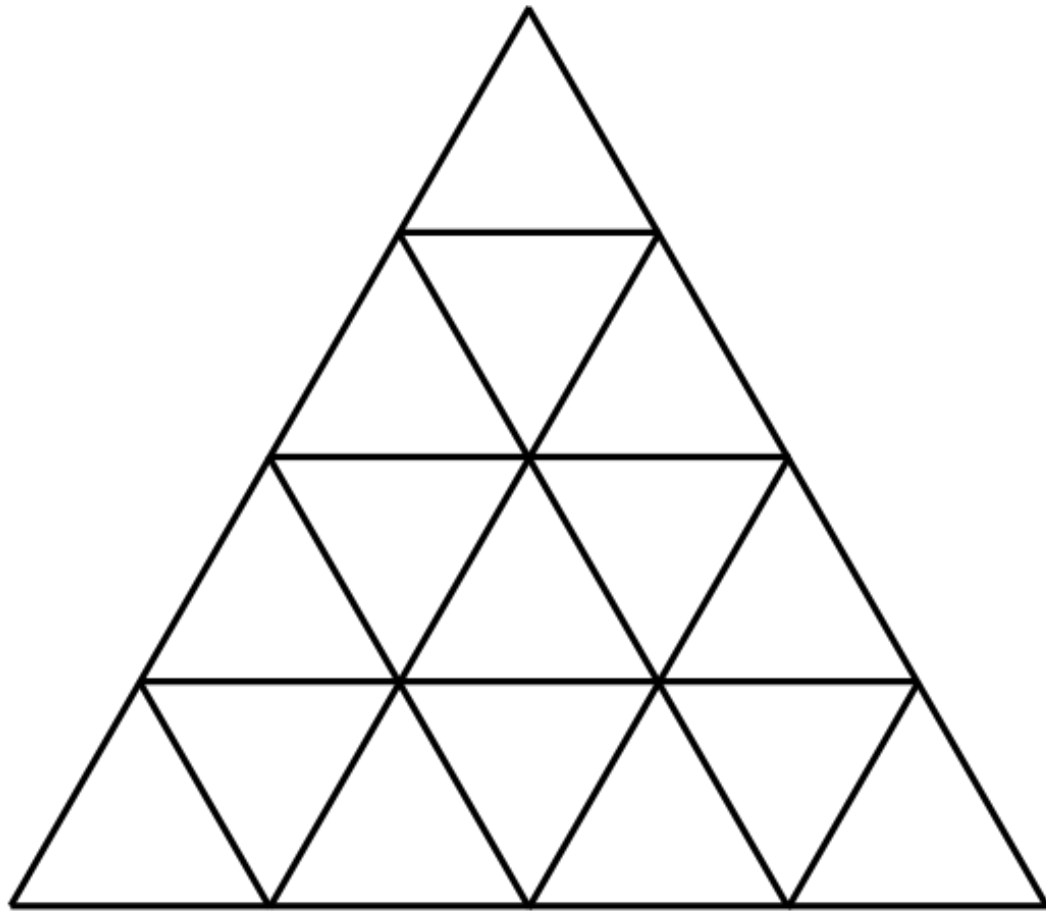

Ownership labeling

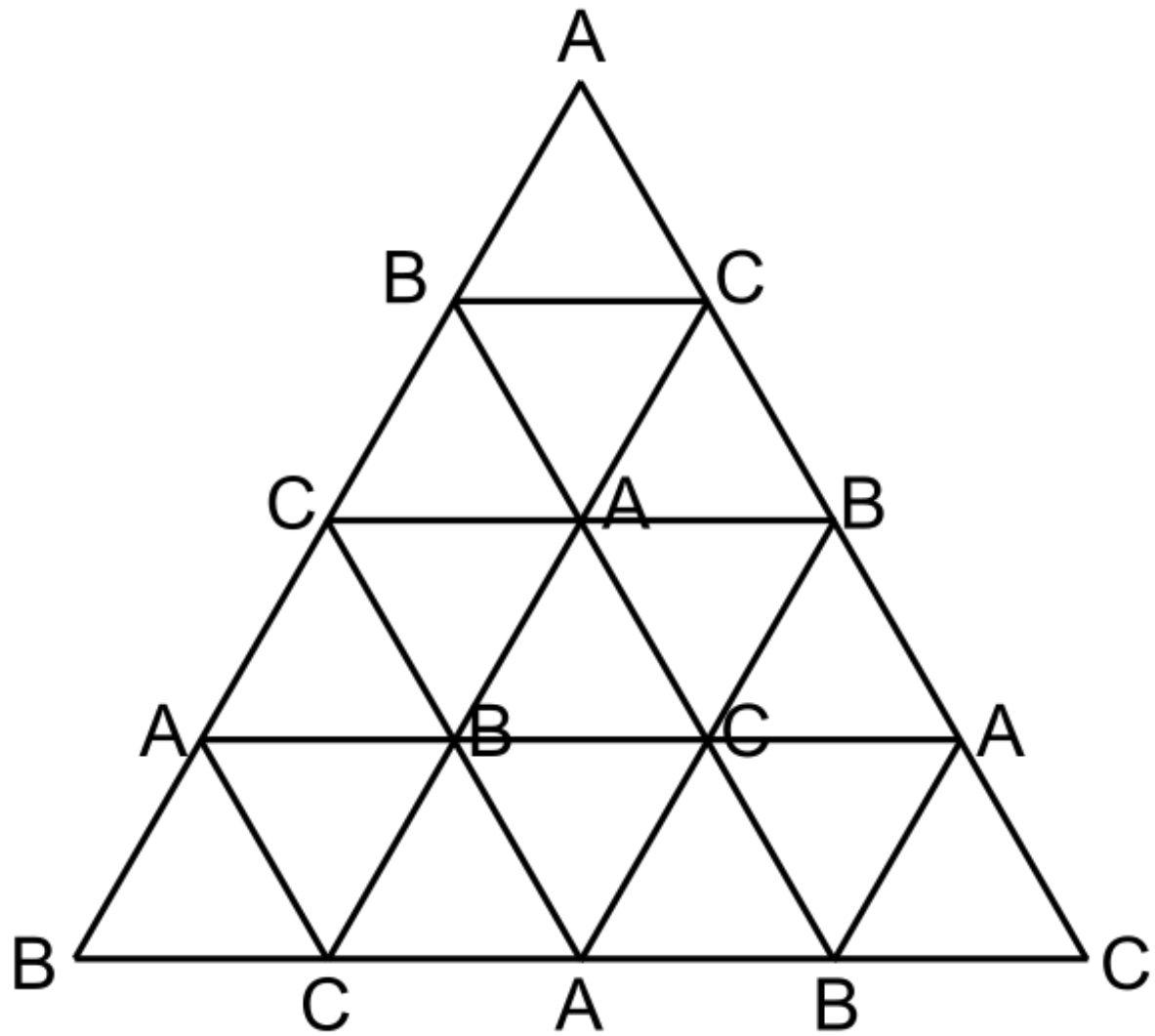

Preference labeling

Ownership labeling

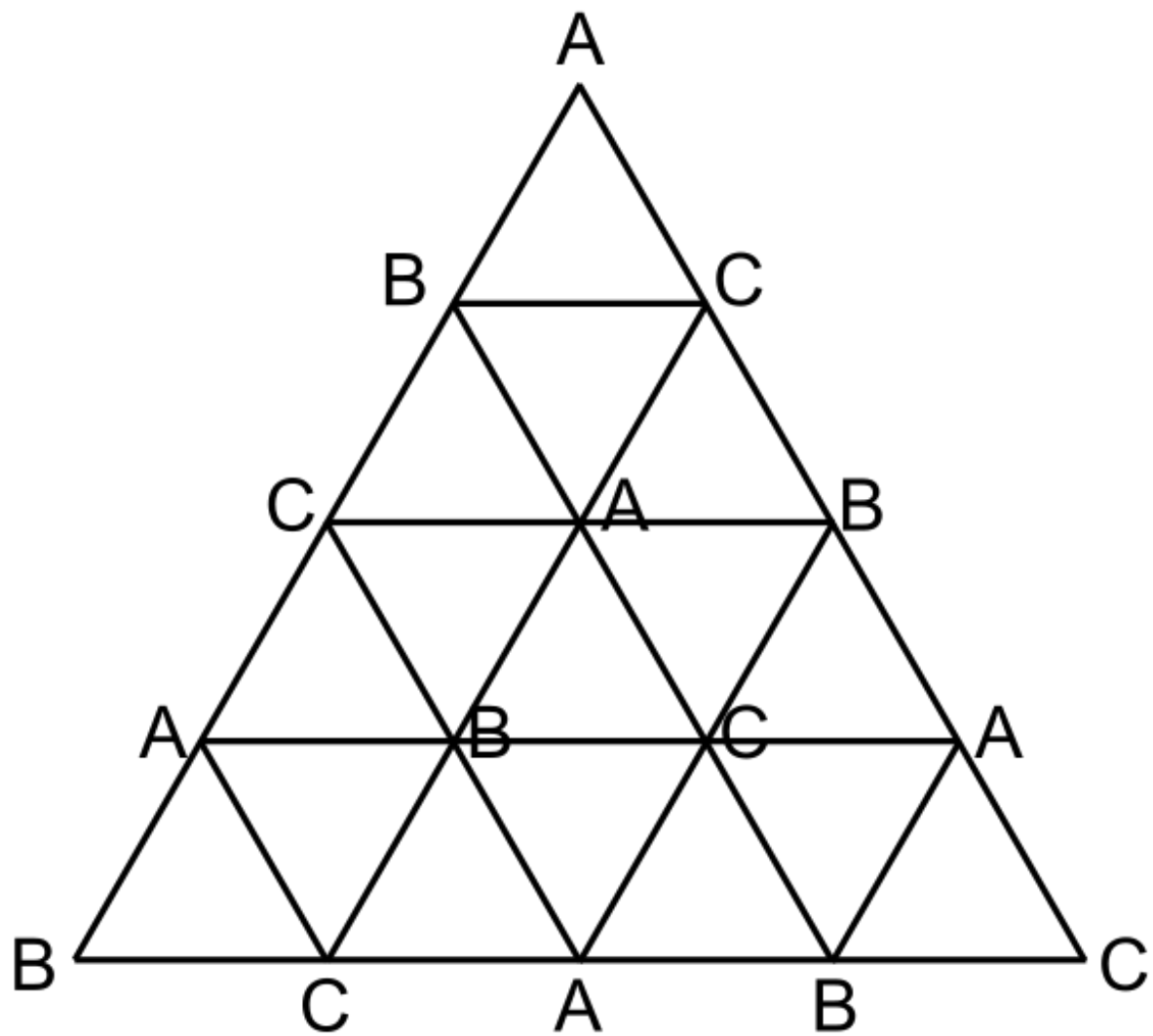

Preference labeling

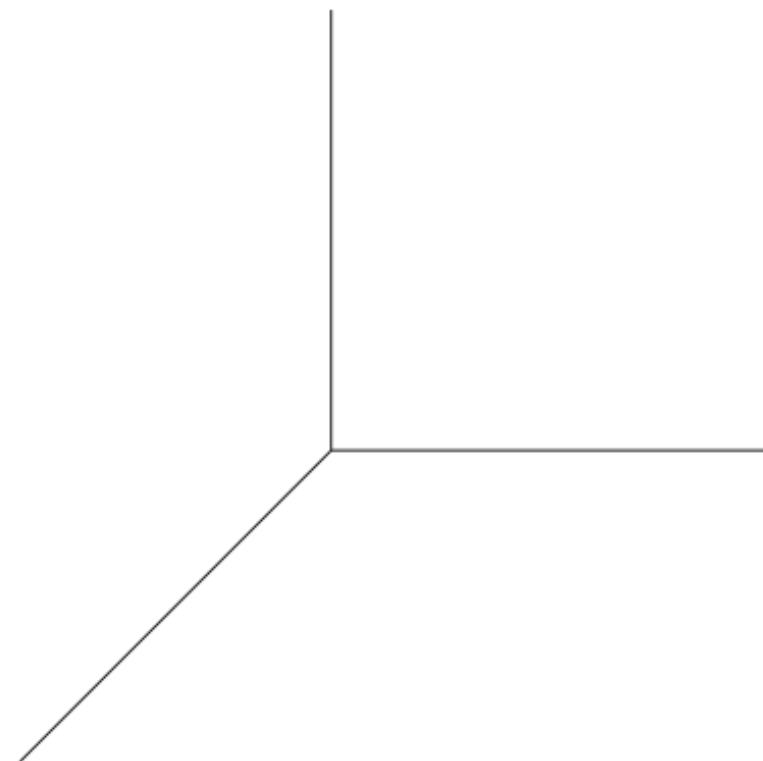

Ownership labeling

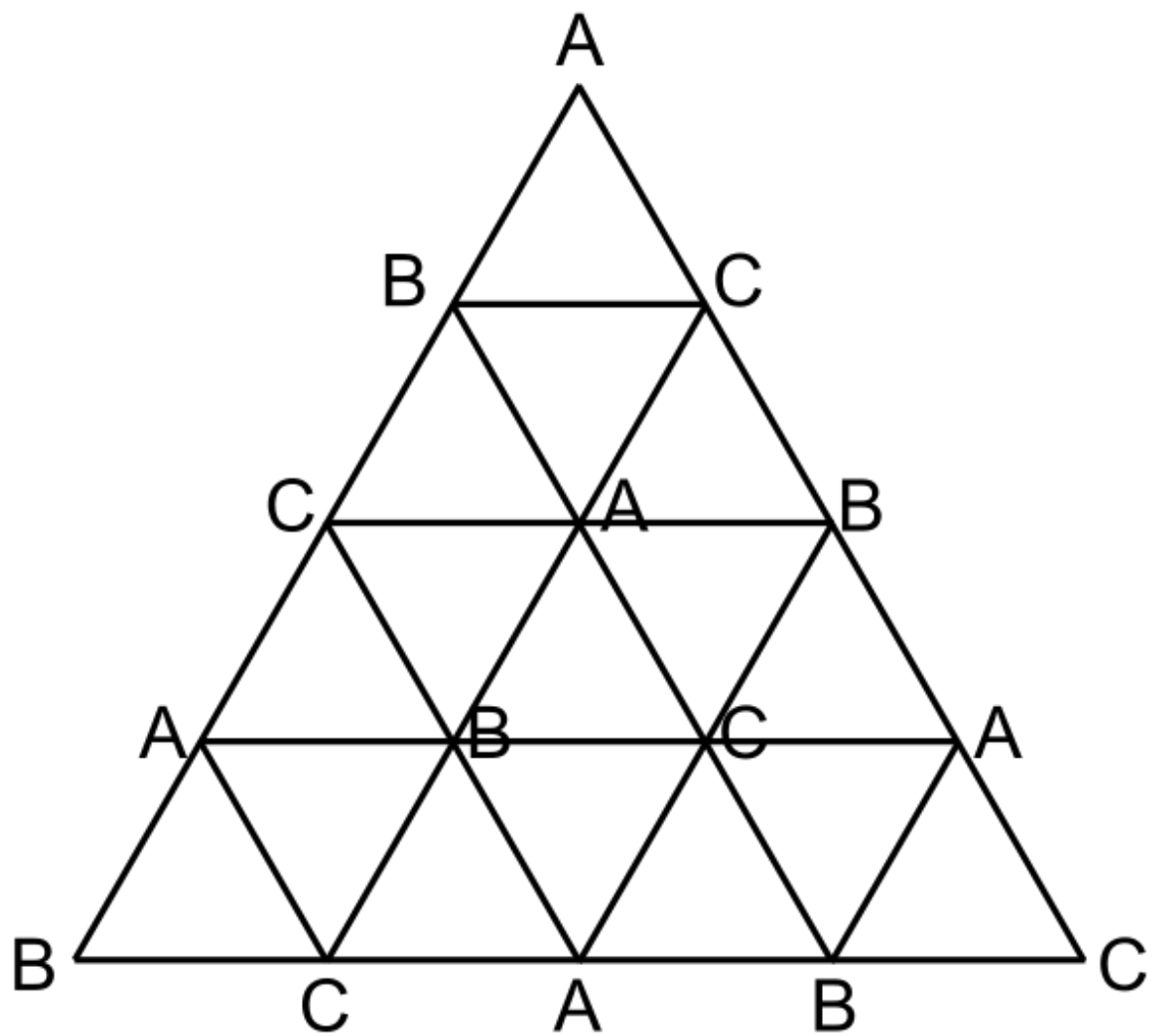

Preference labeling

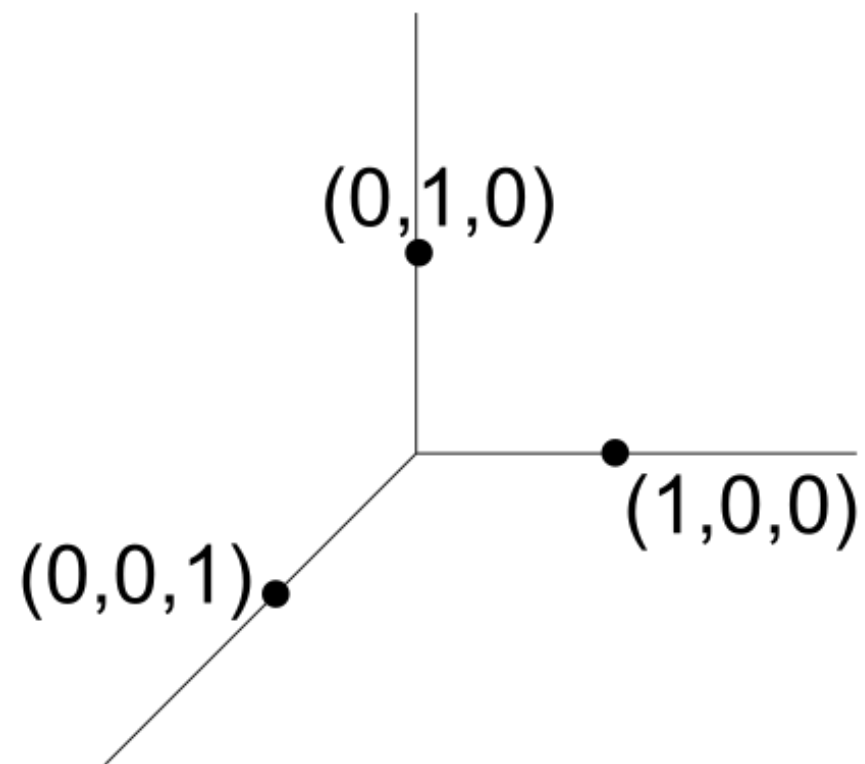

Ownership labeling

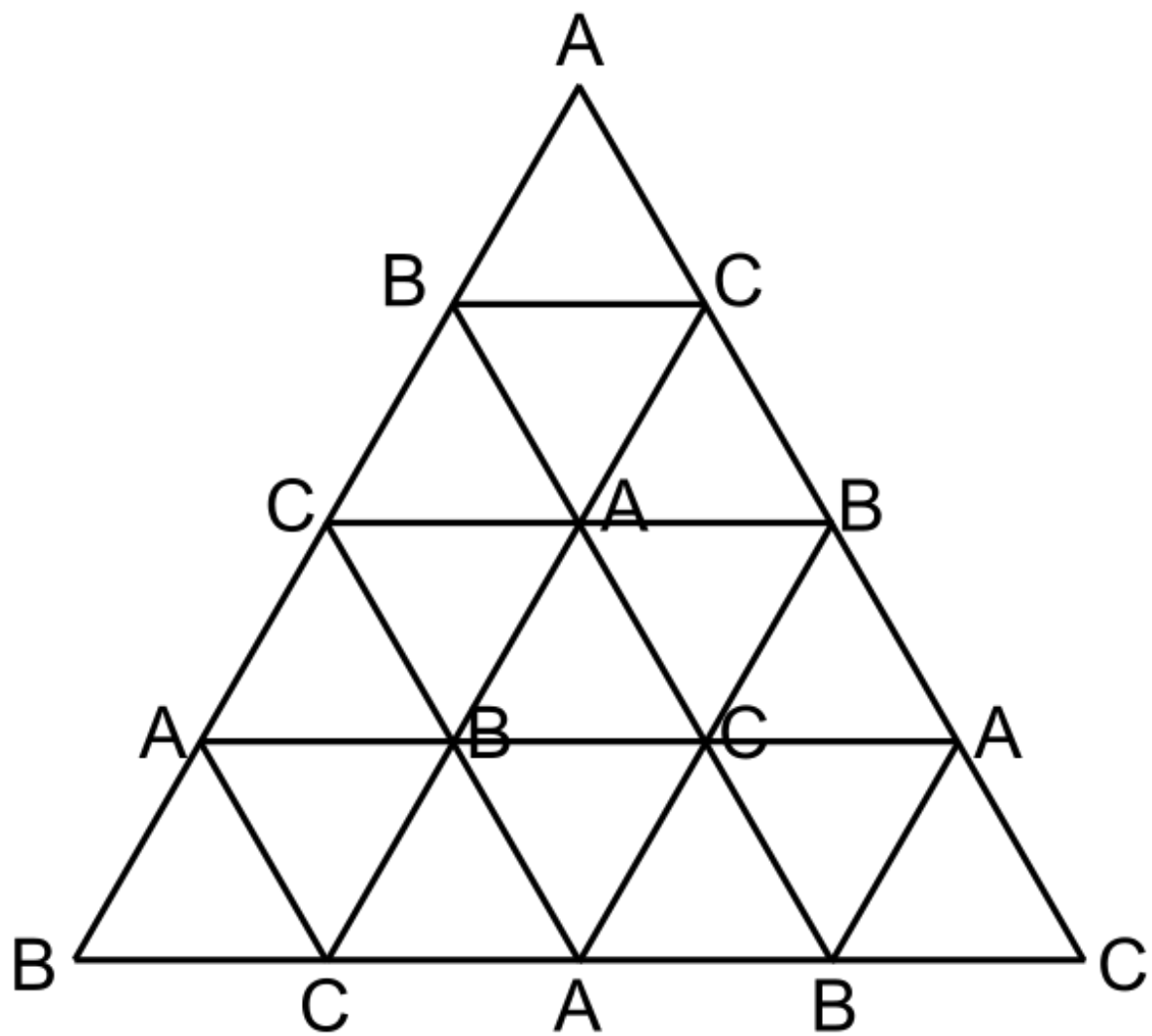

Preference labeling

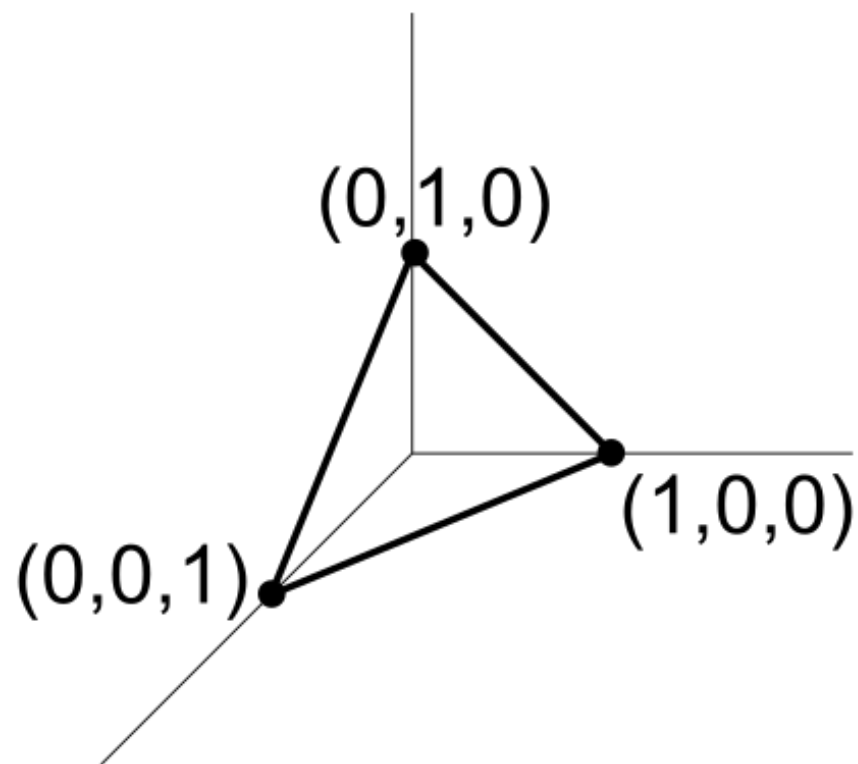

Ownership labeling

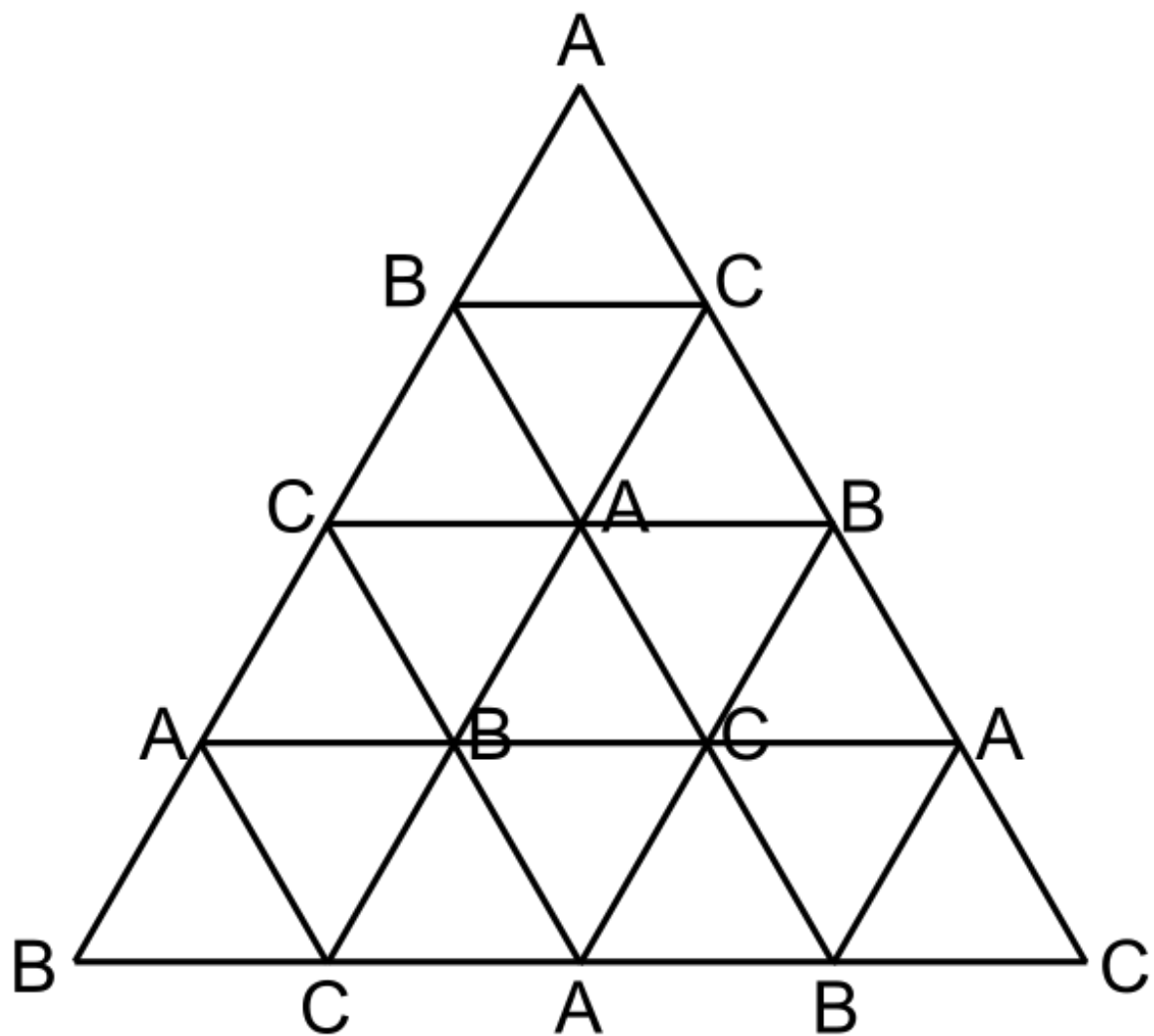

Preference labeling

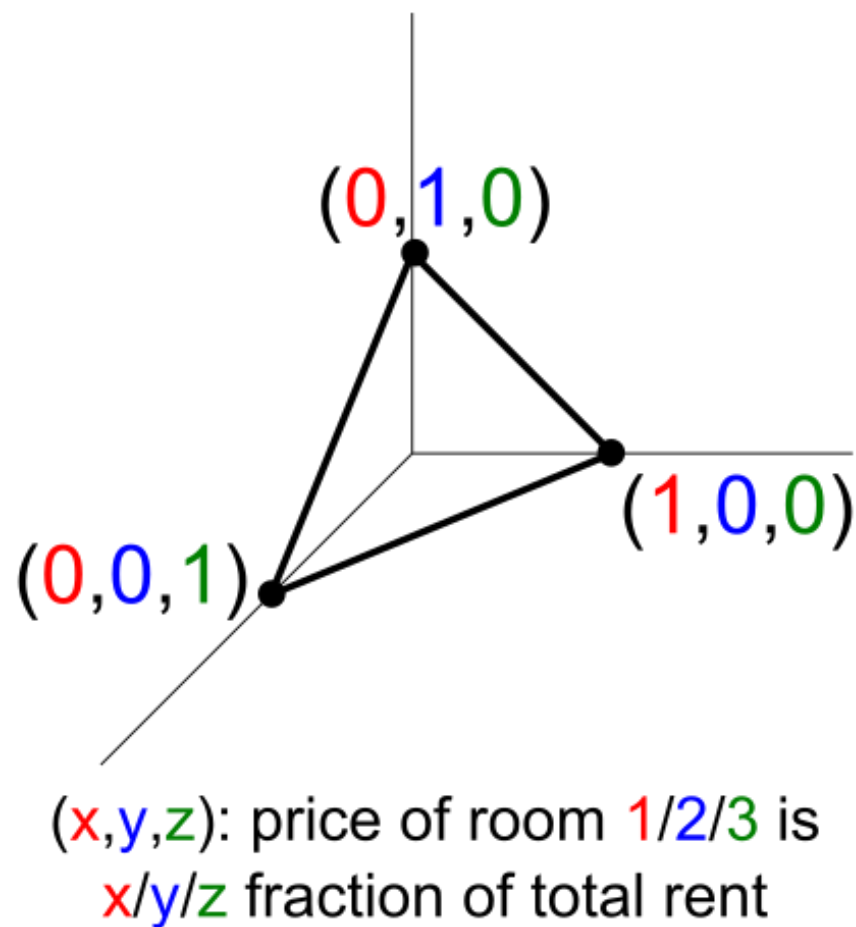

Ownership labeling

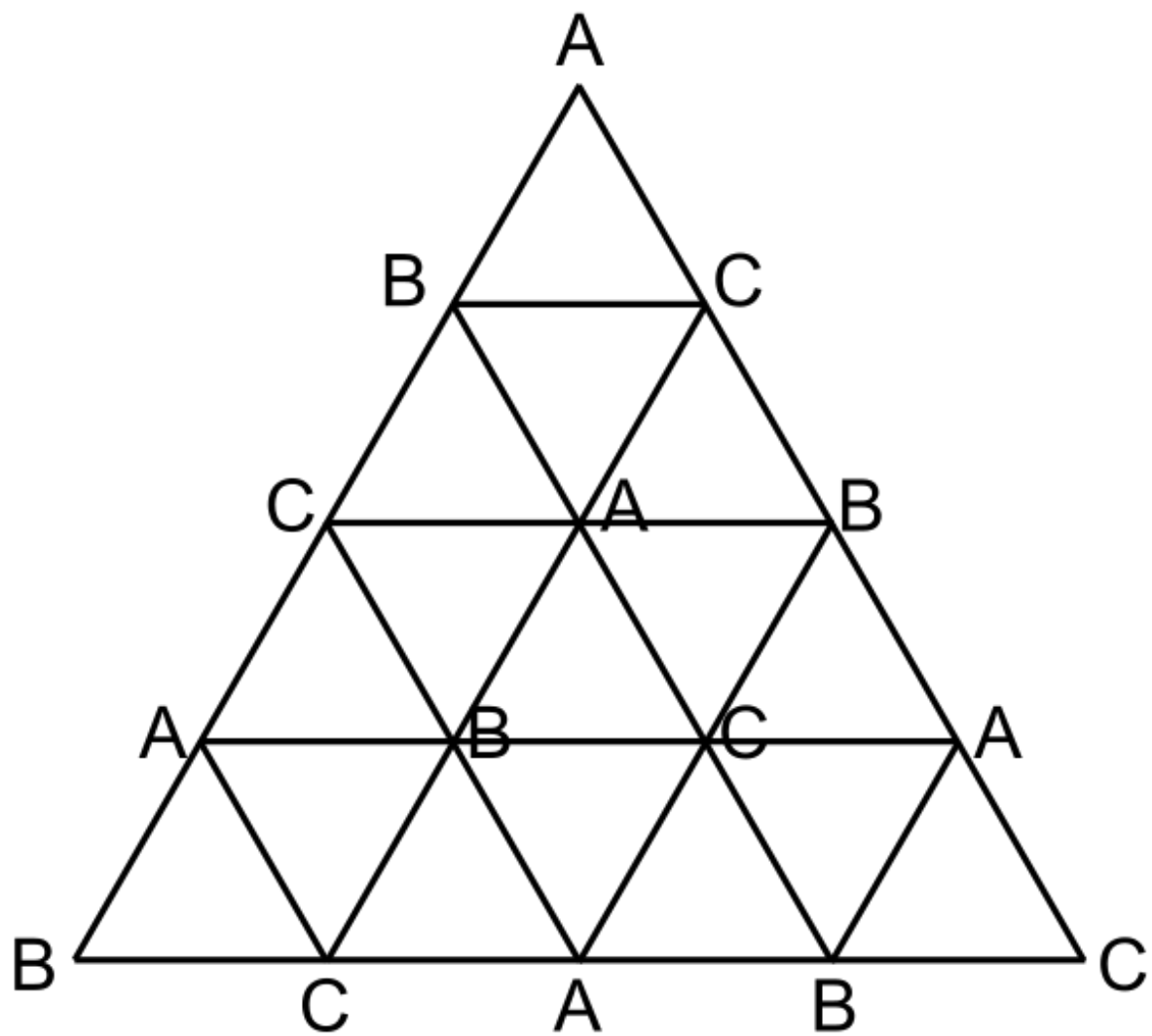

Preference labeling

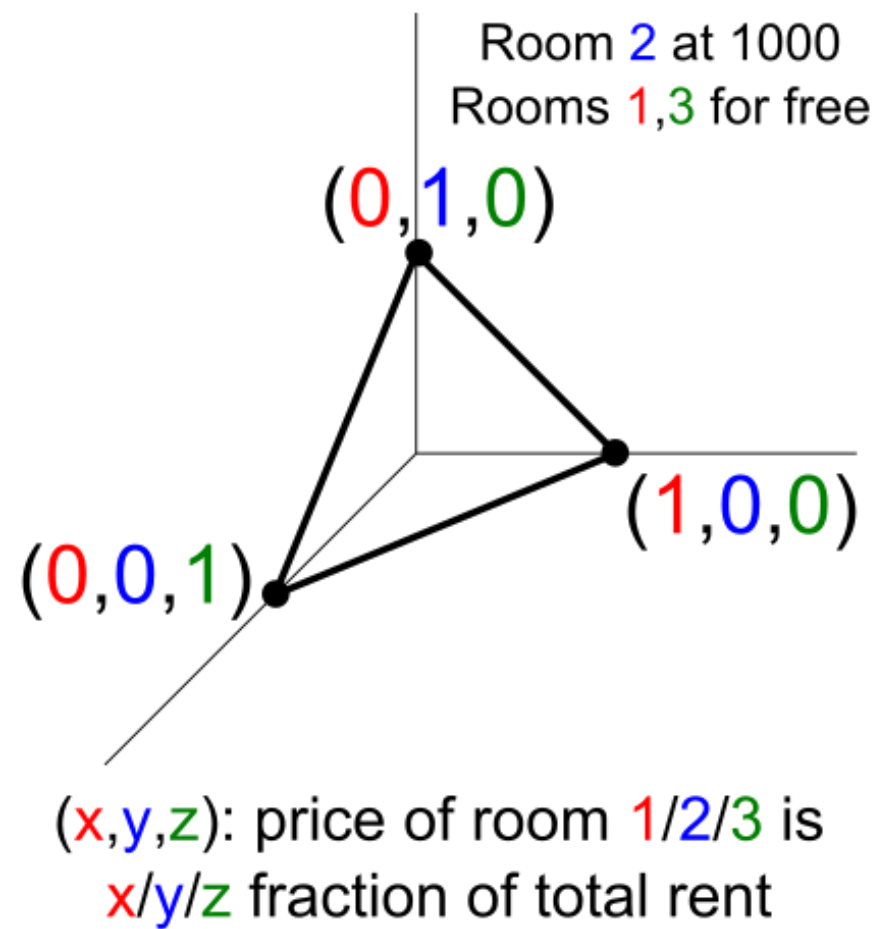

Ownership labeling

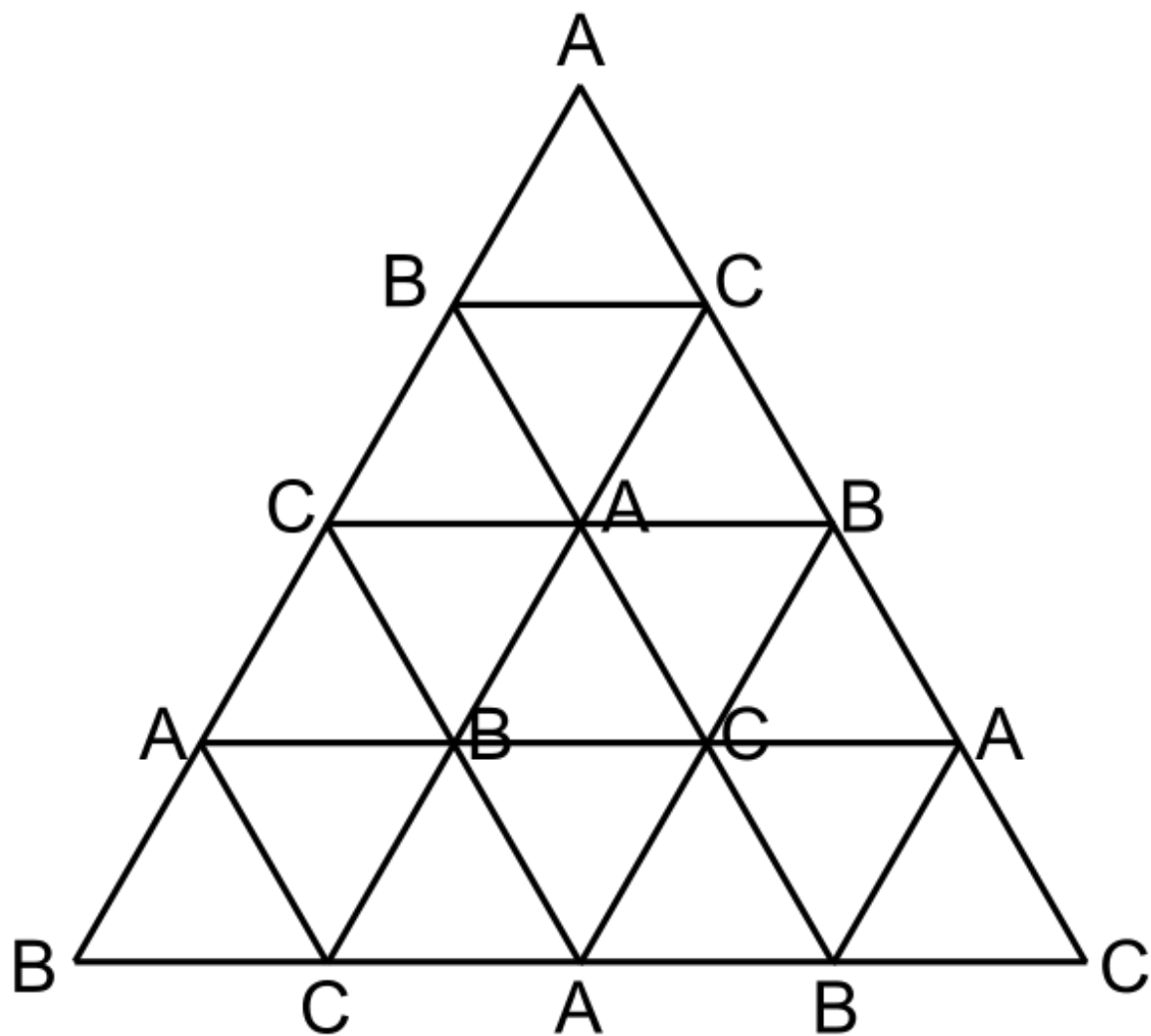

Preference labeling

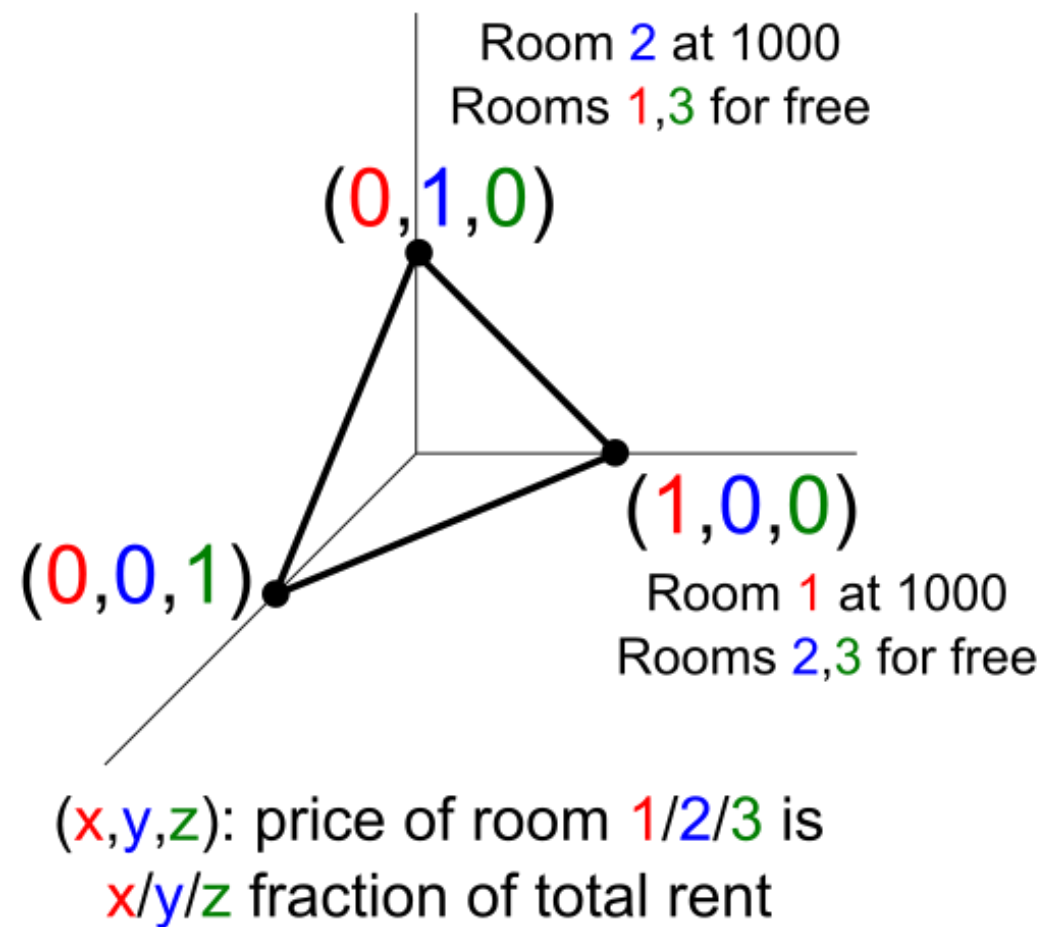

Ownership labeling

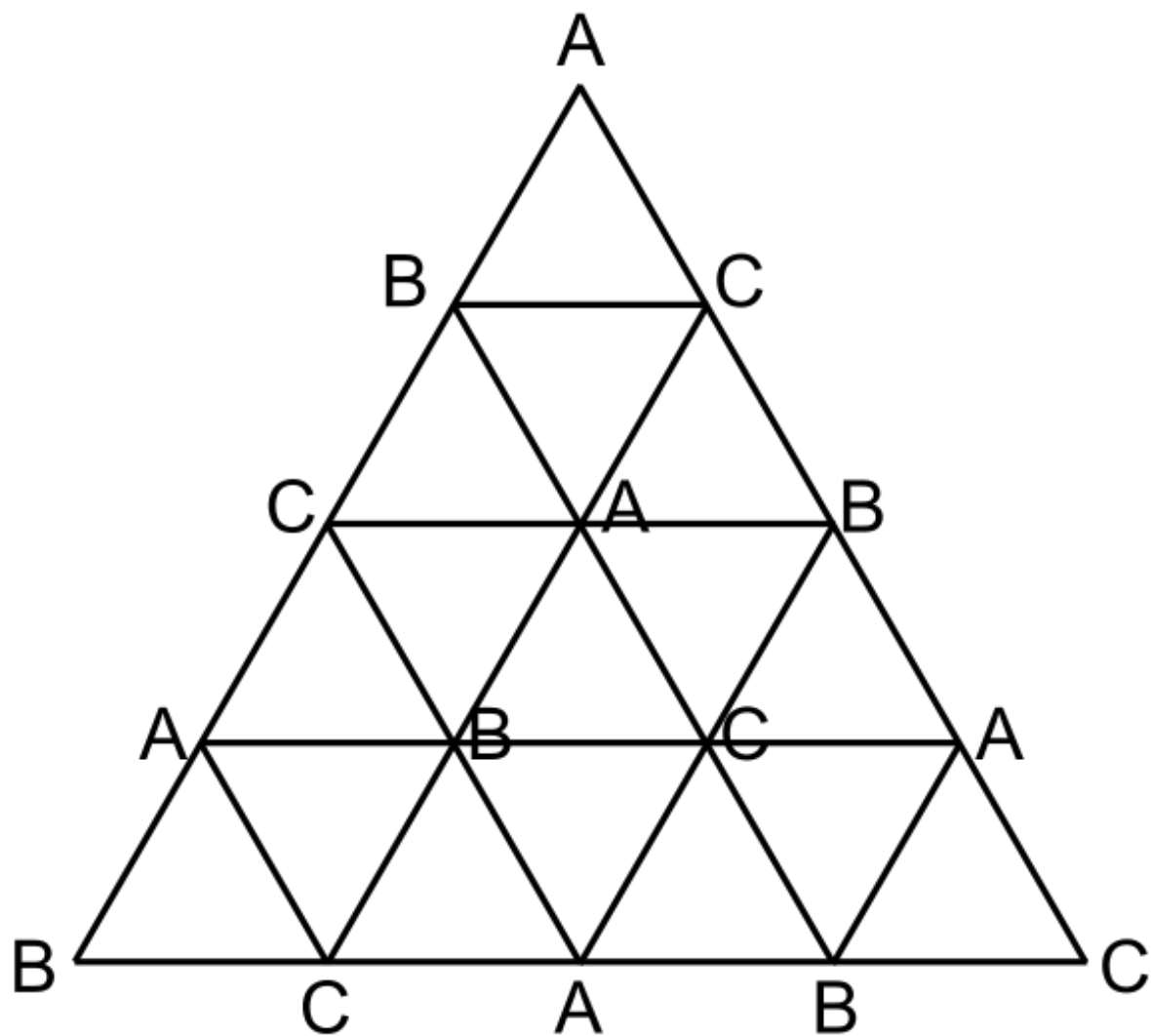

Preference labeling

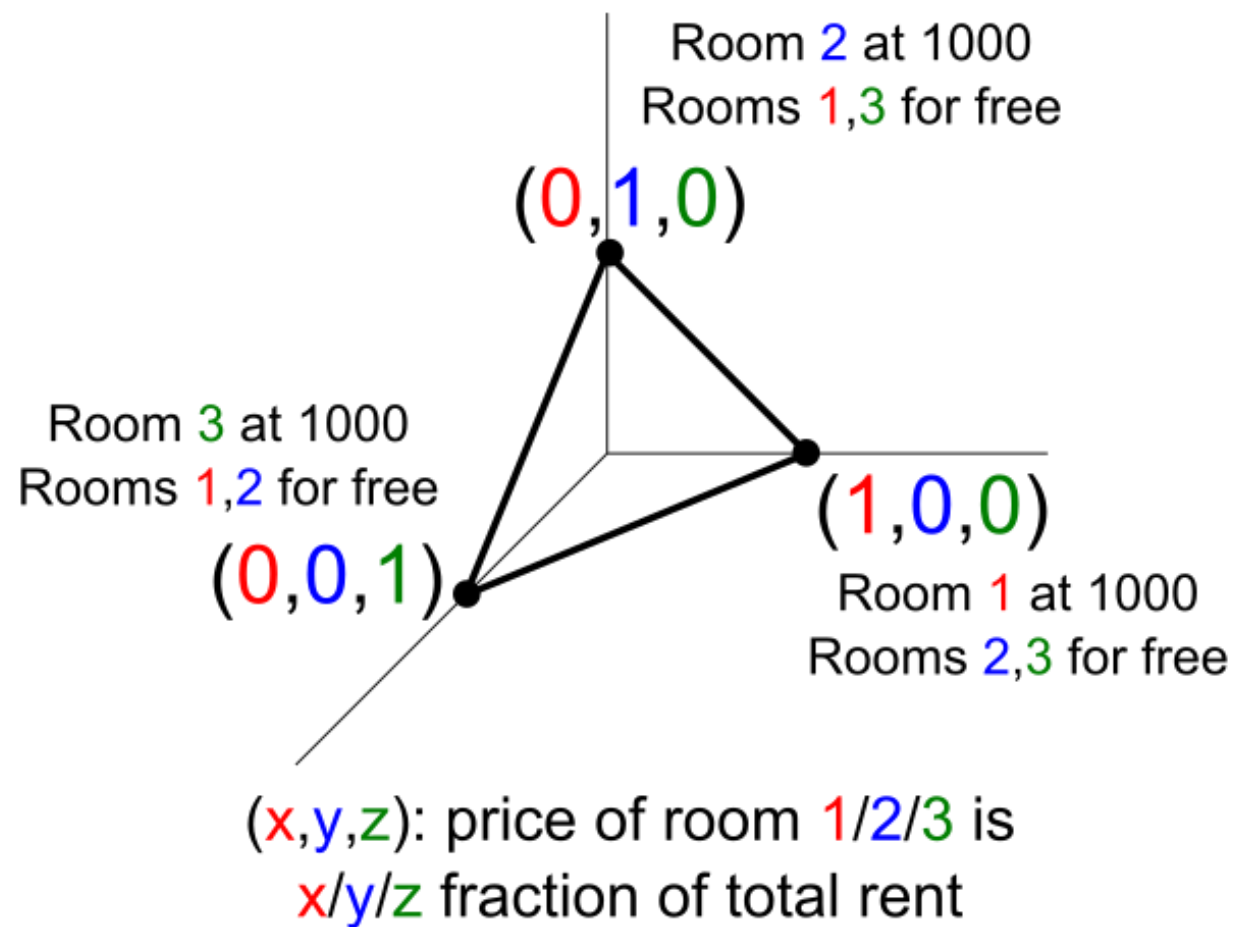

Ownership labeling

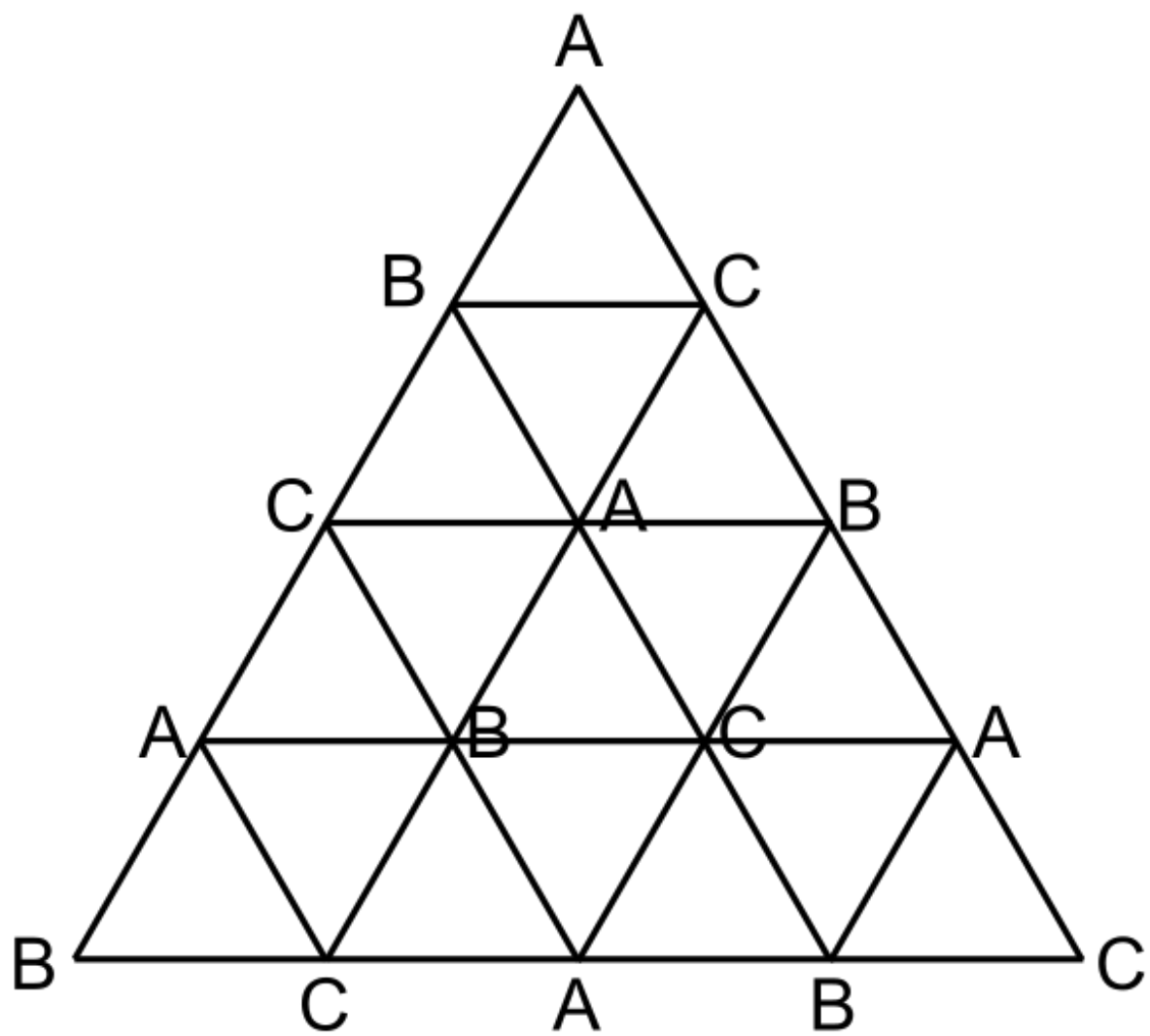

Preference labeling

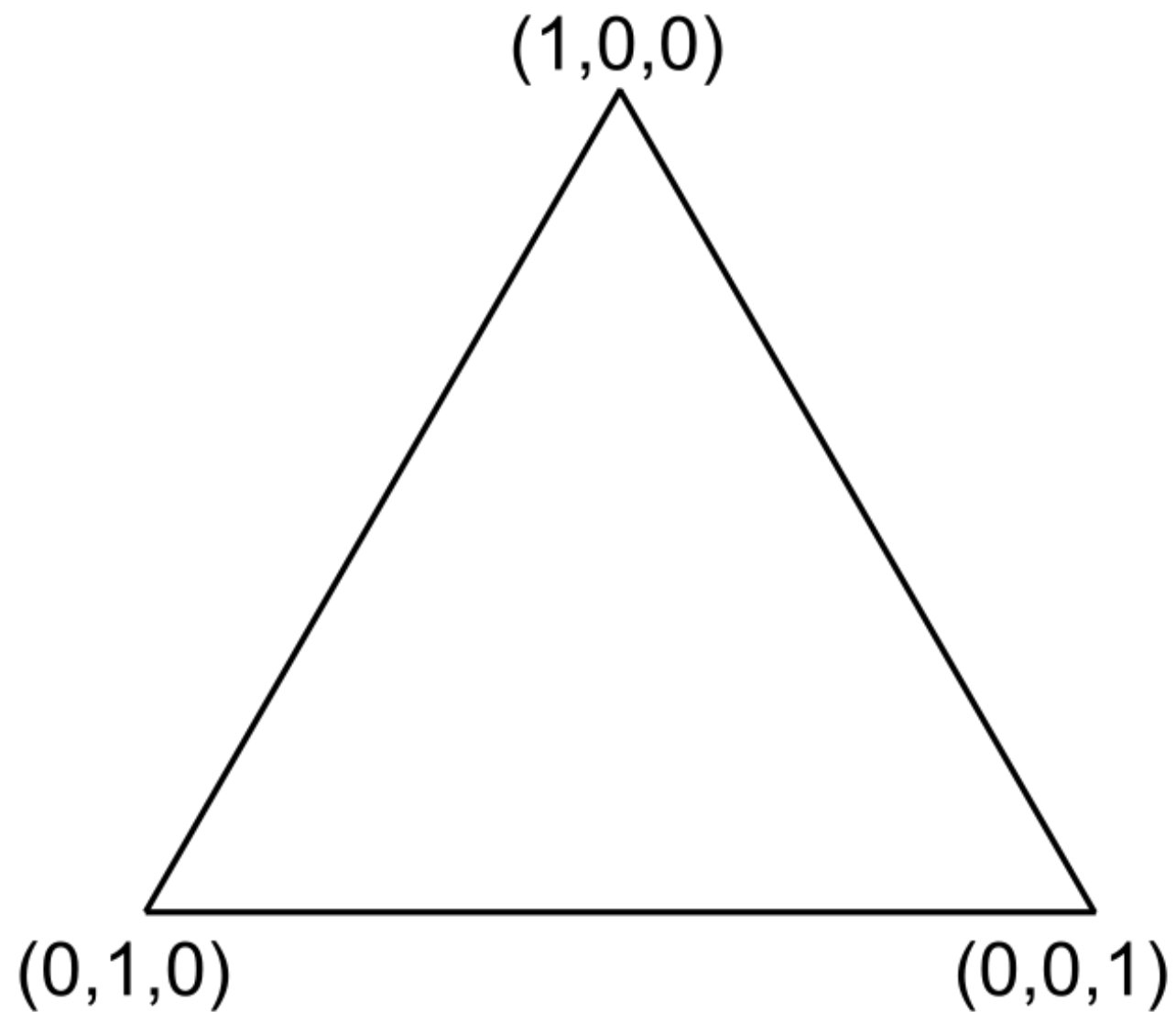

Ownership labeling

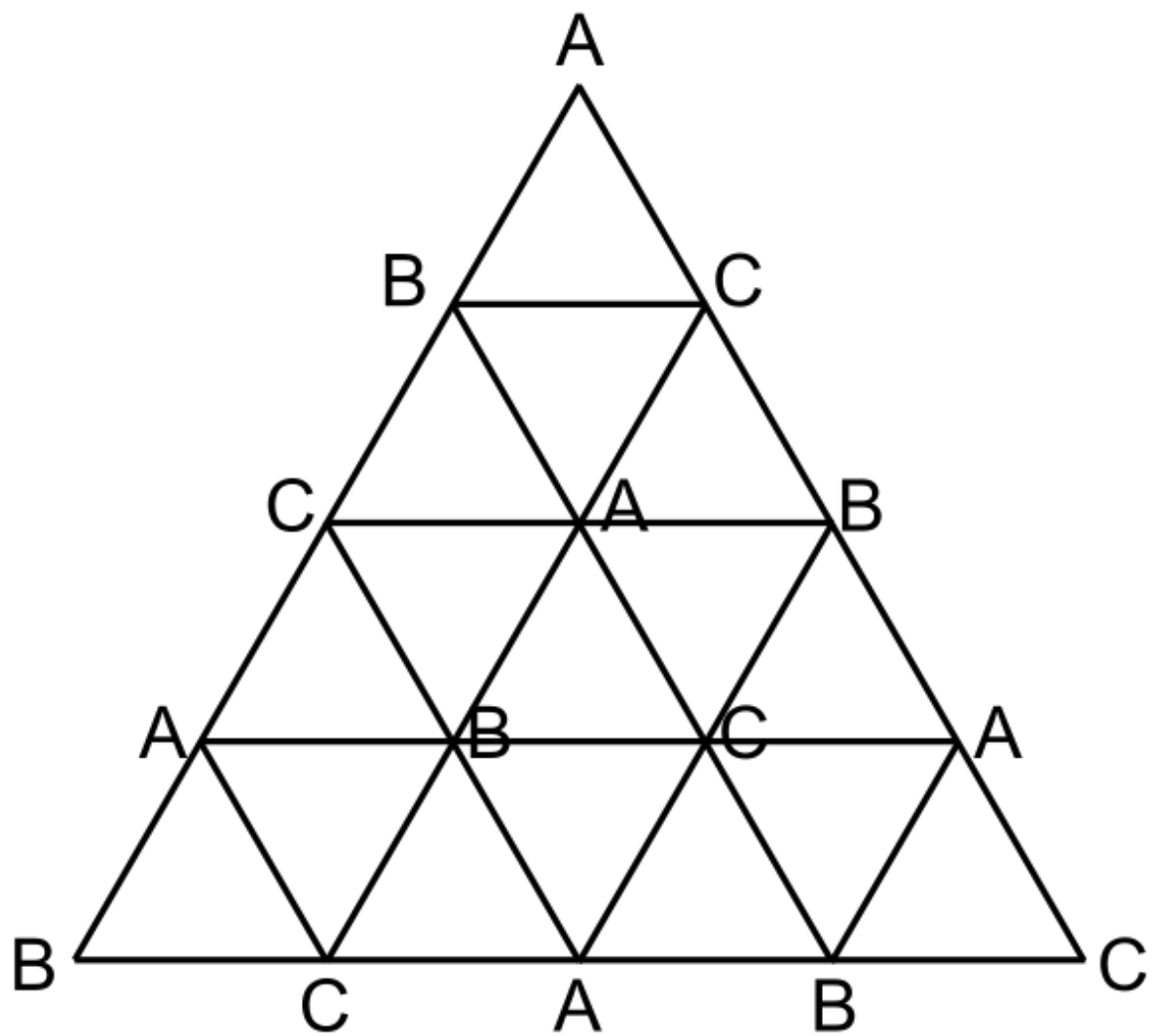

Preference labeling

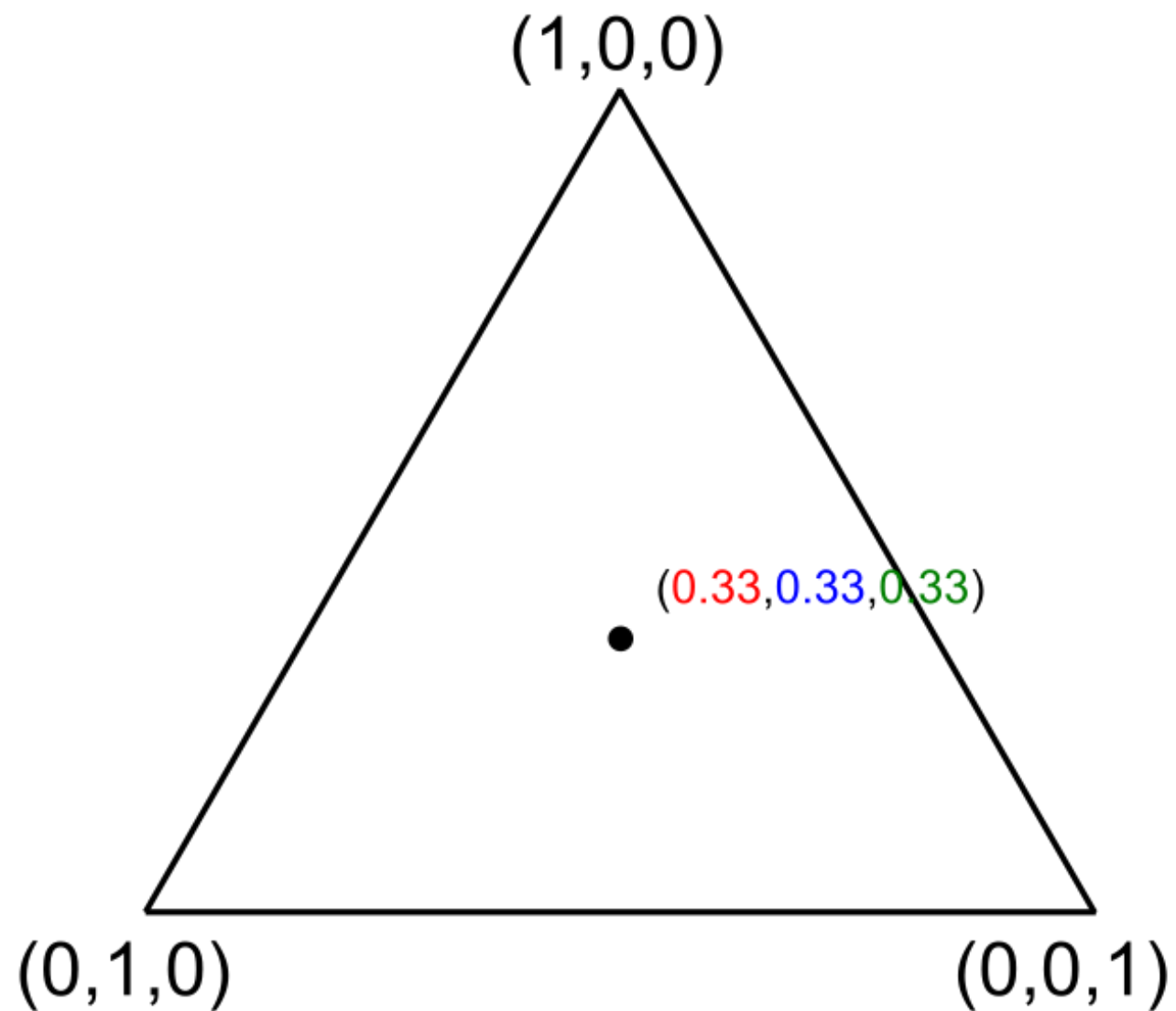

Ownership labeling

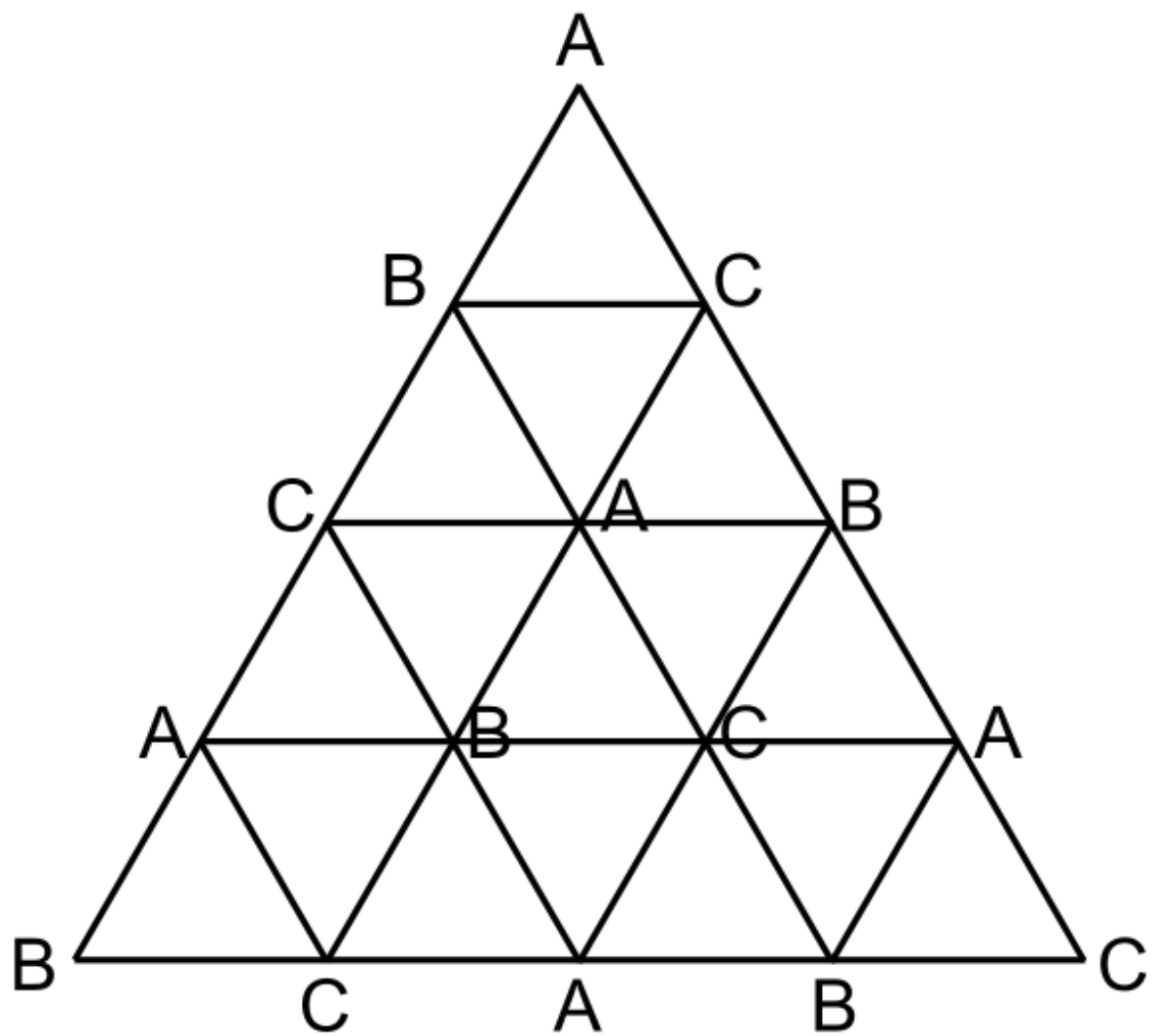

Preference labeling

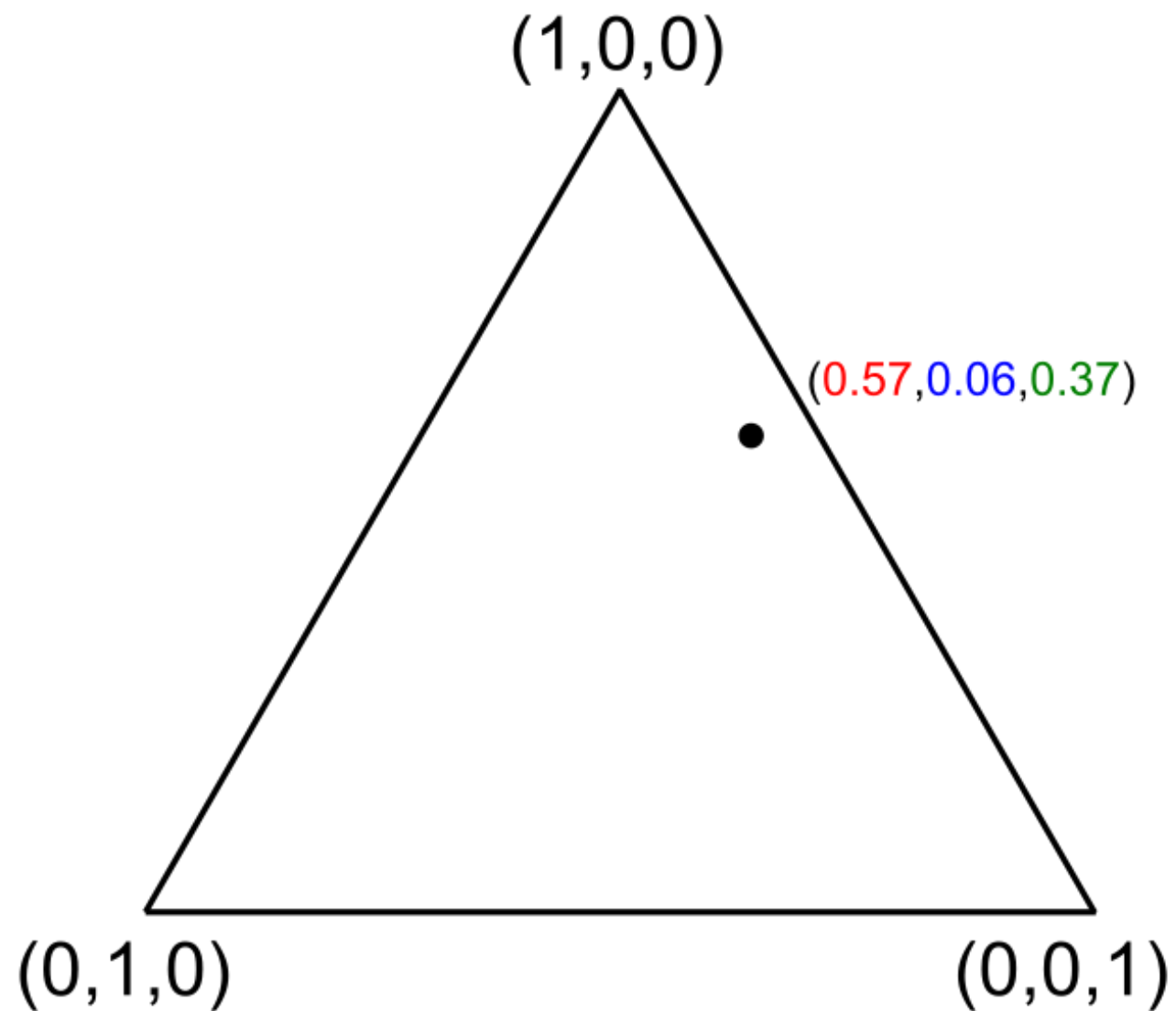

Ownership labeling

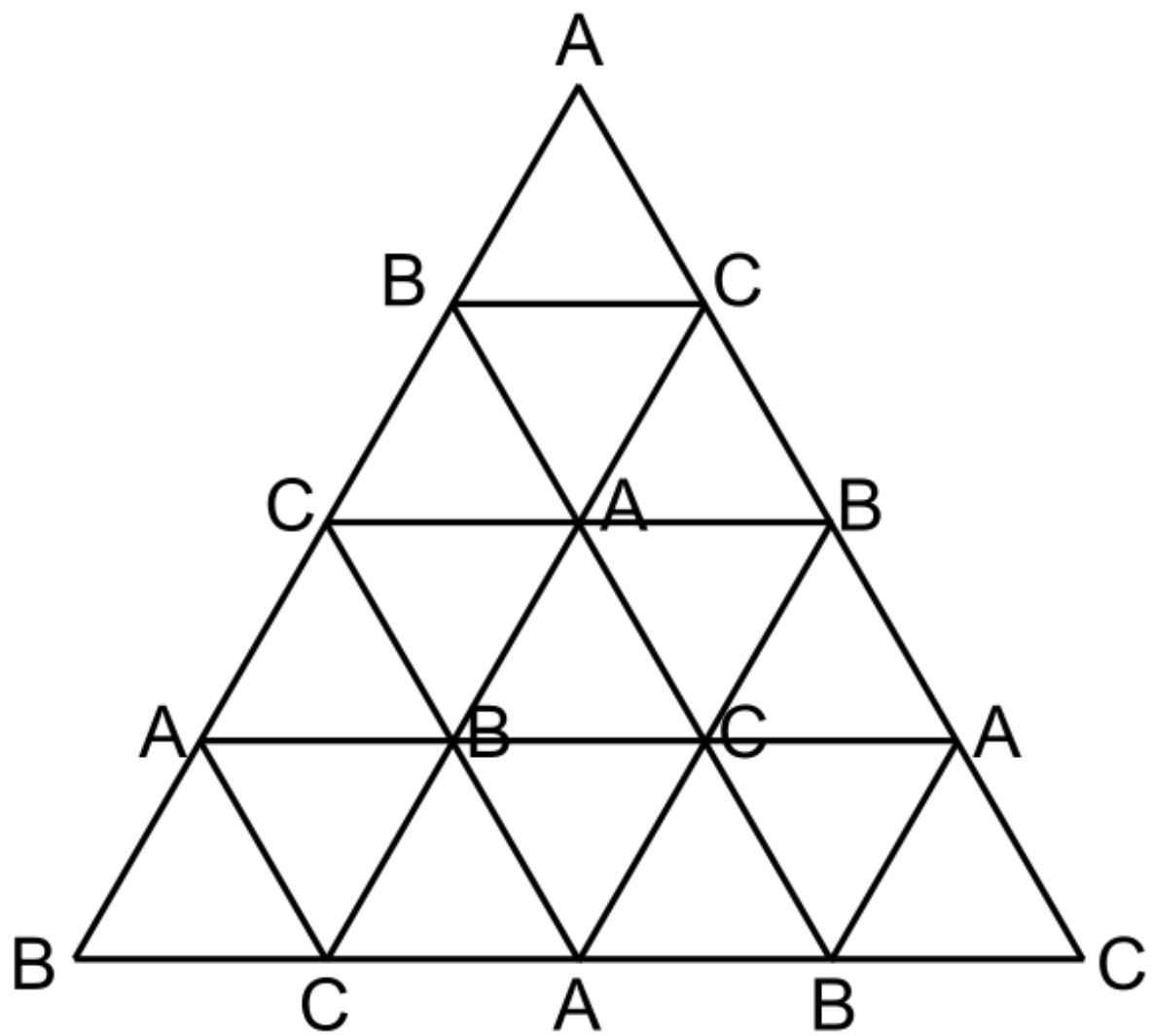

Preference labeling

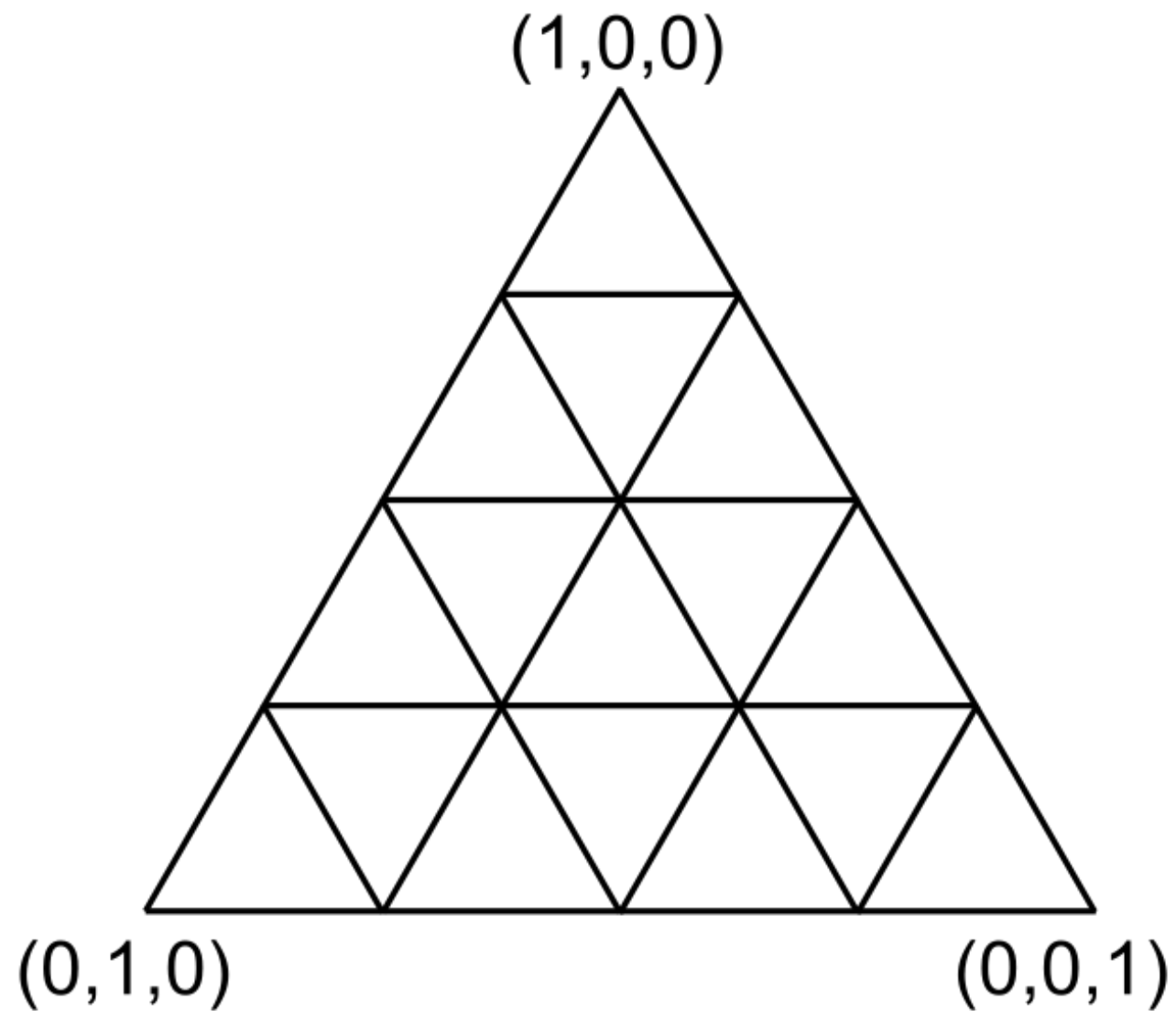

For each vertex in the ownership triangle, ask the owner its favorite room at the pricing given in the preference triangle.

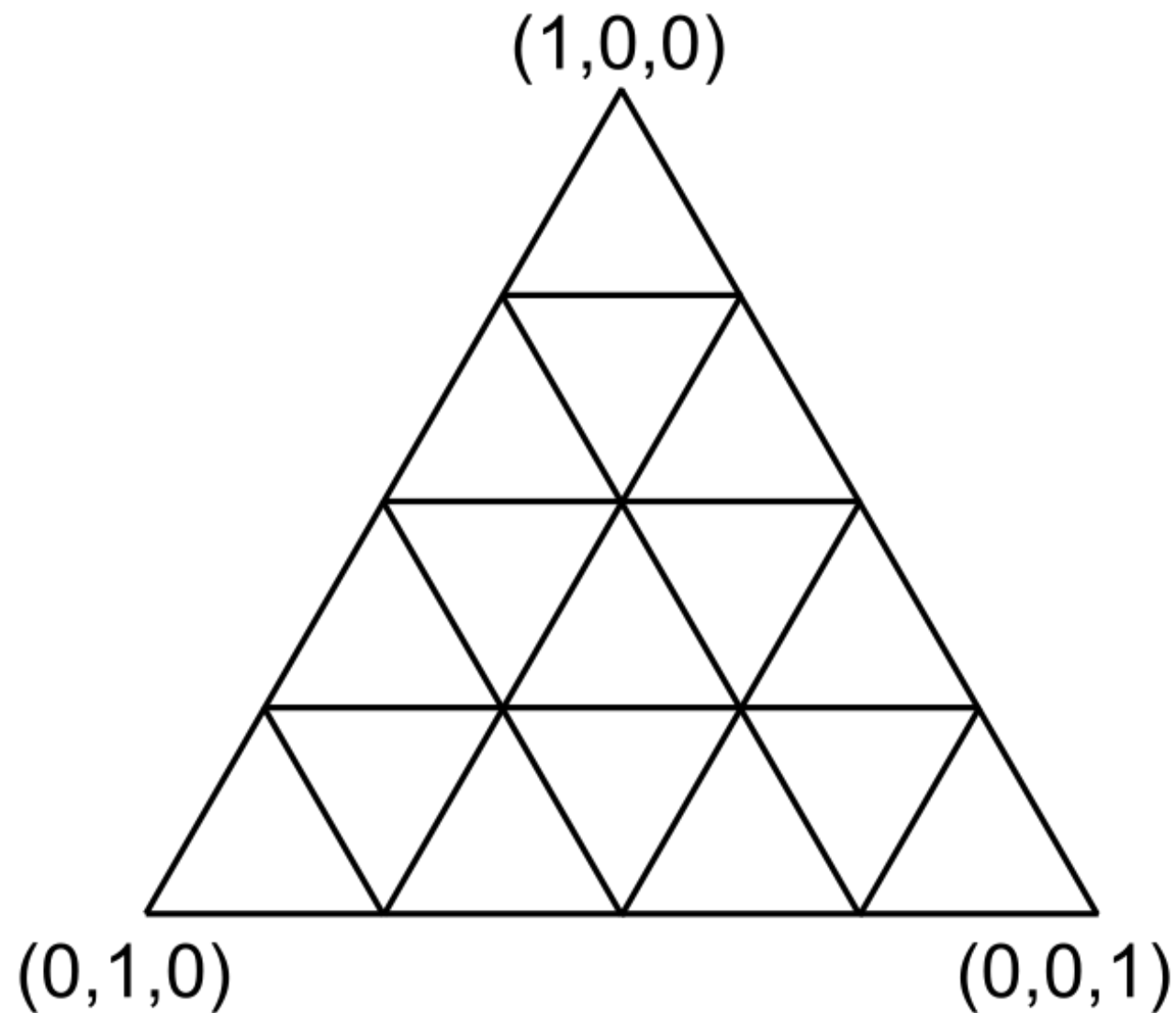
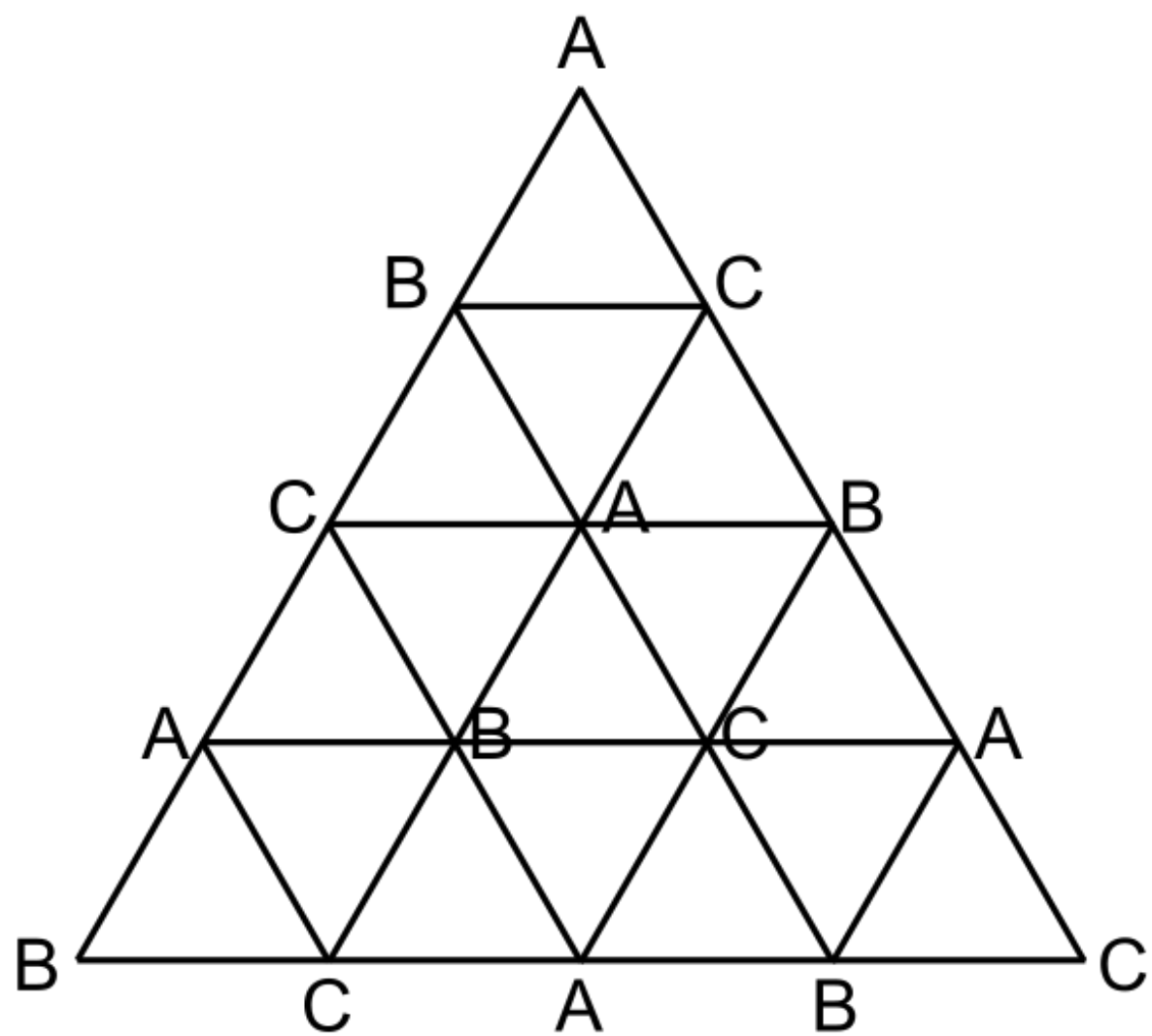

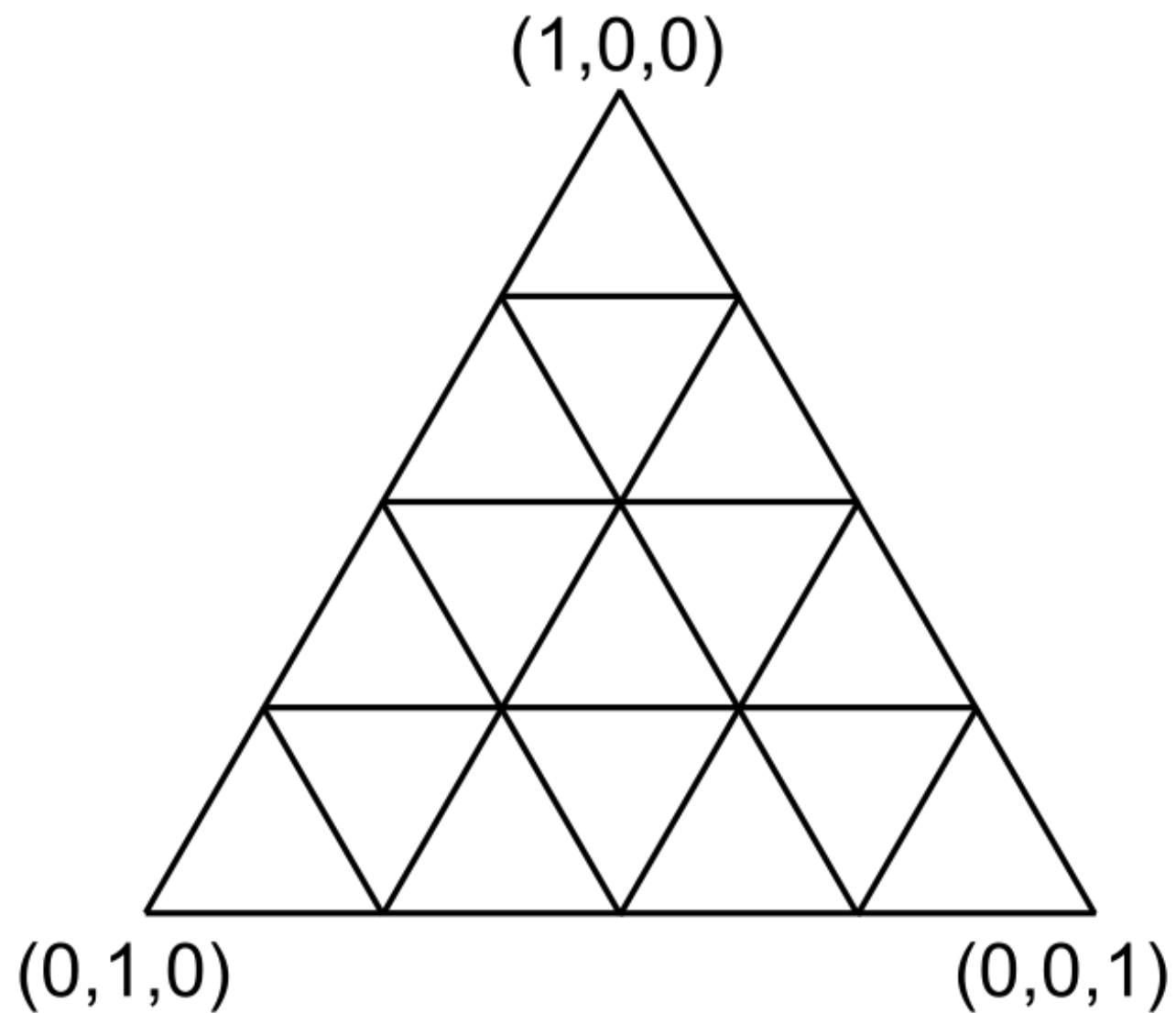
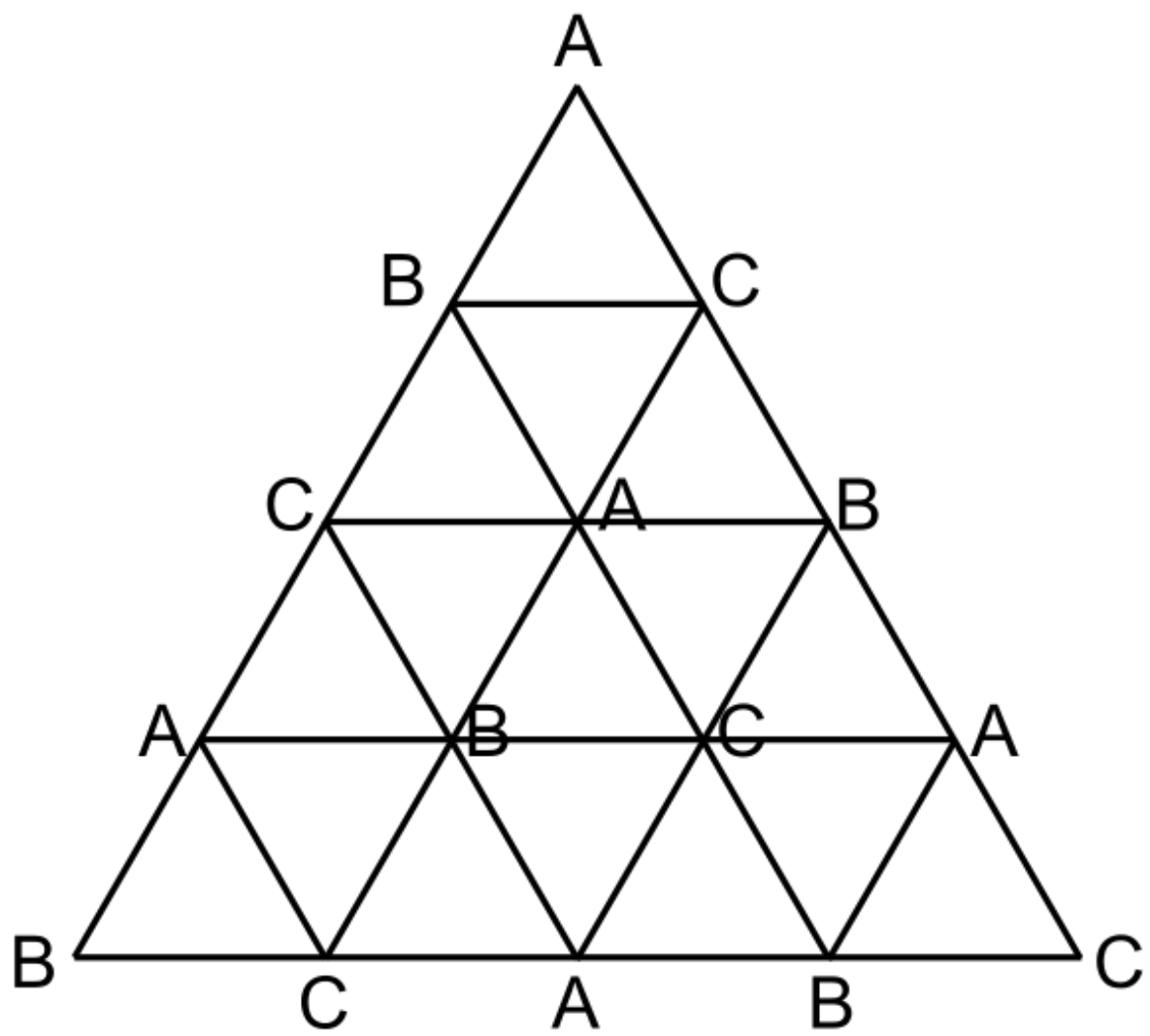

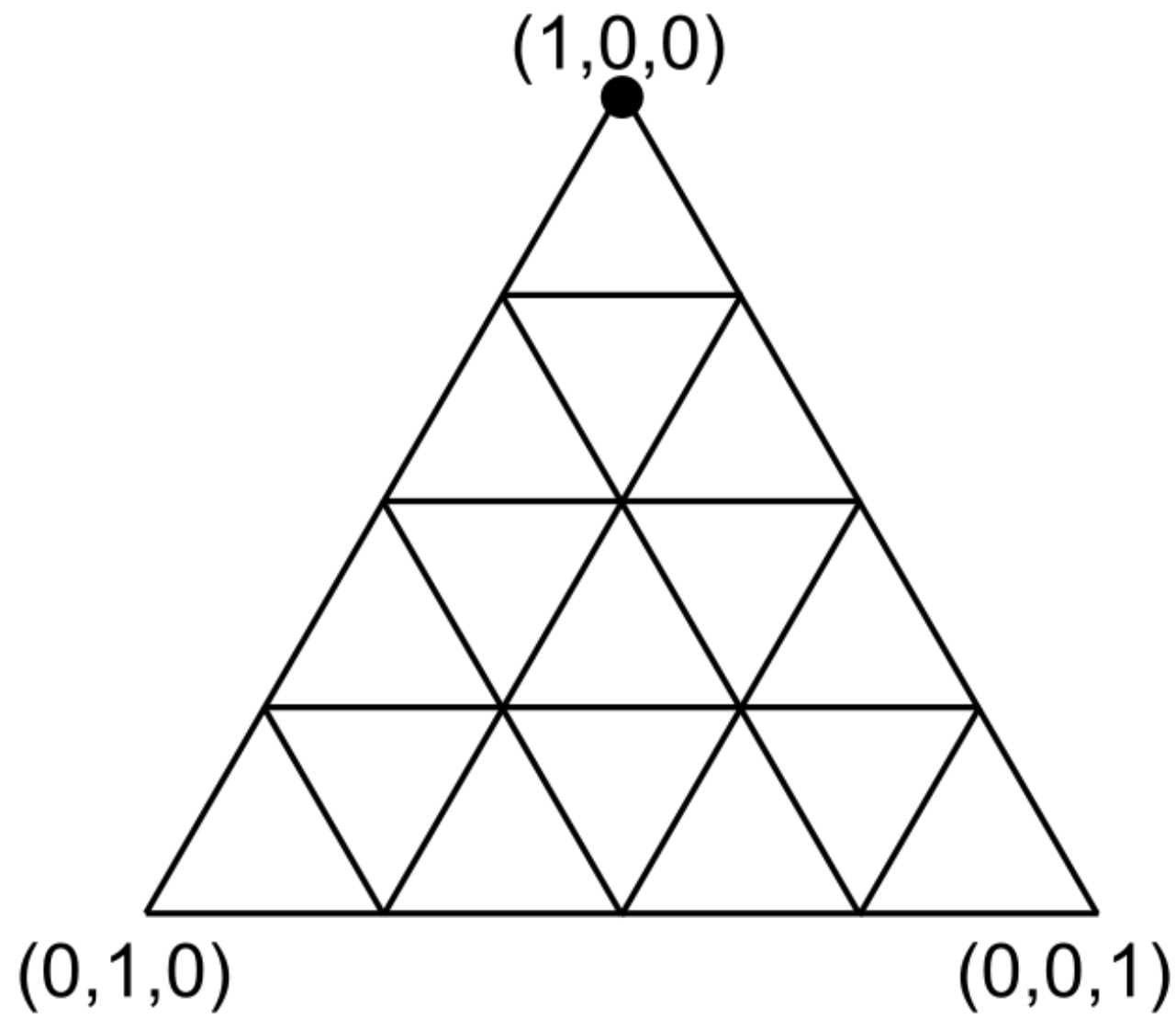
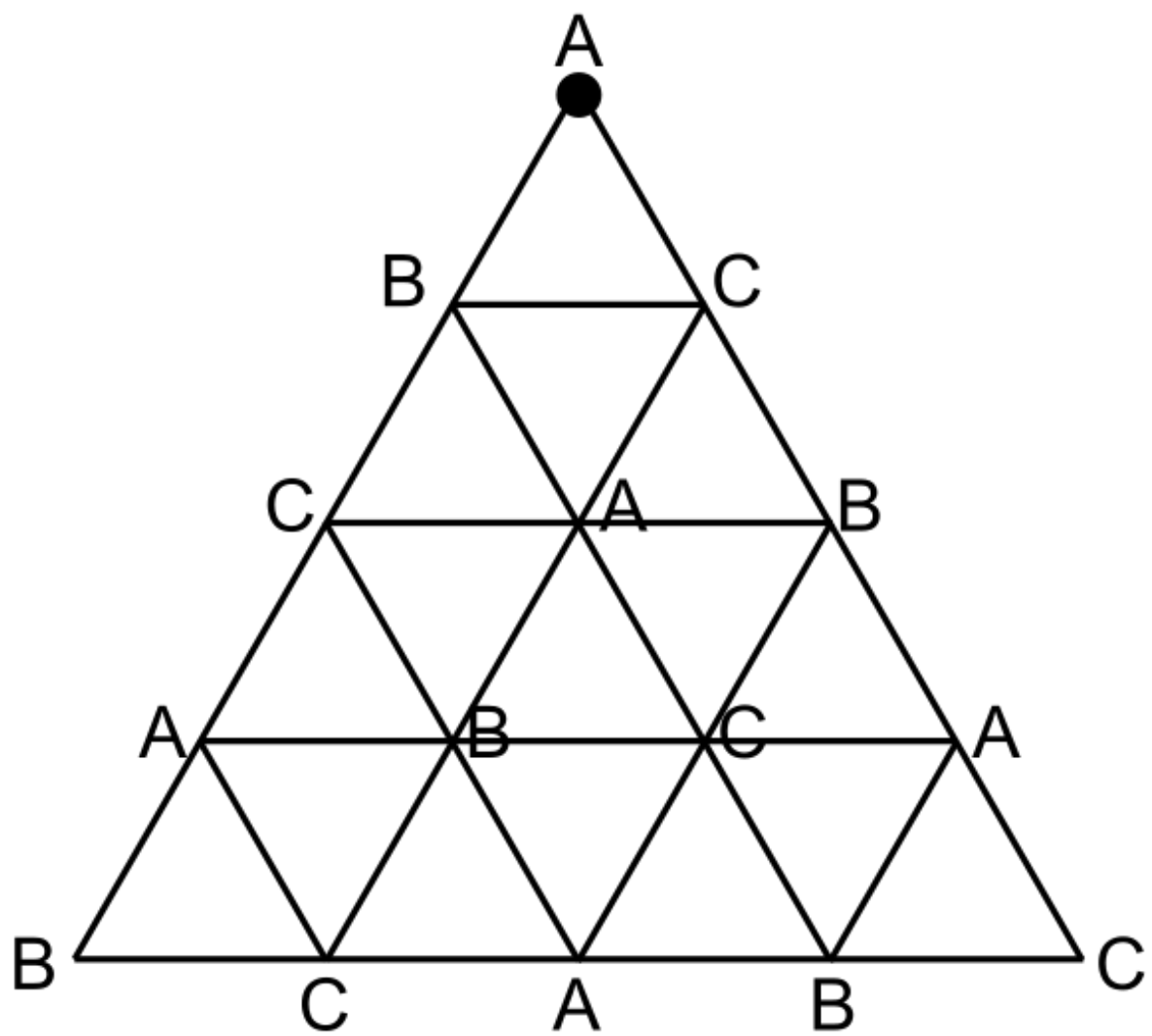

"Miserly agents" assumption
Agents always prefer a *free* room over a room with non-zero rent.

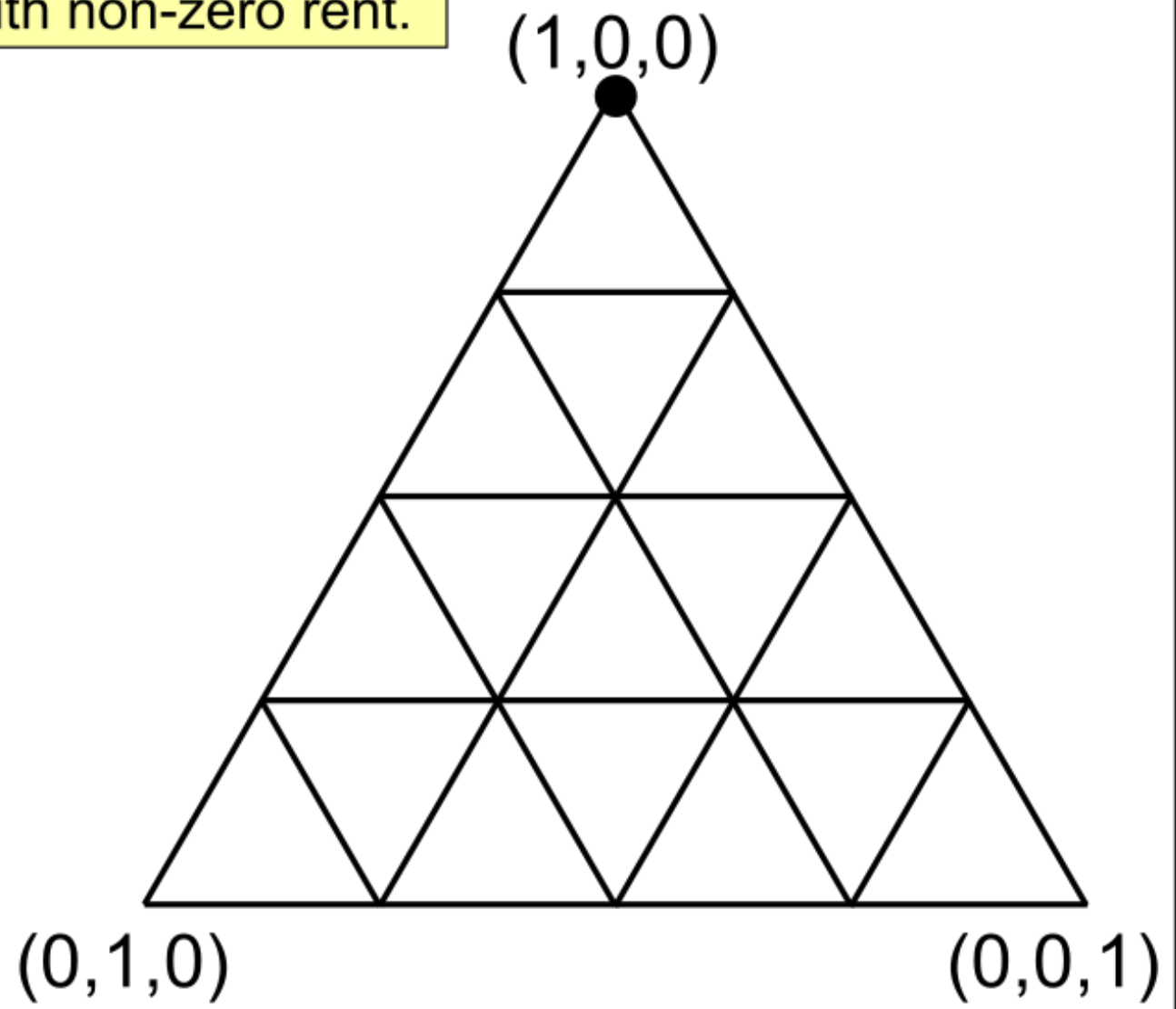
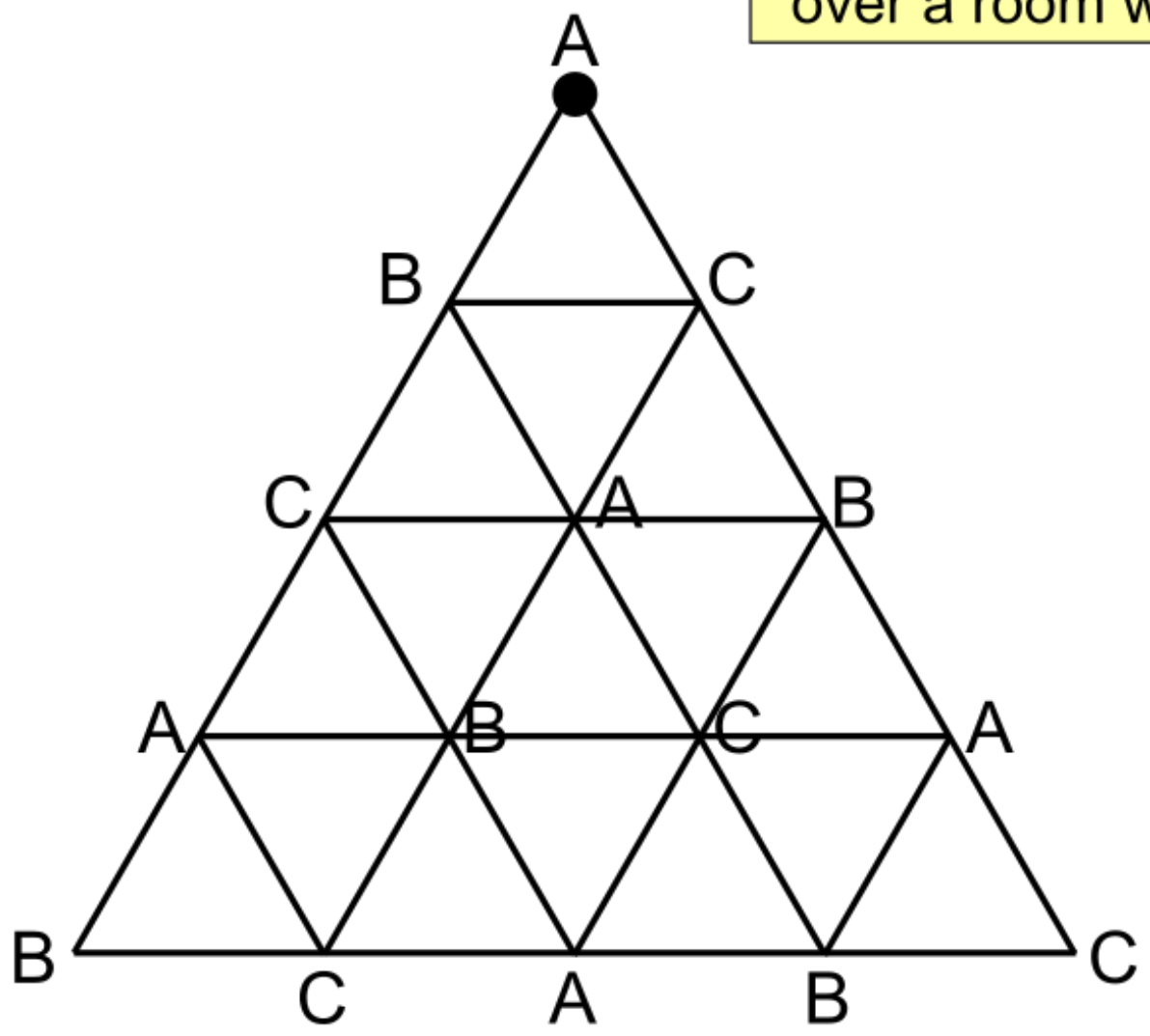

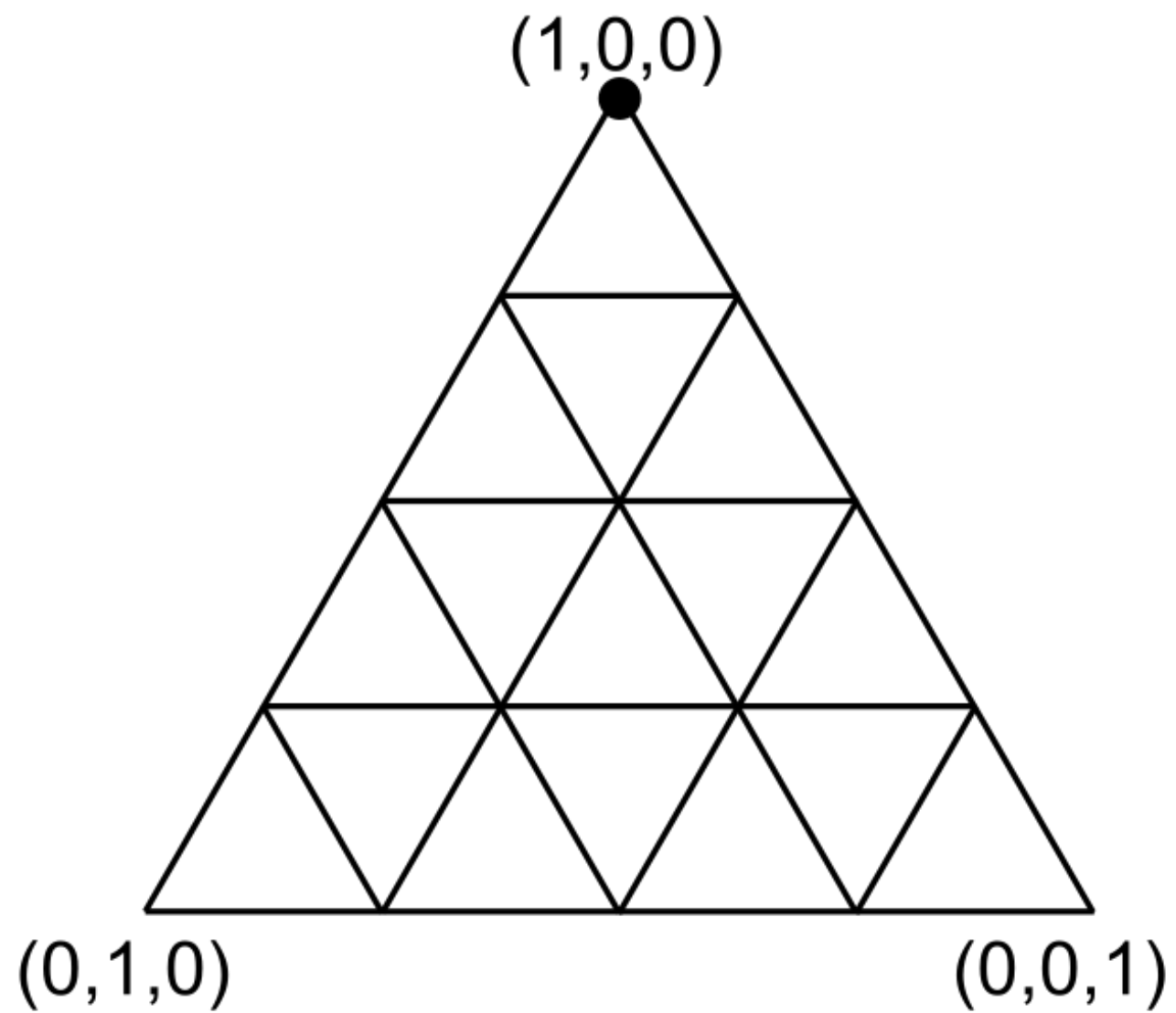
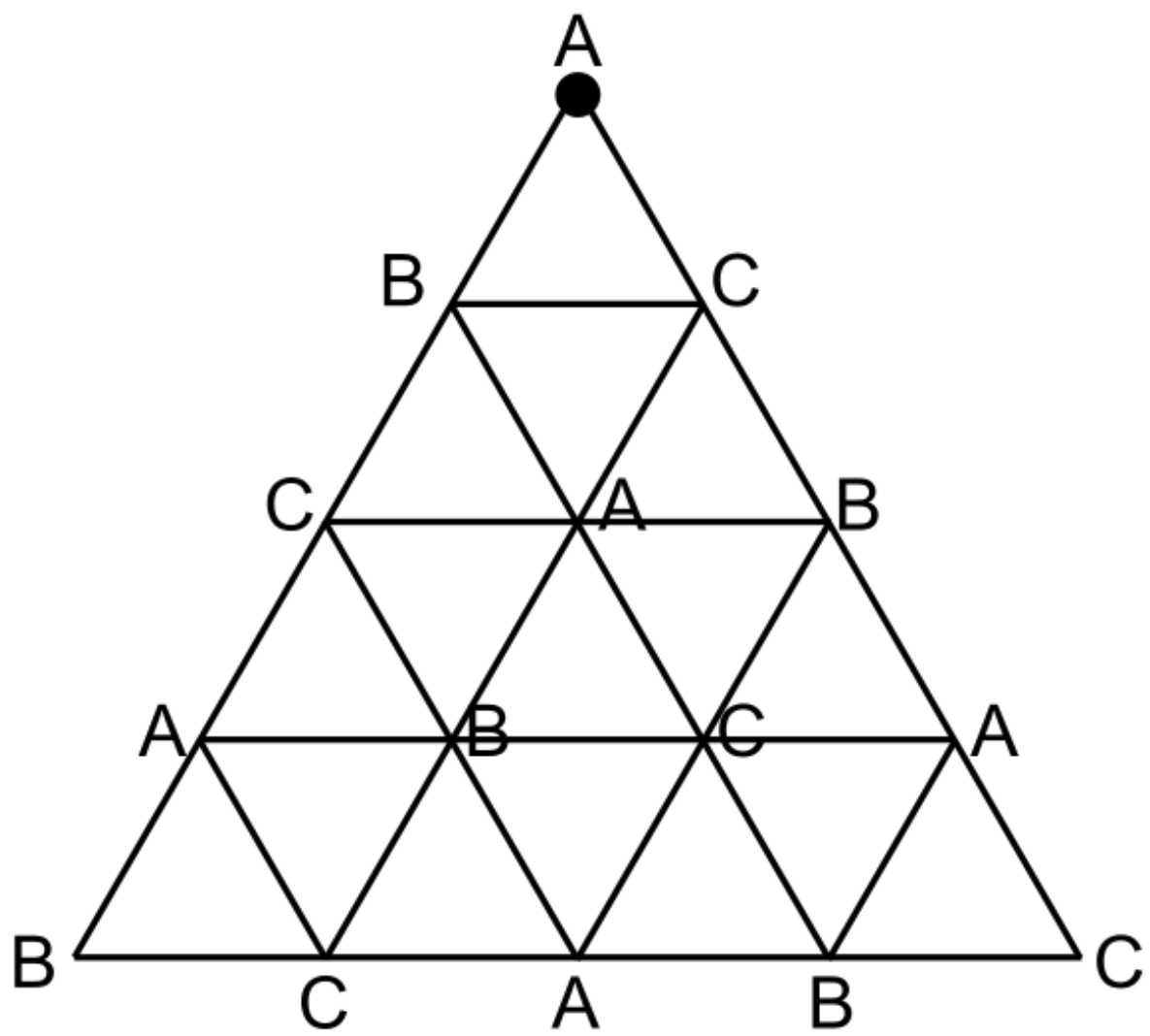

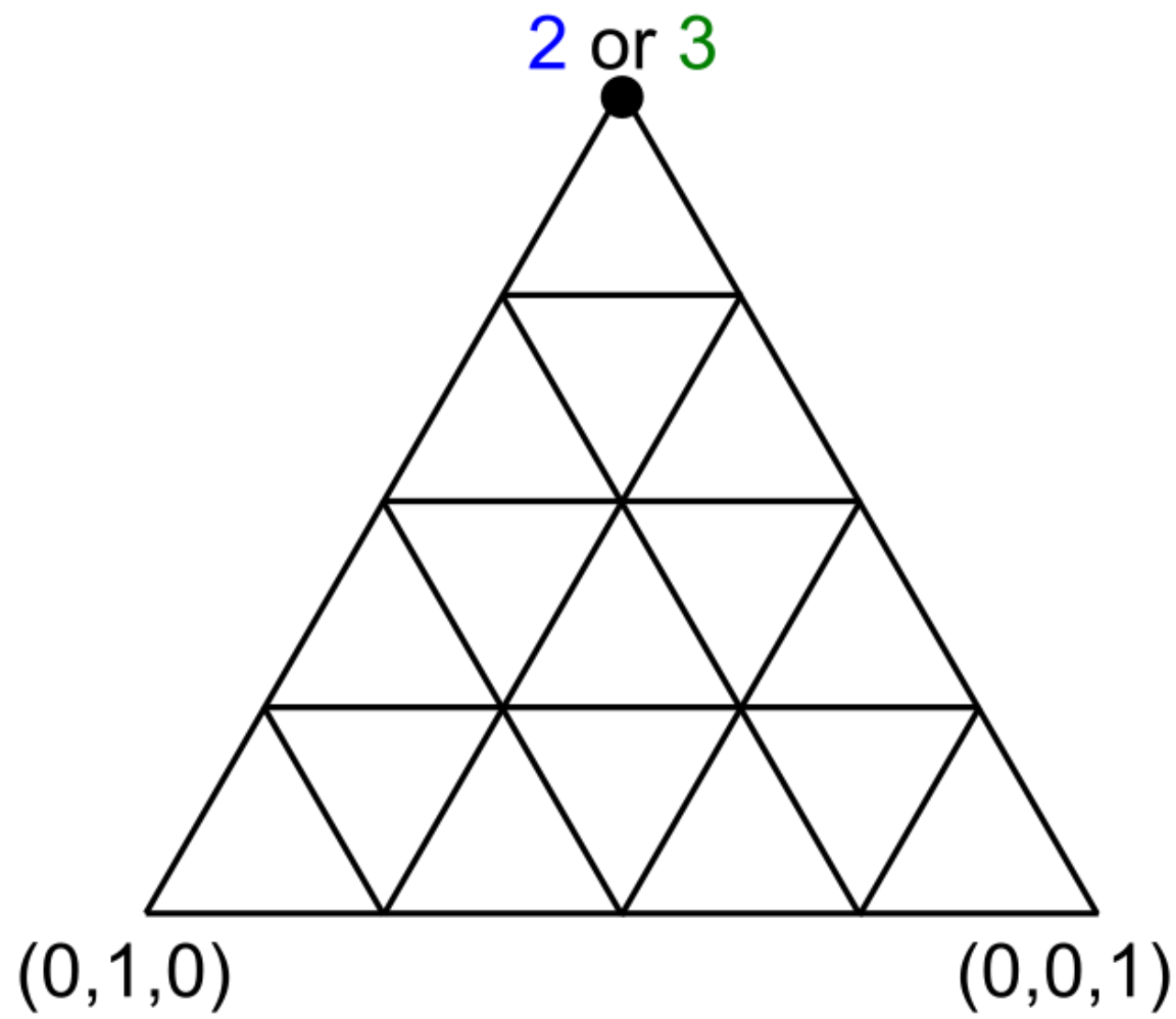
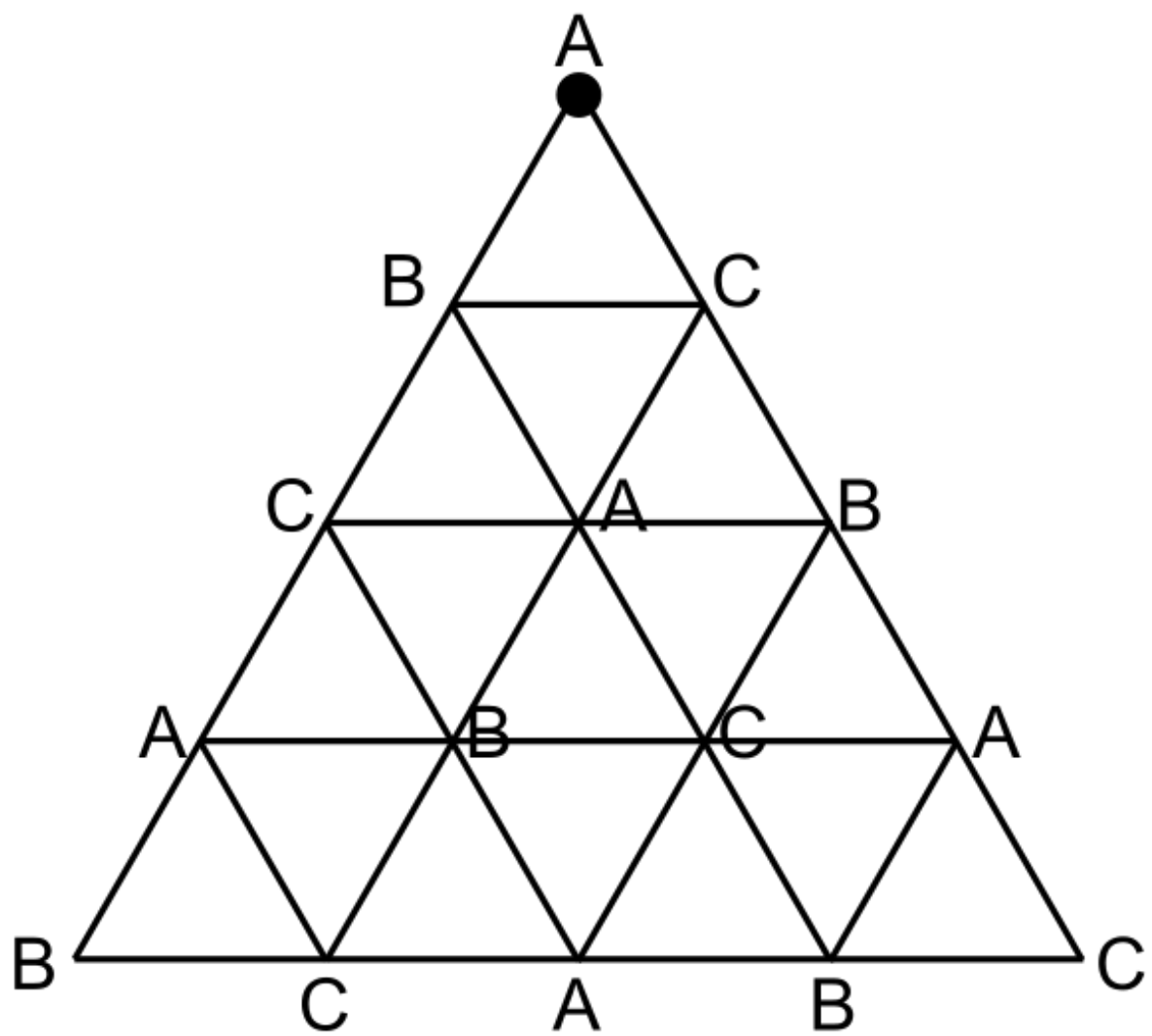

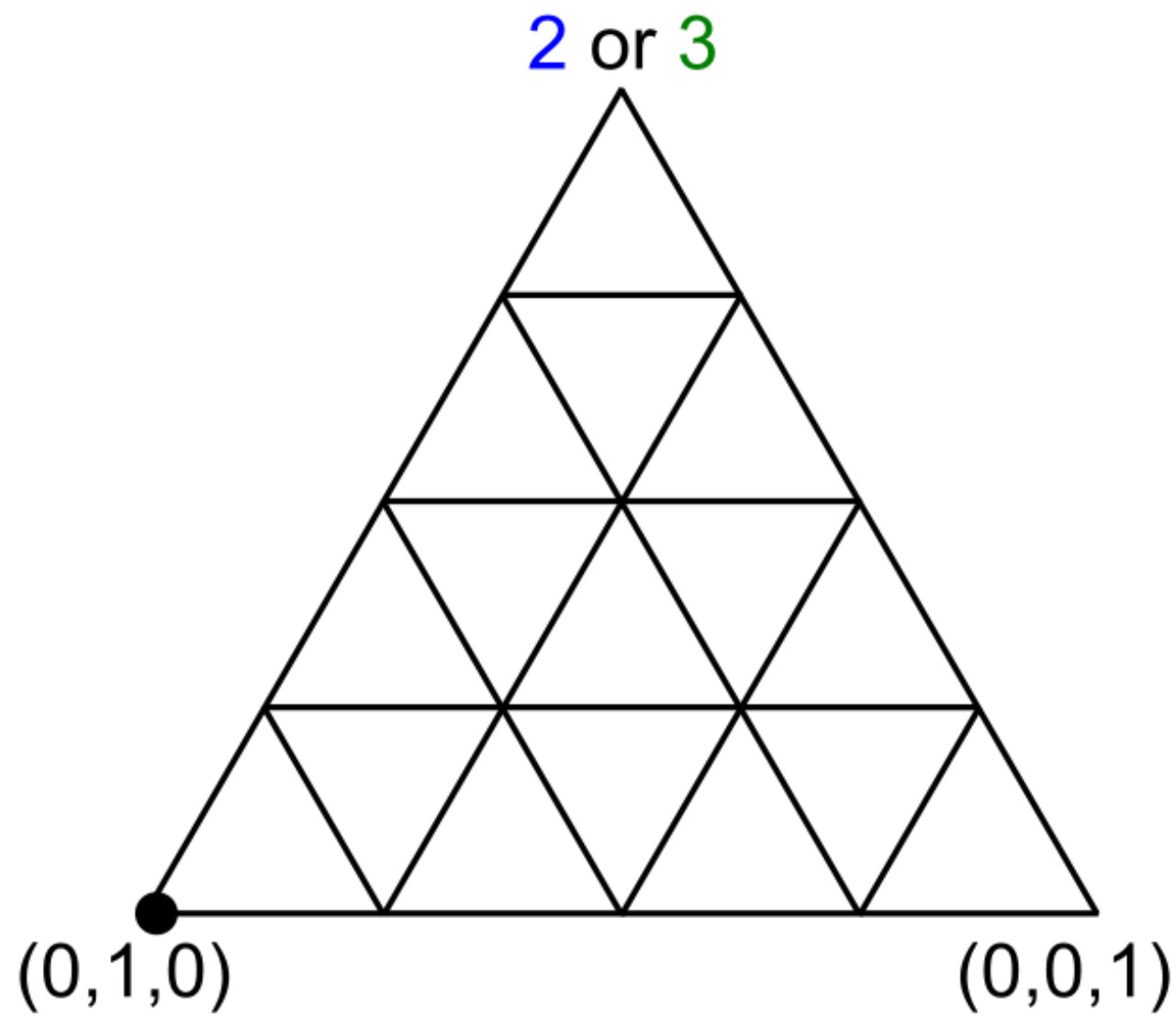
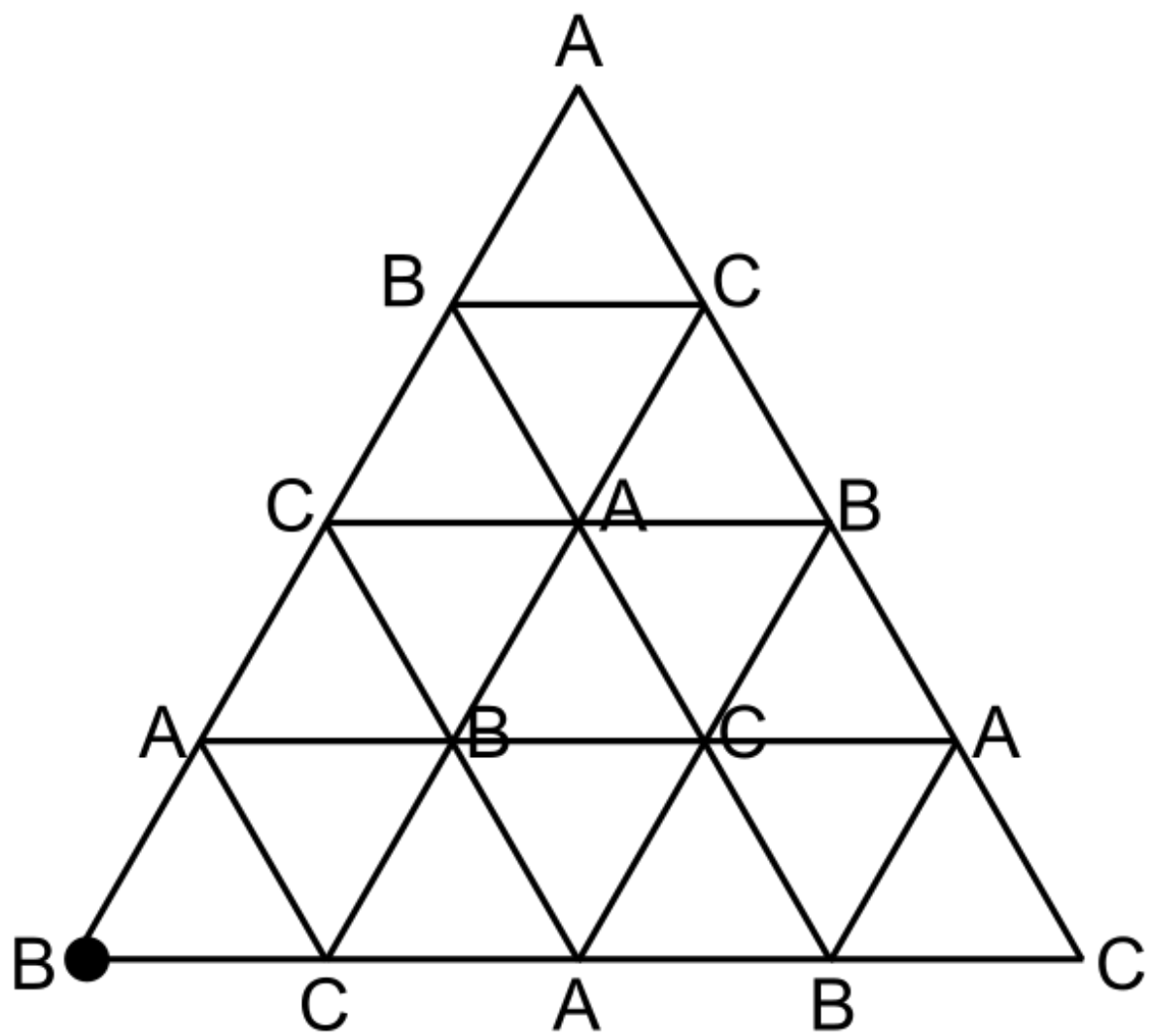

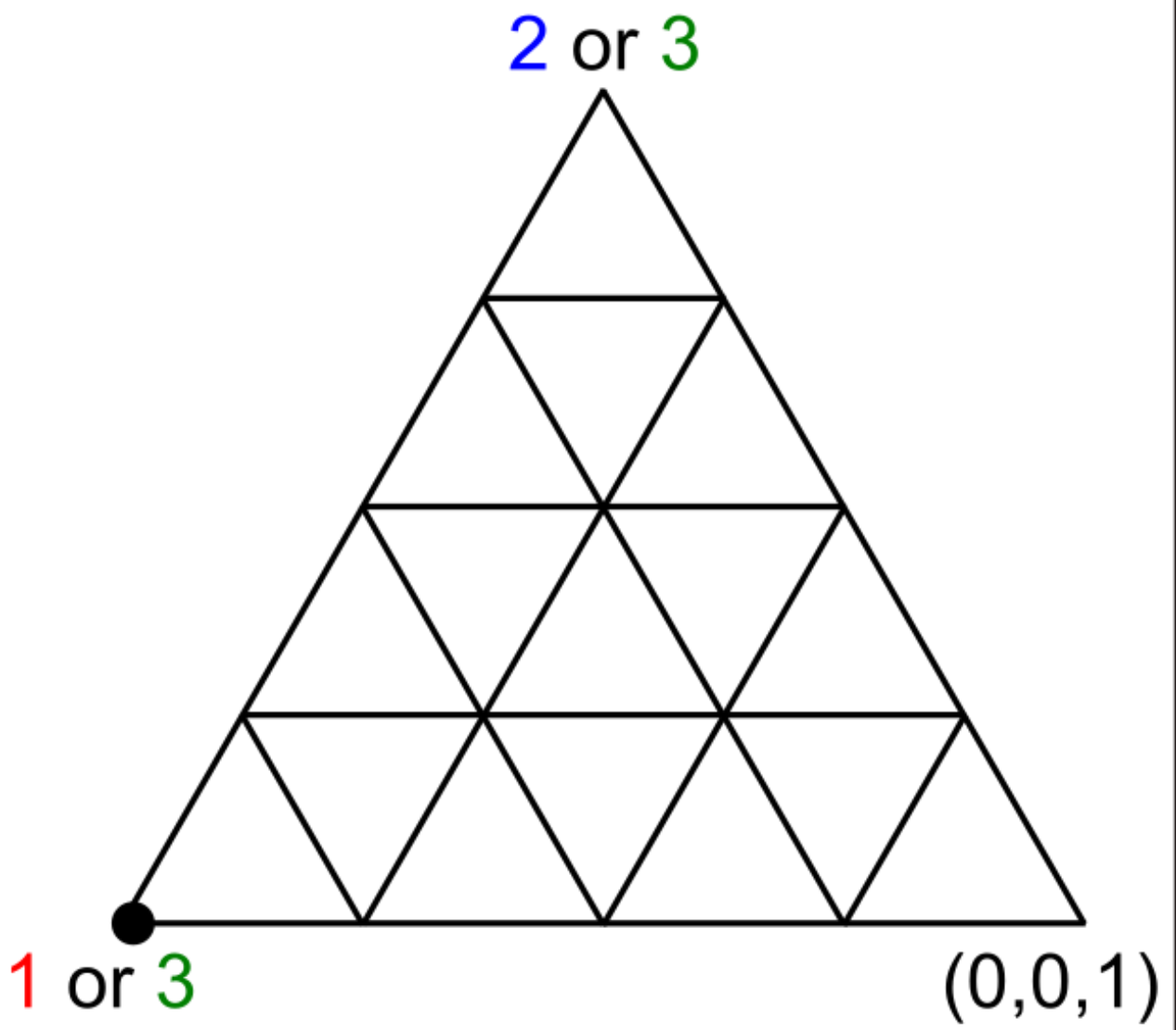
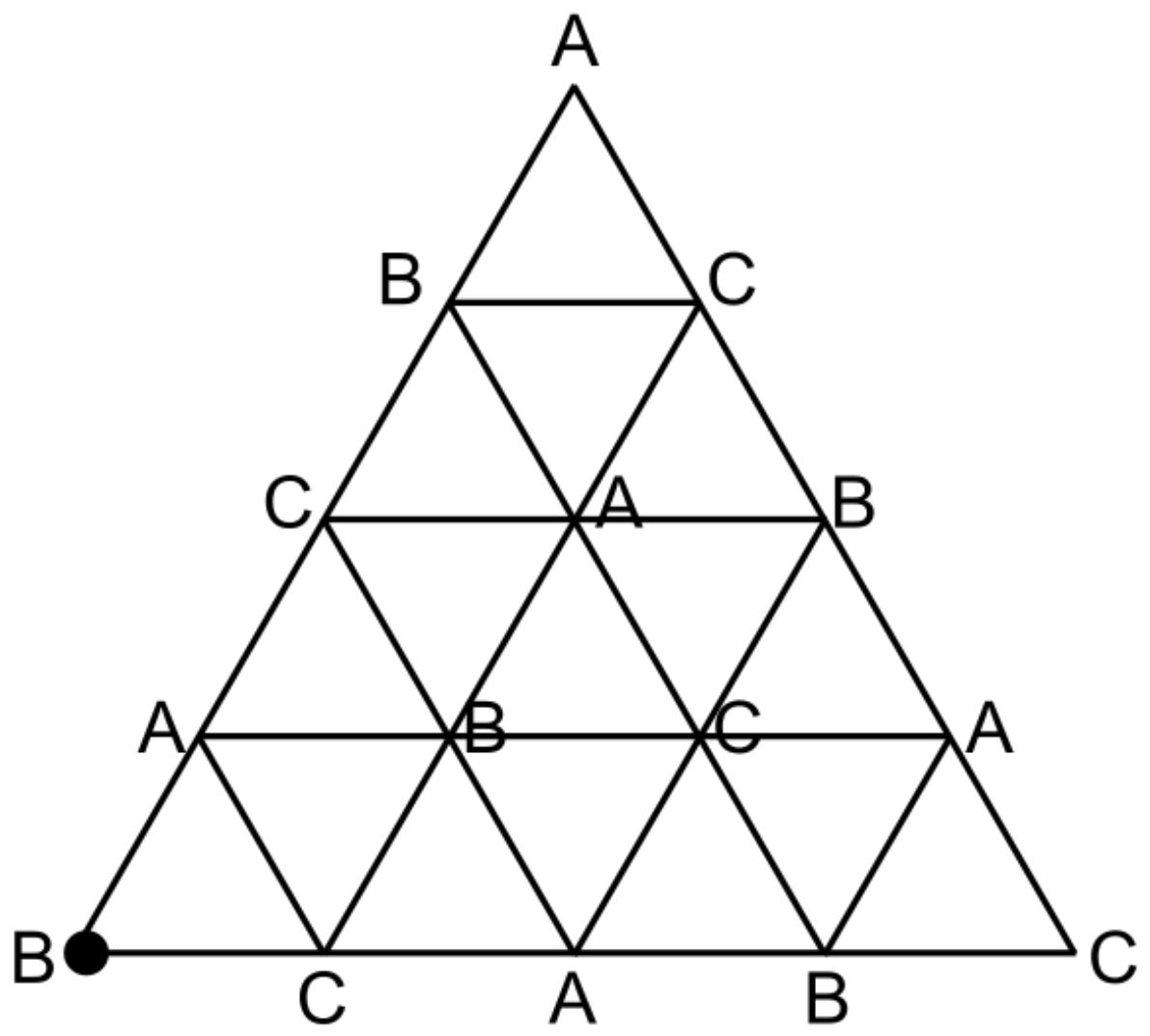

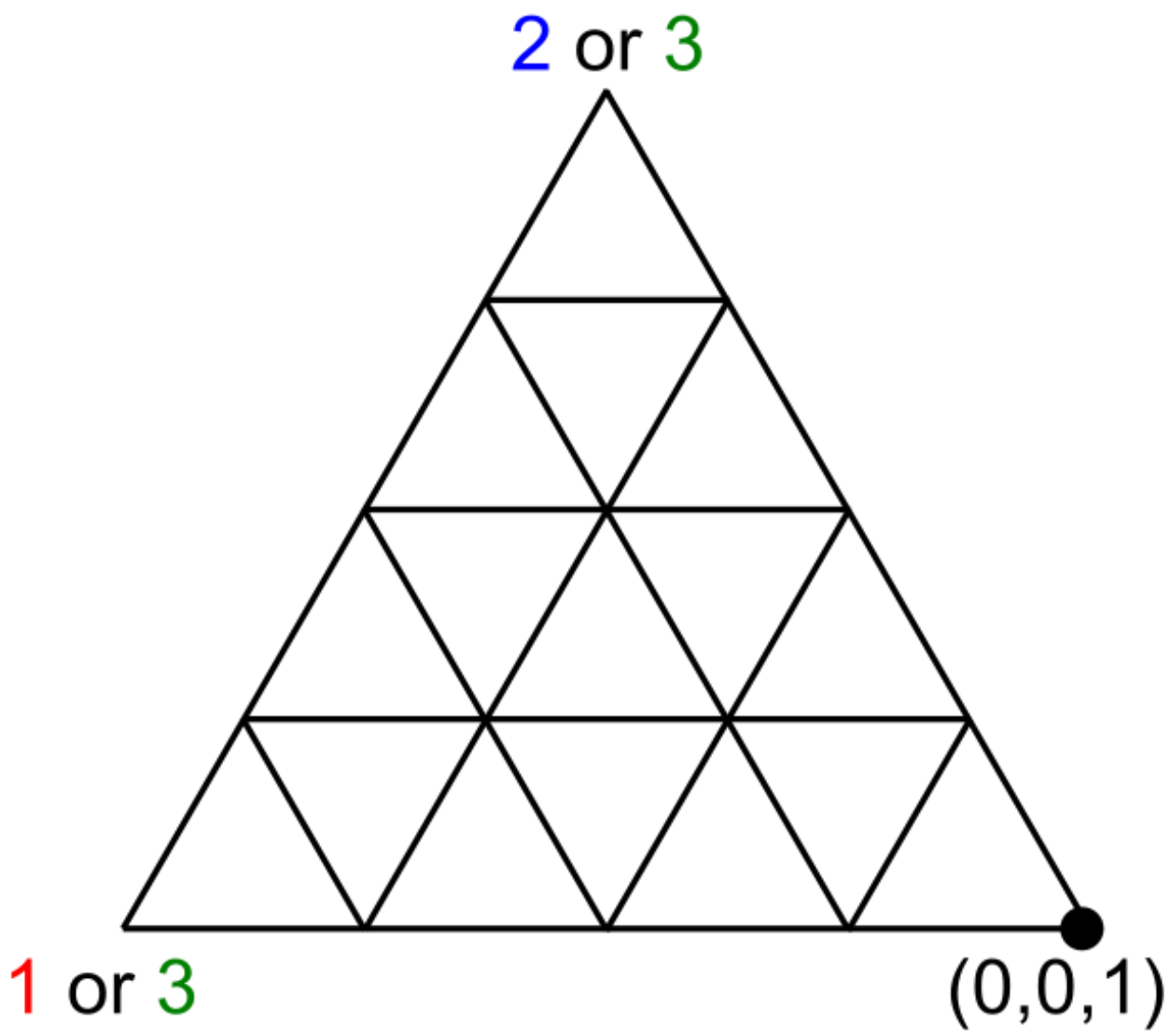
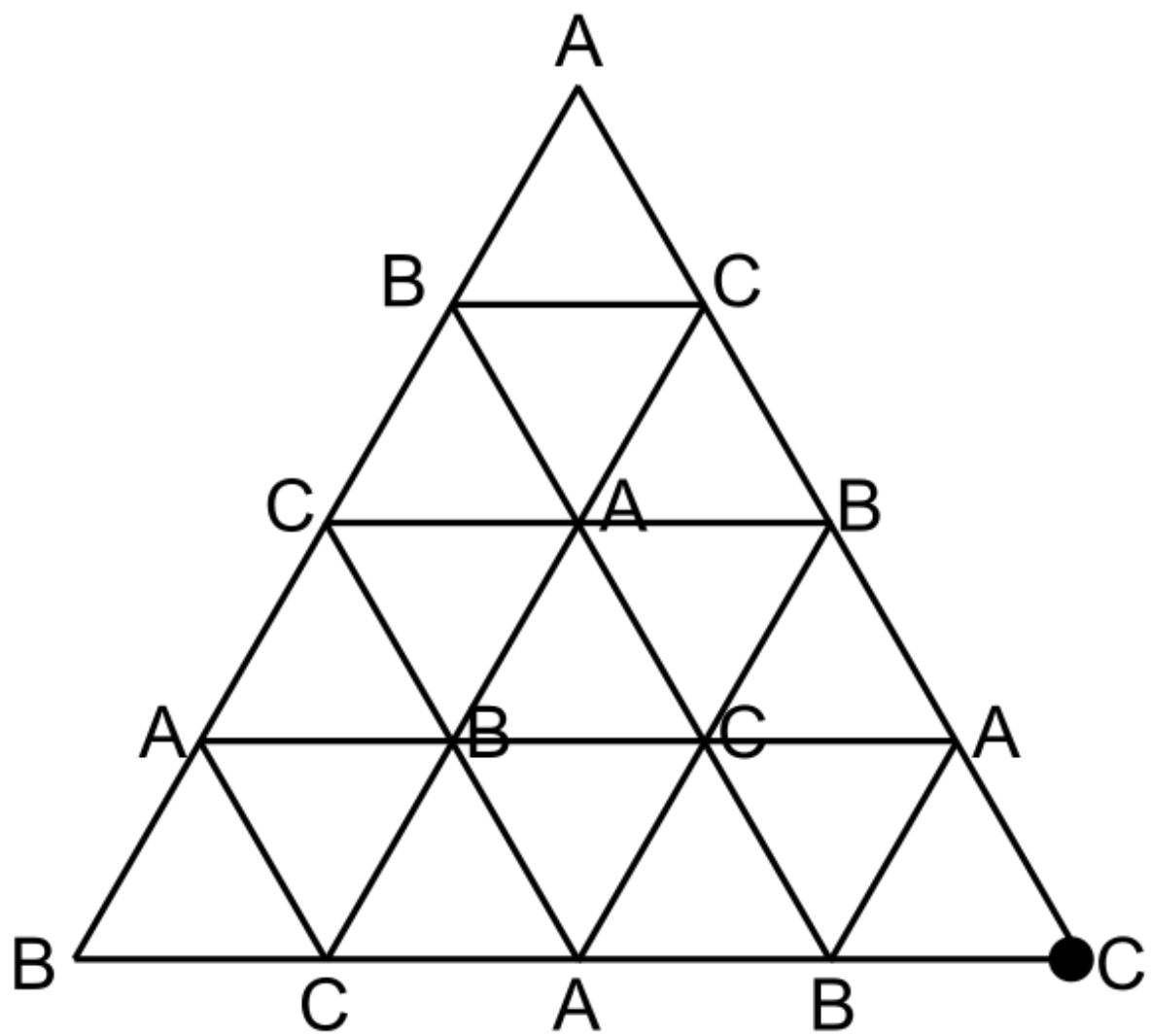

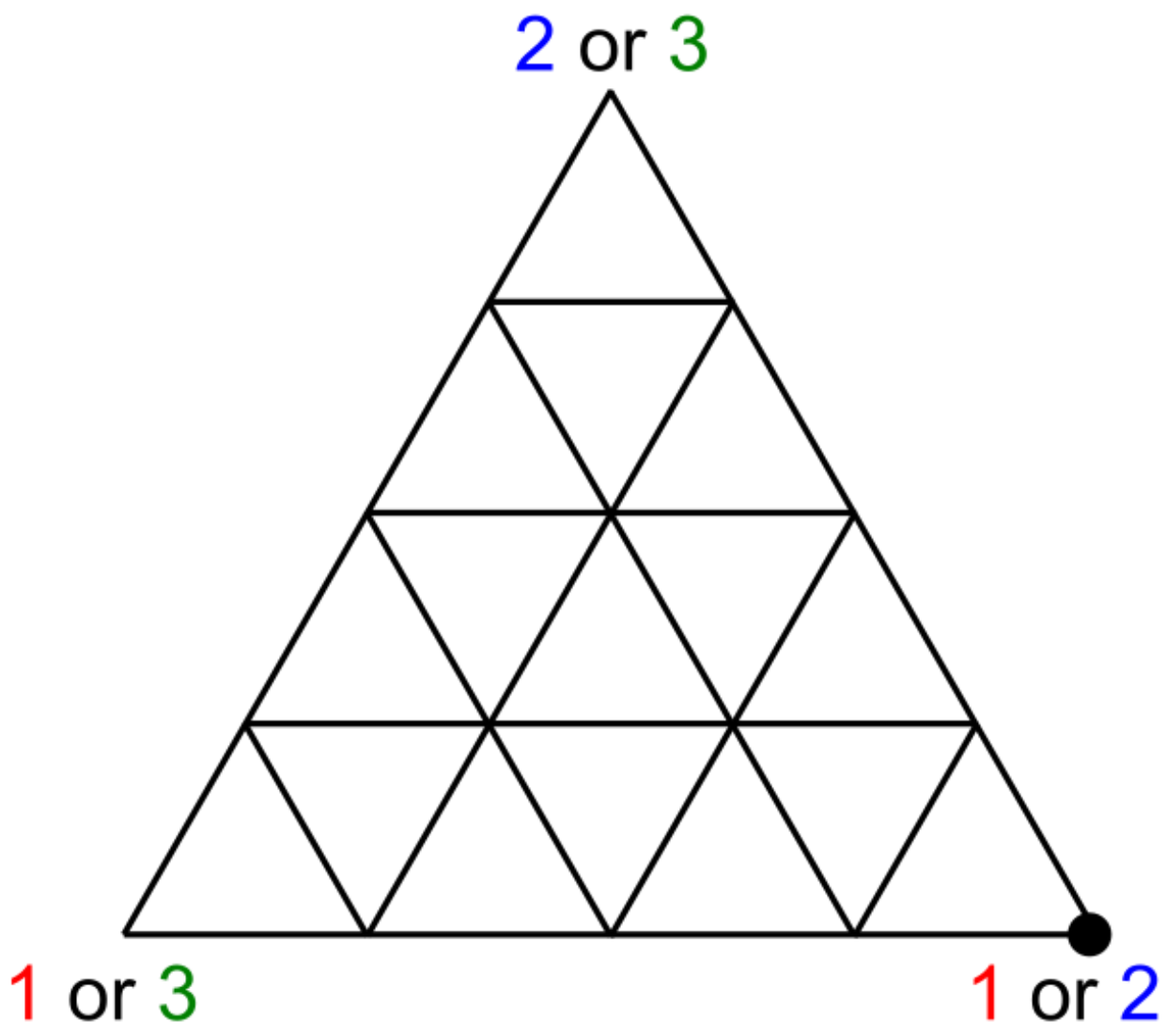
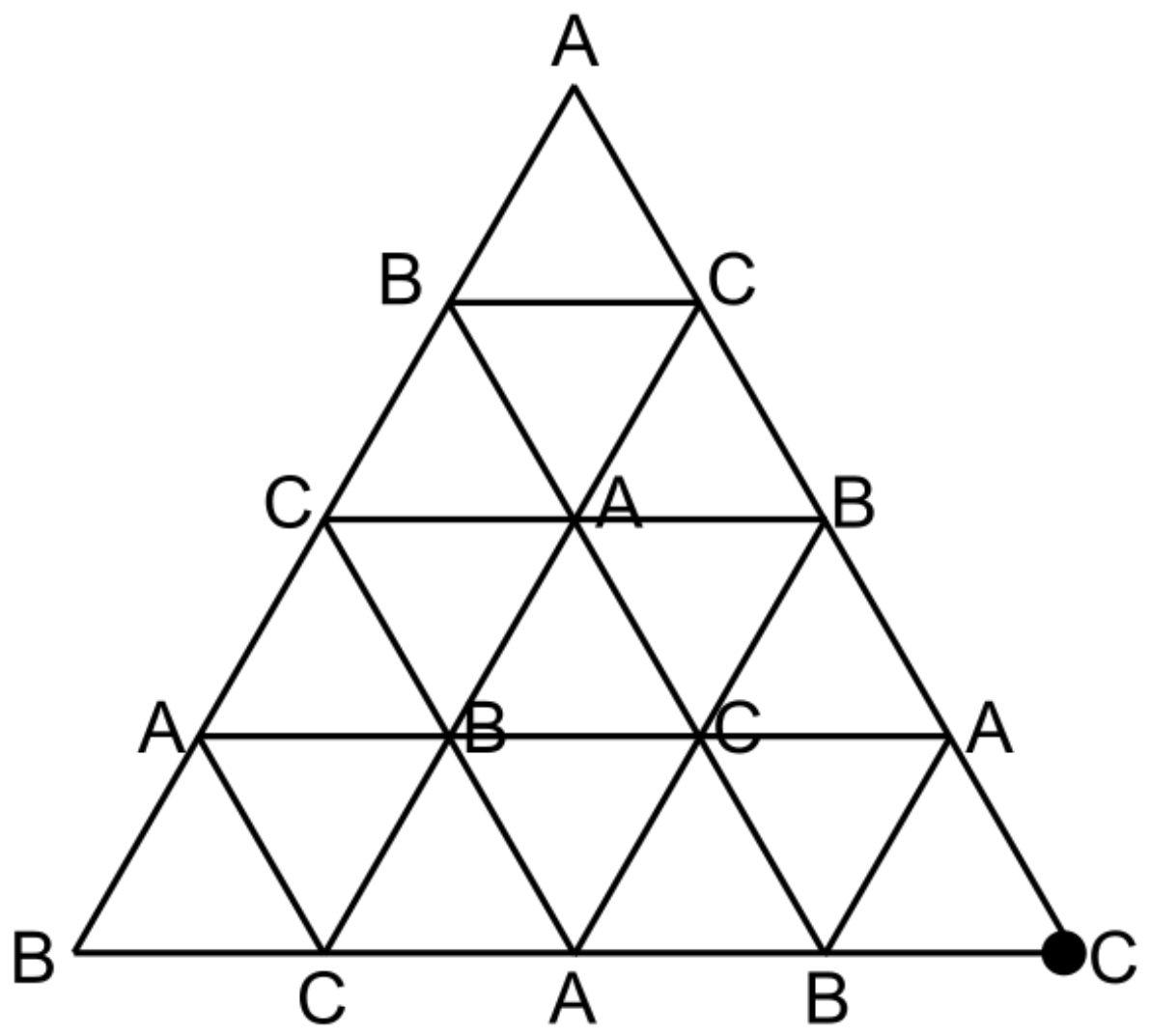

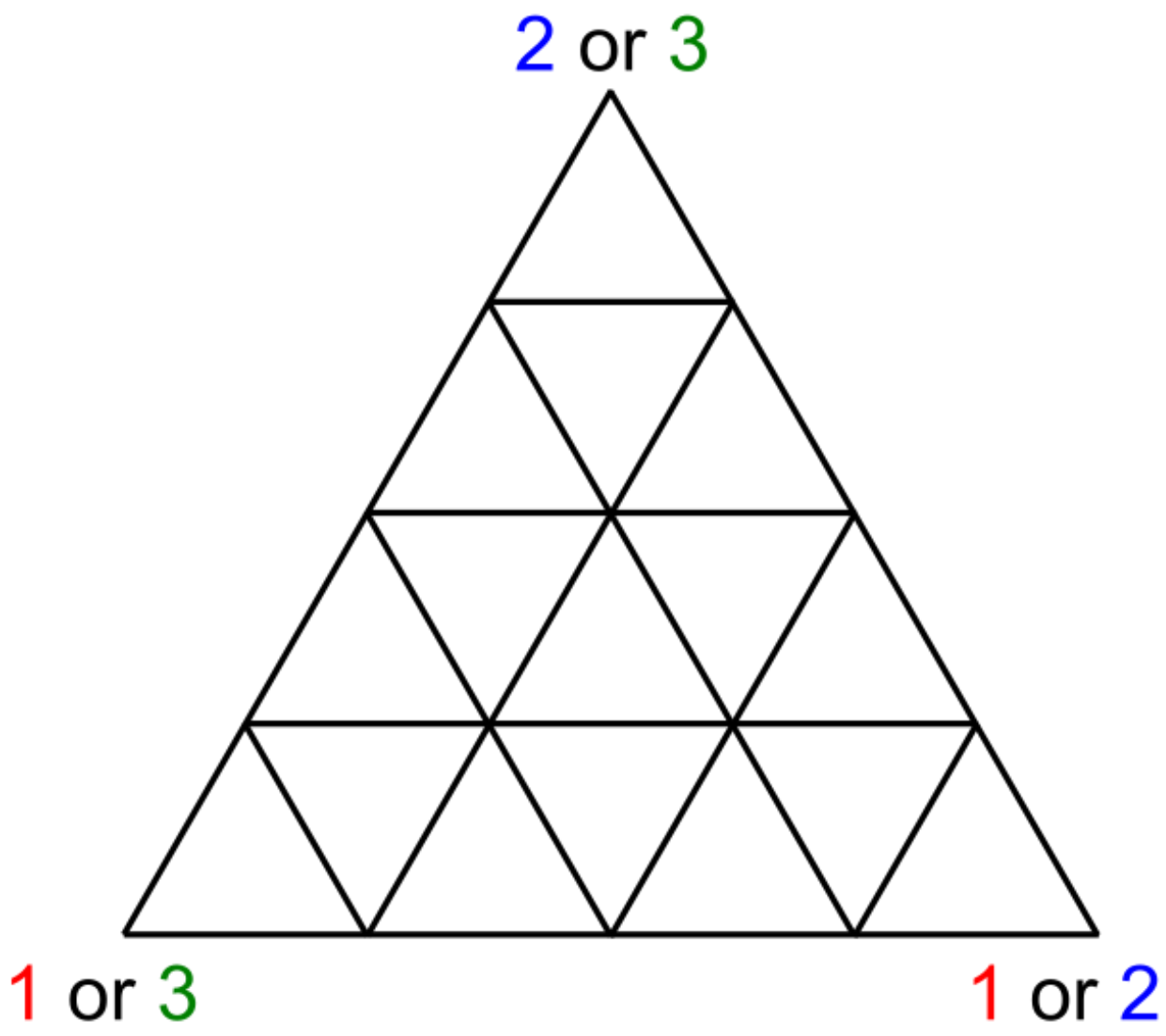
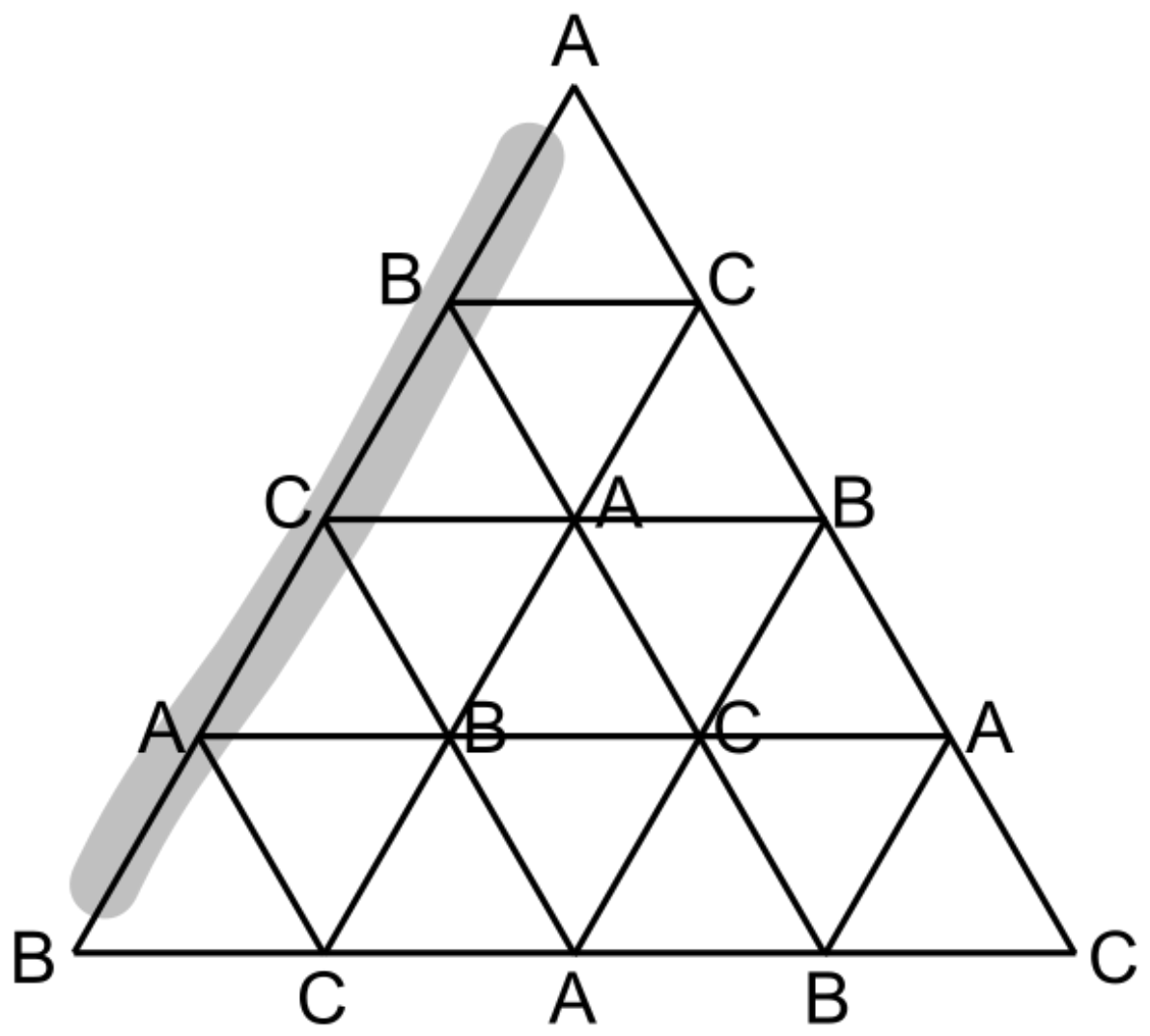

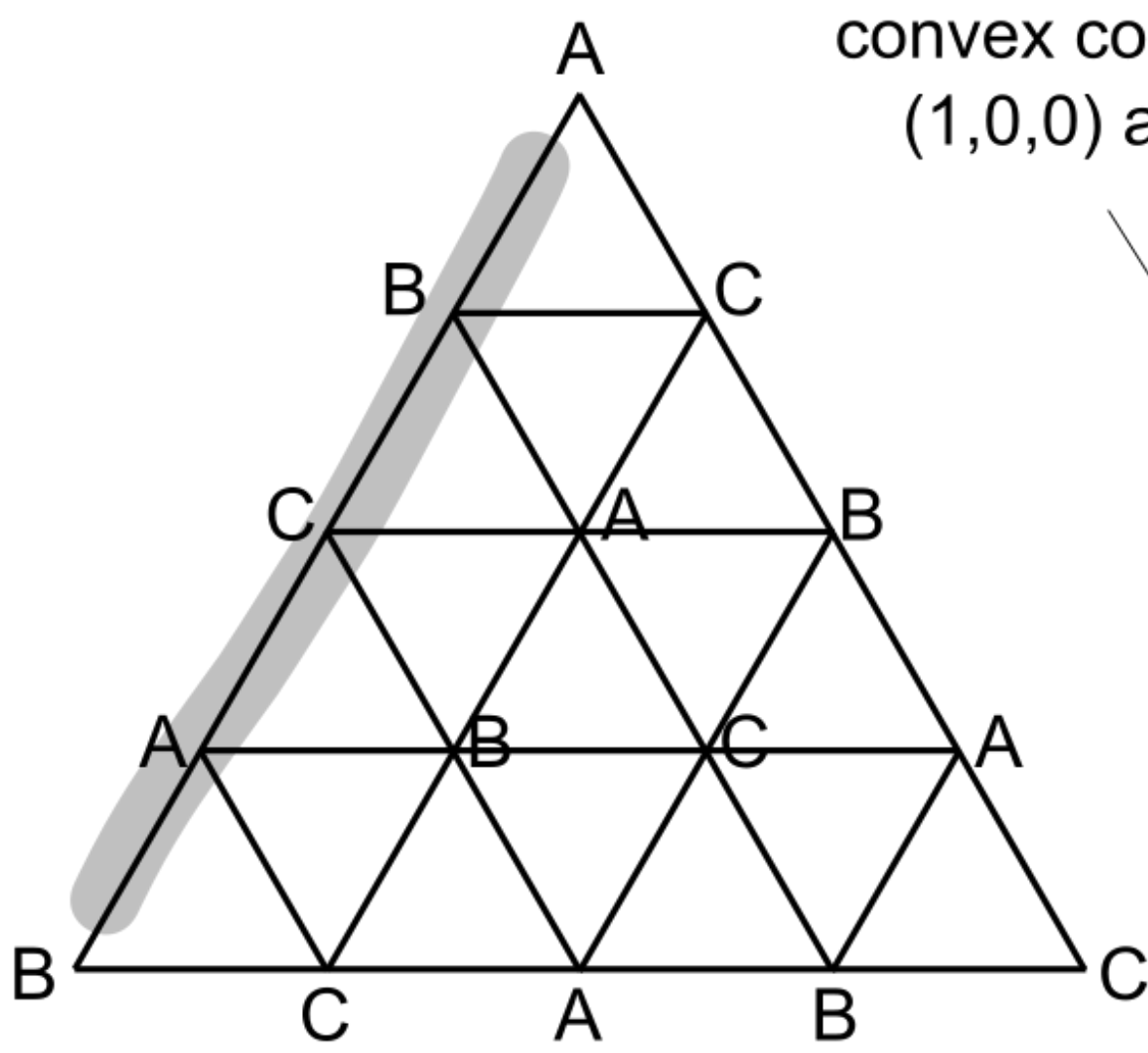

convex combination of
 $(1,0,0)$ and $(0,1,0)$

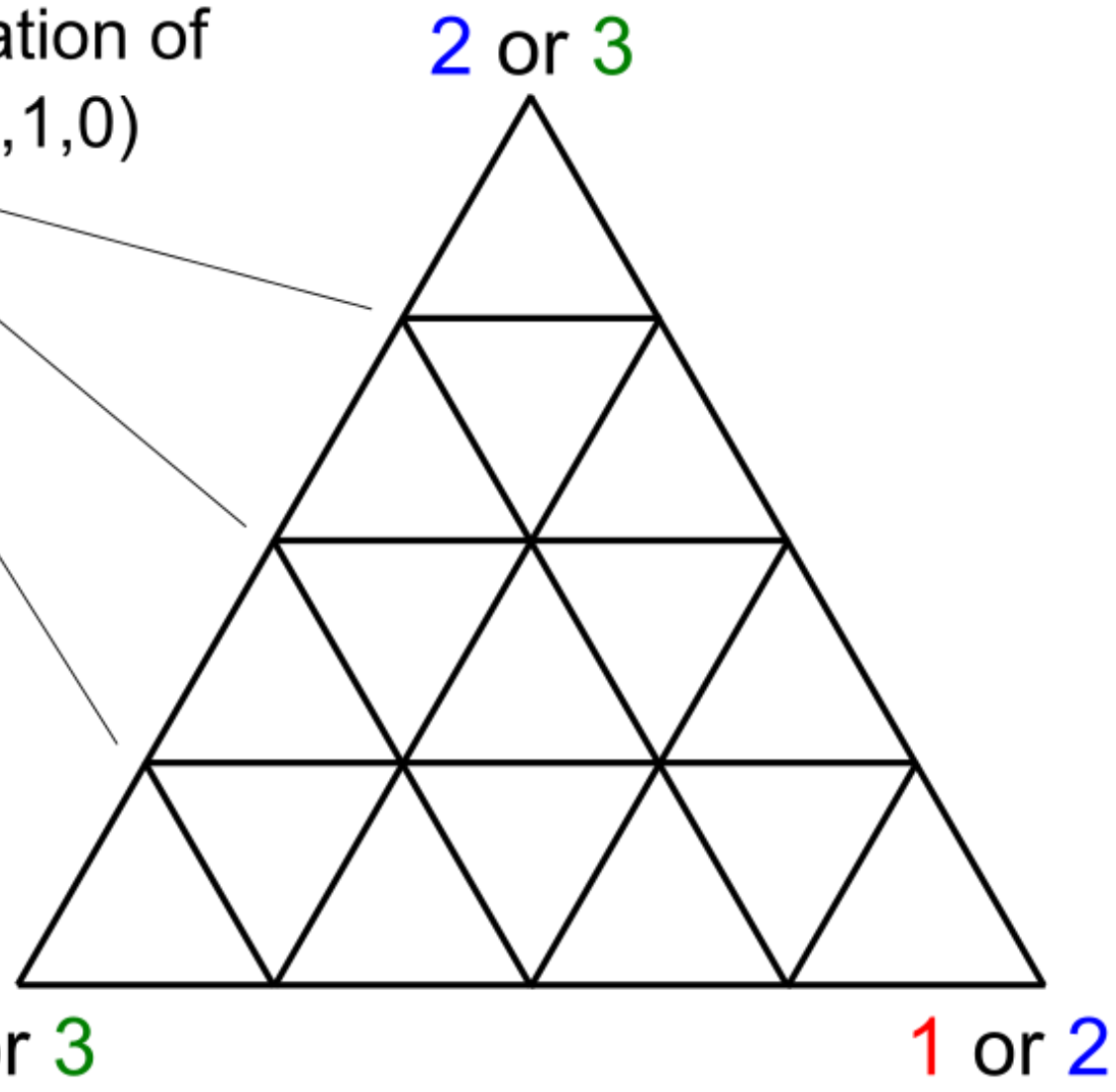

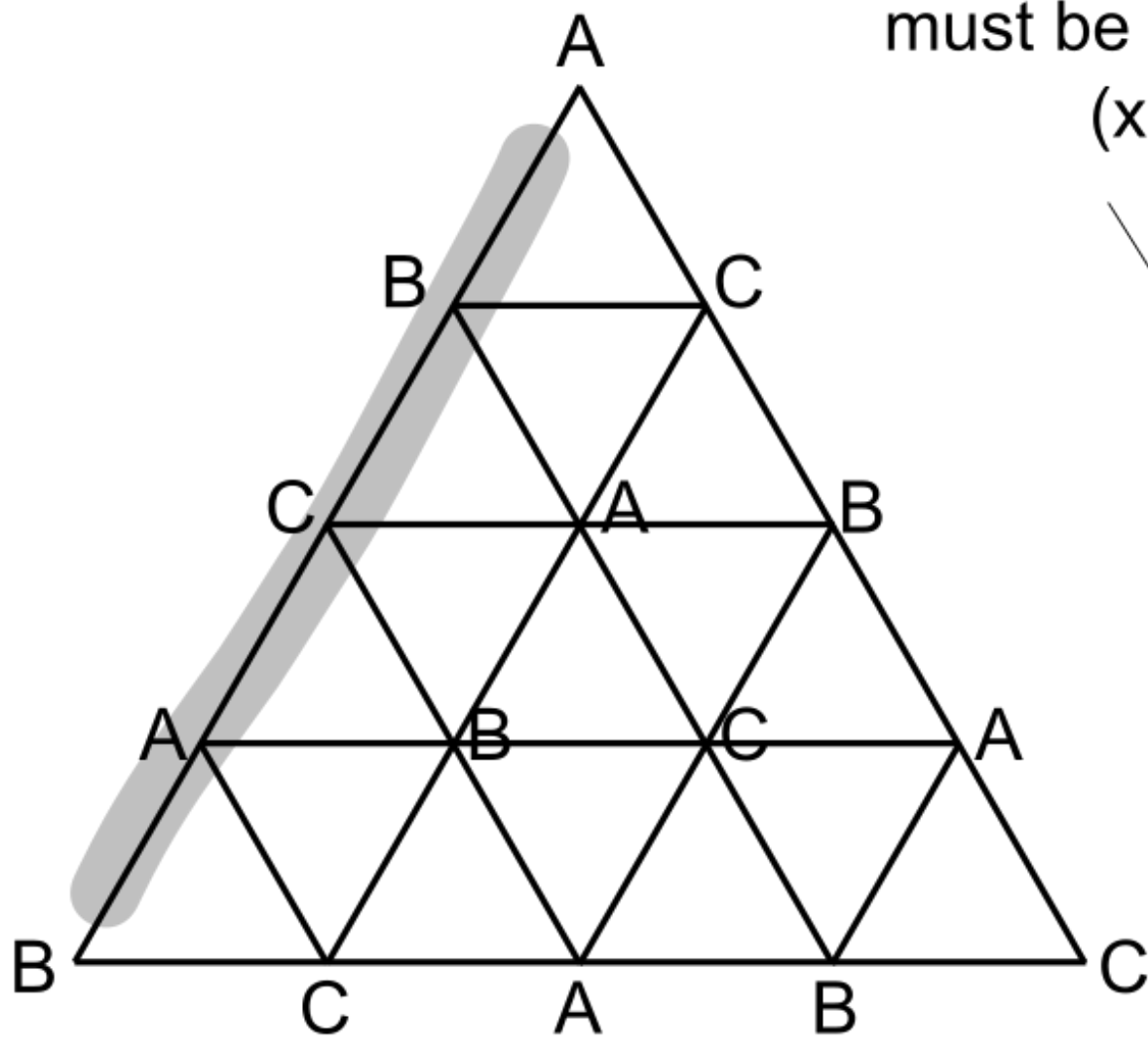

must be of the form
 $(x,y,0)$

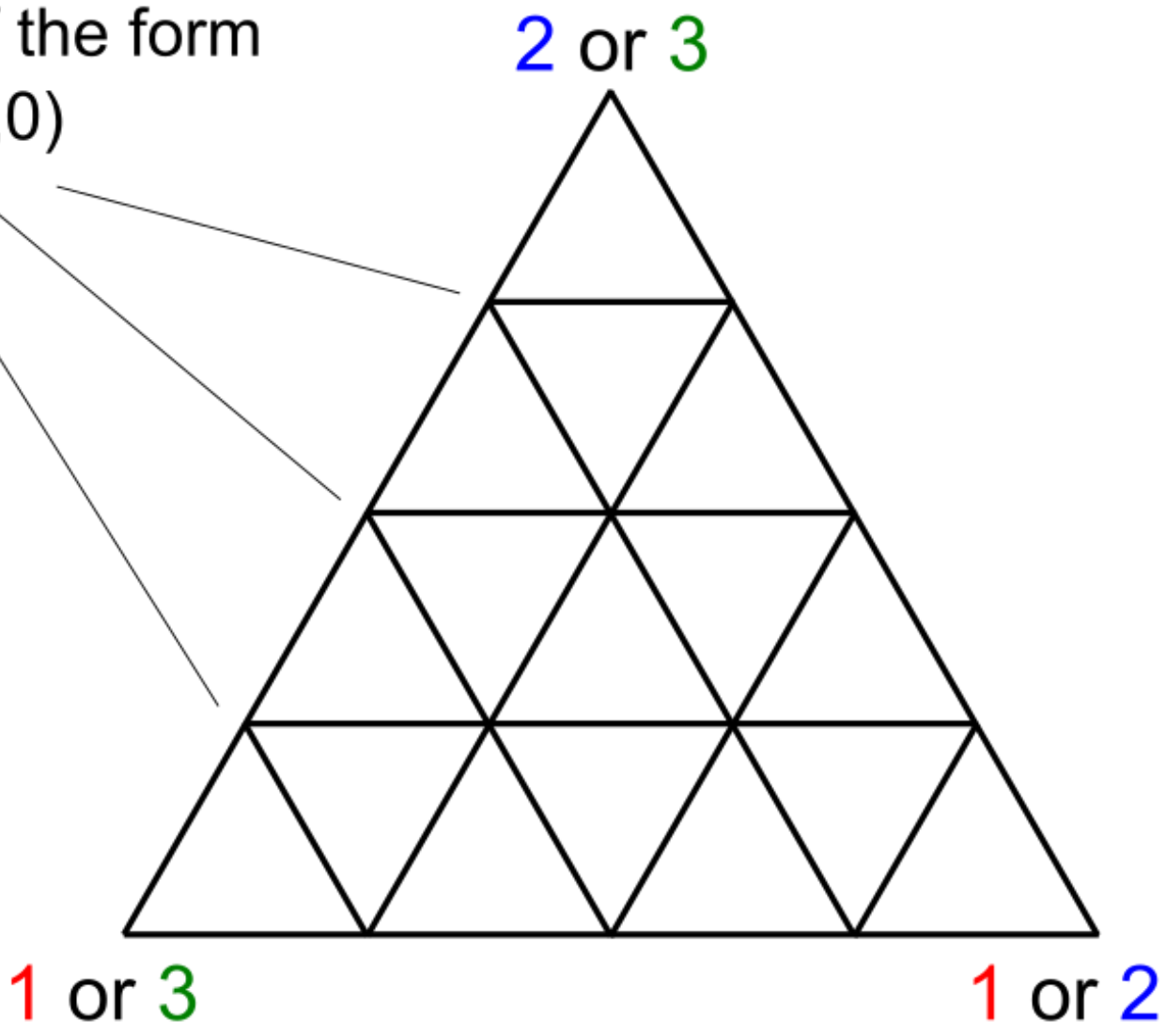

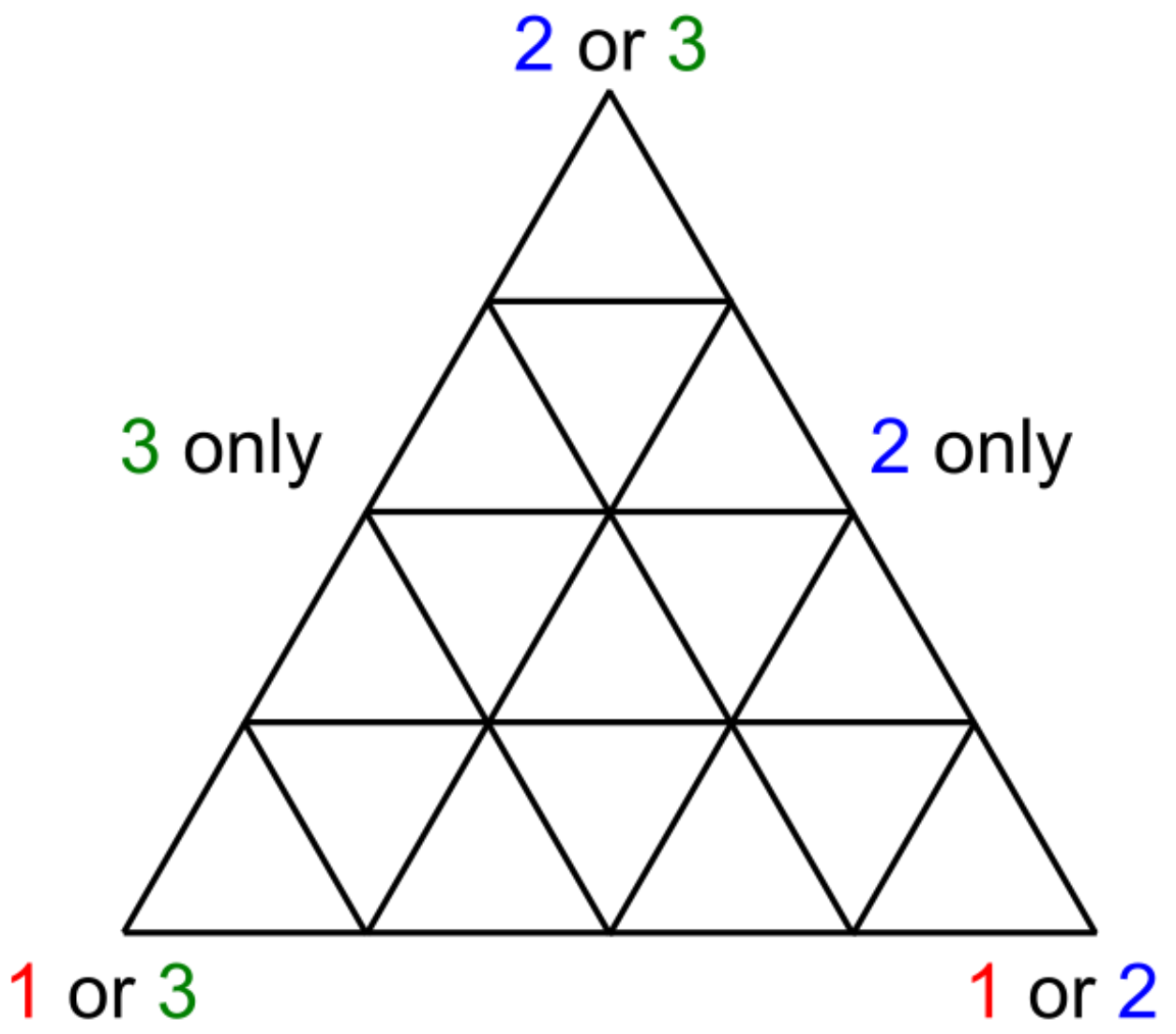
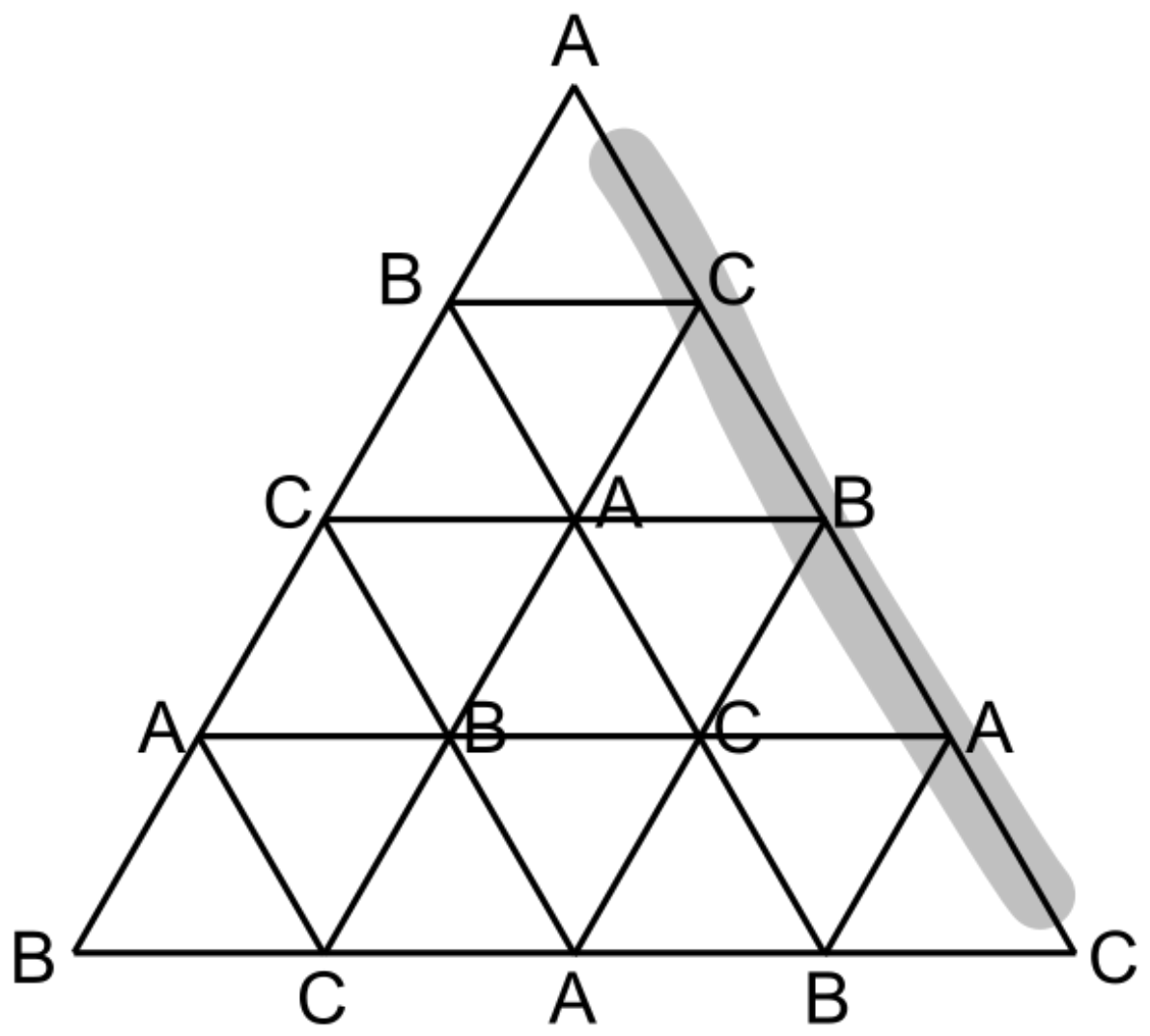

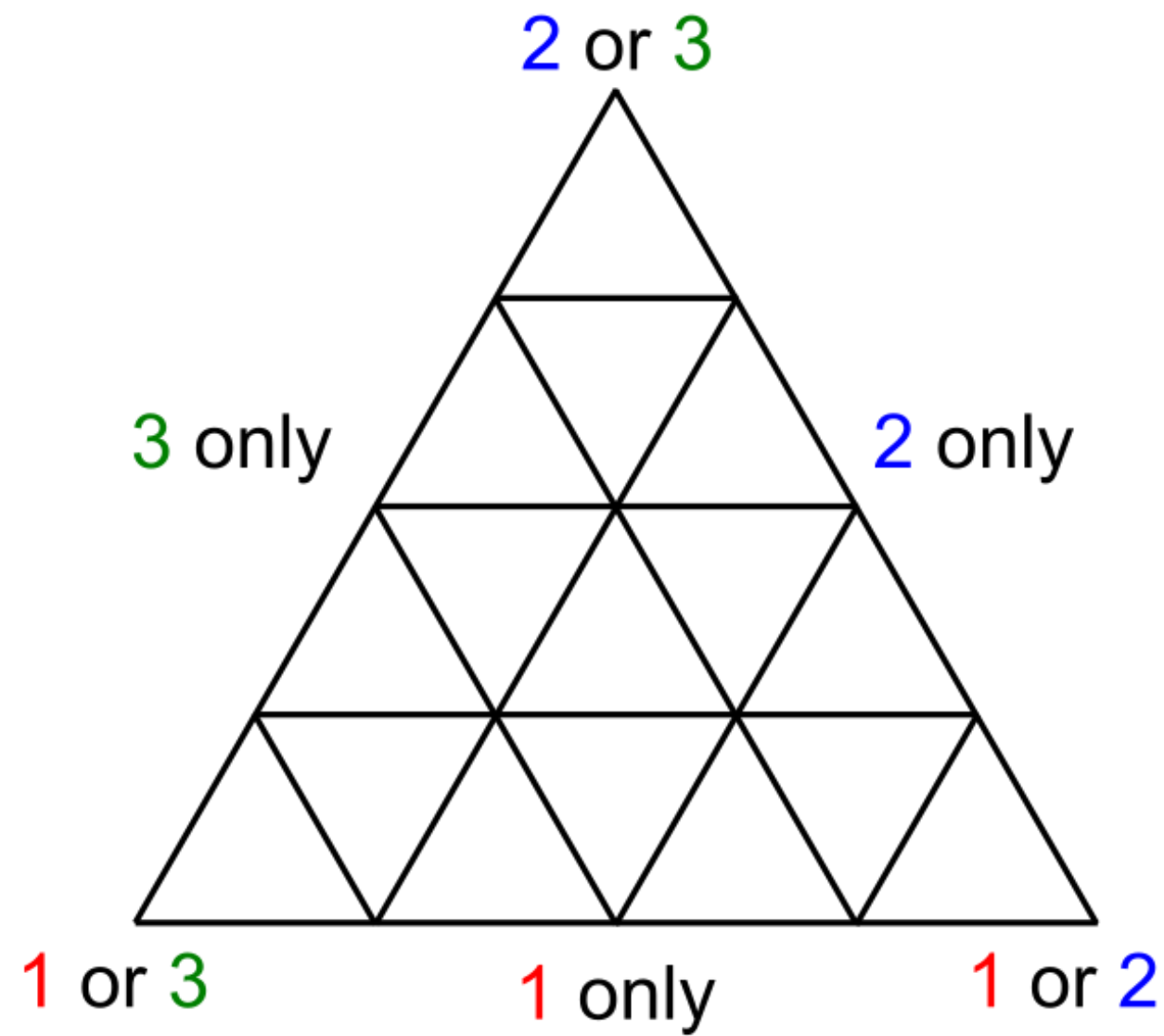
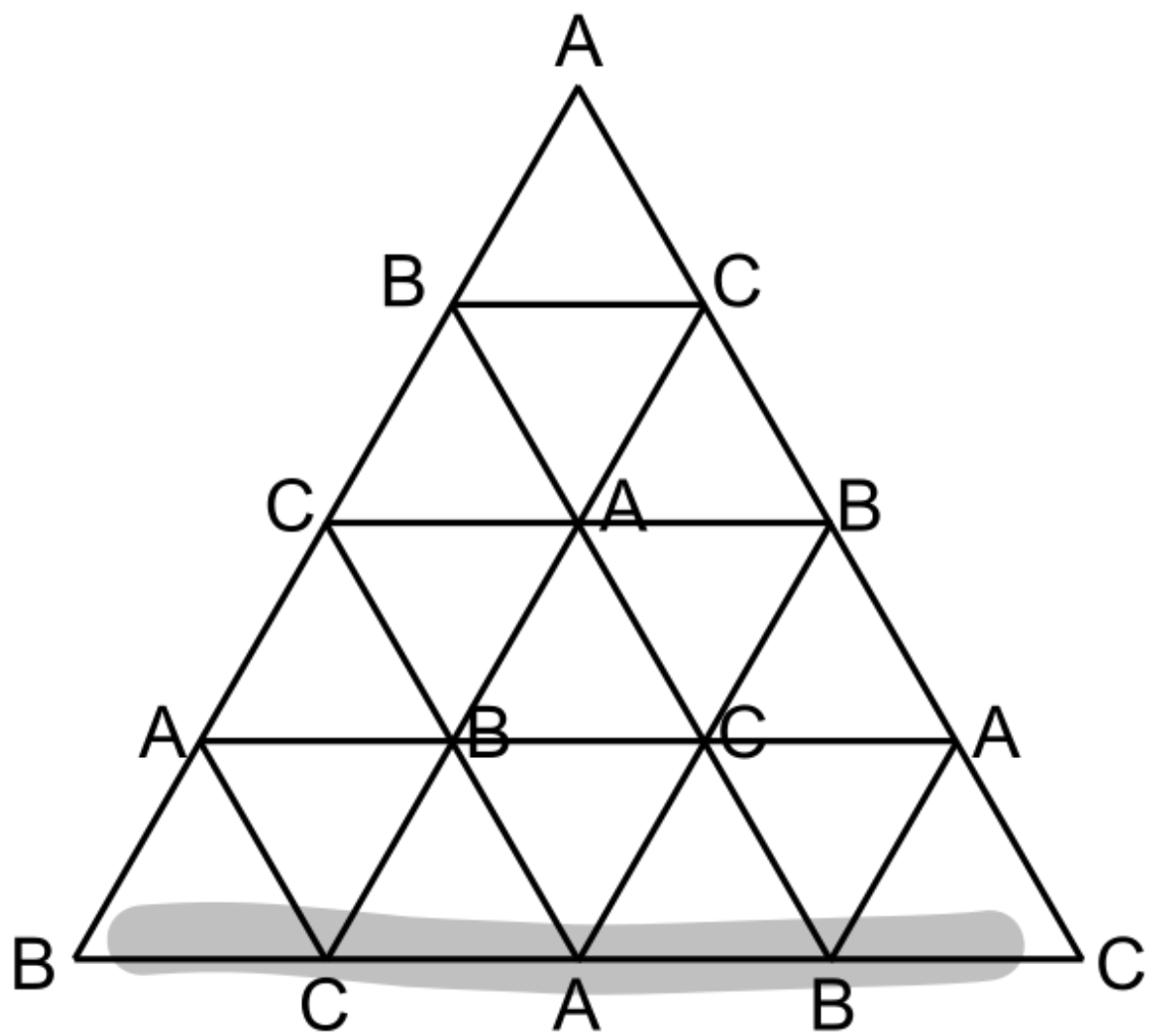

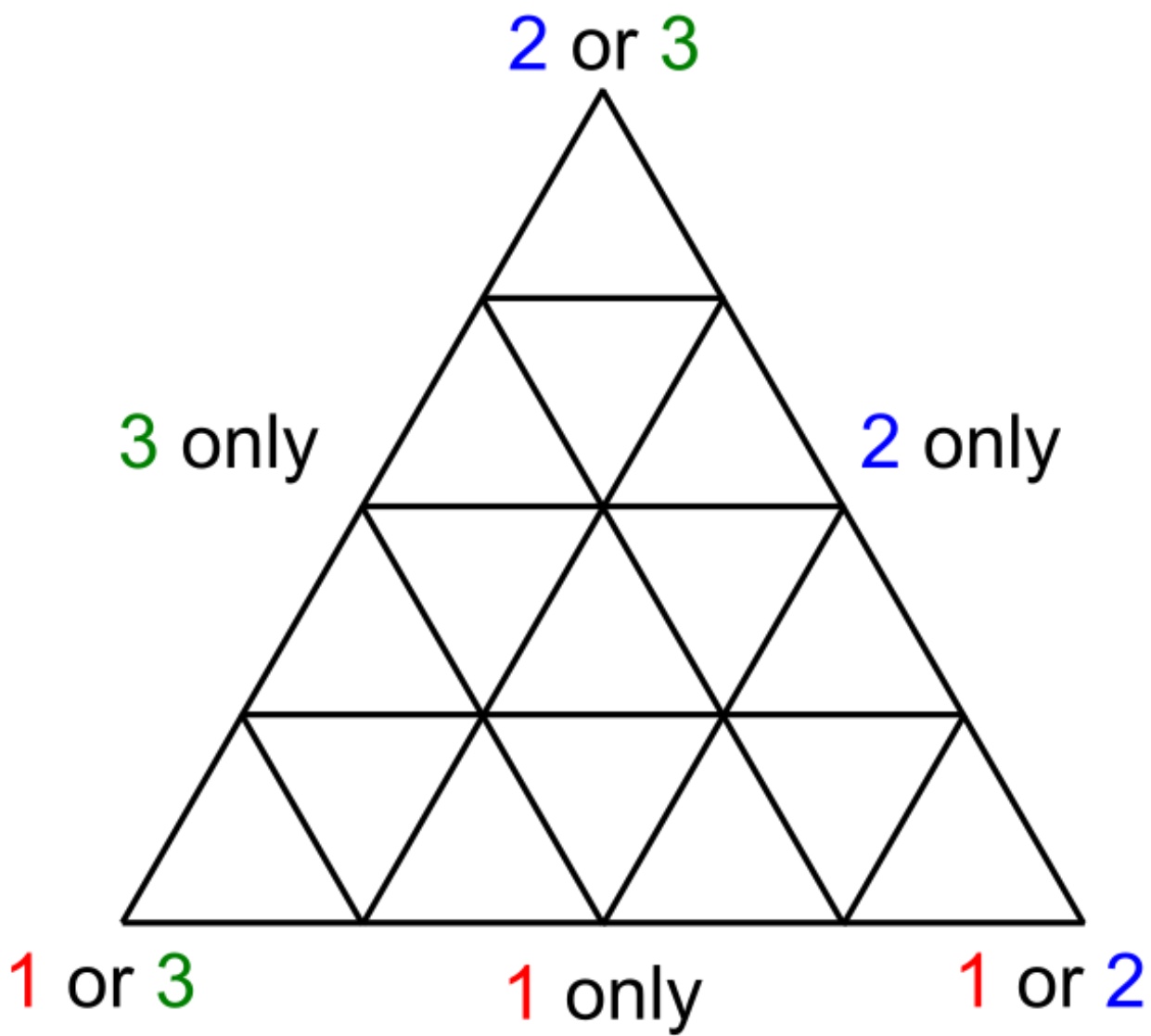
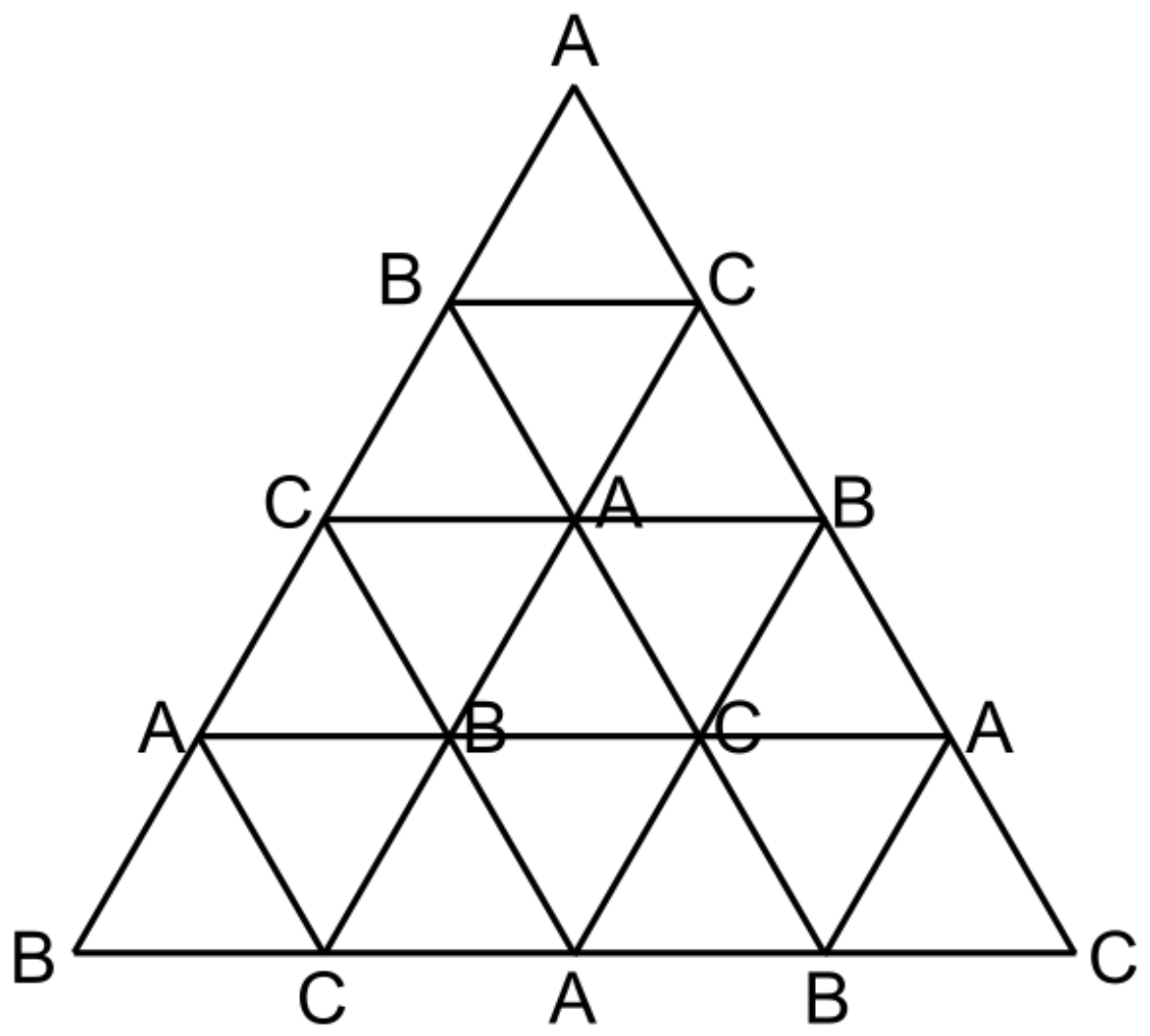

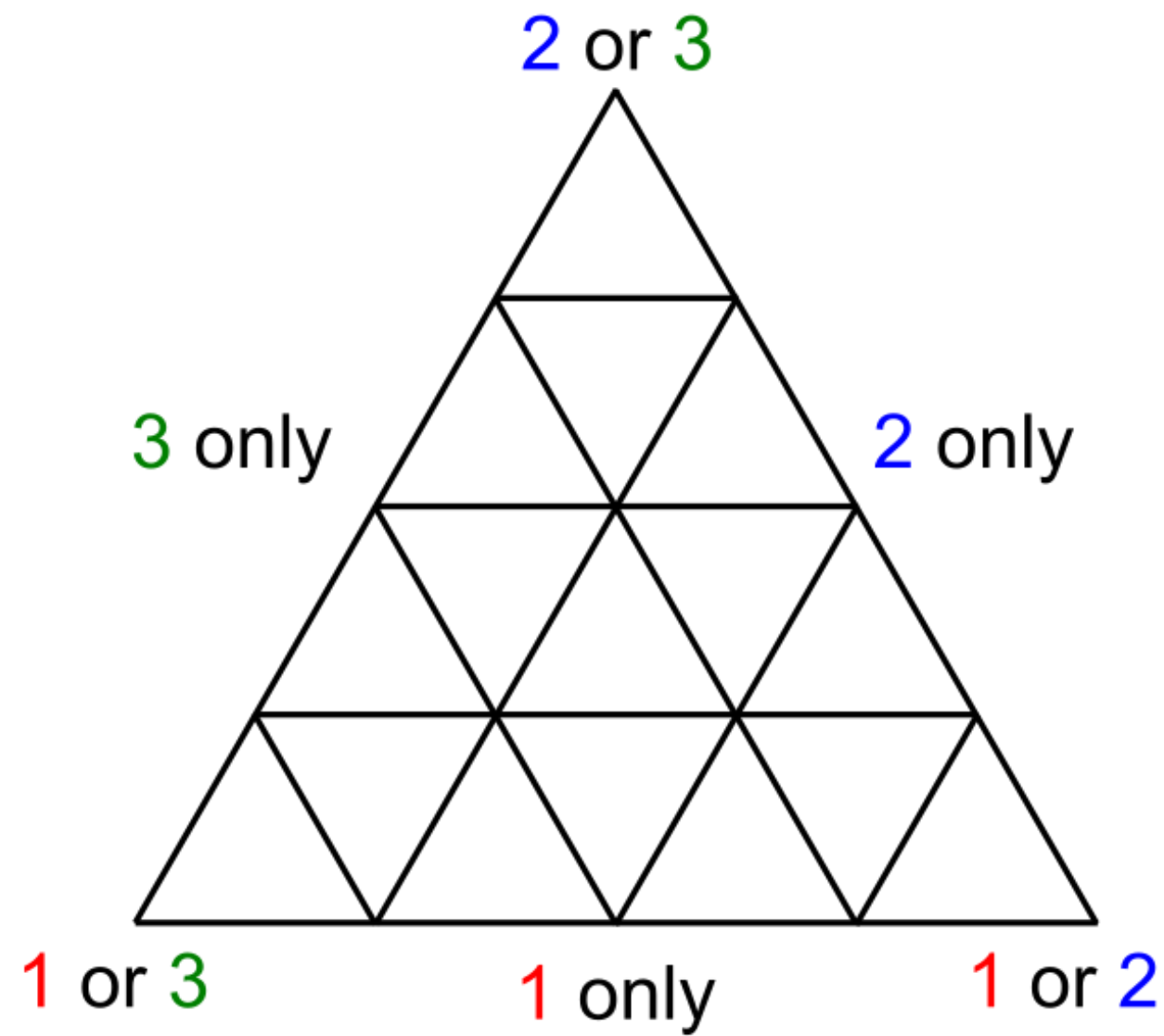

This looks nothing like Sperner.

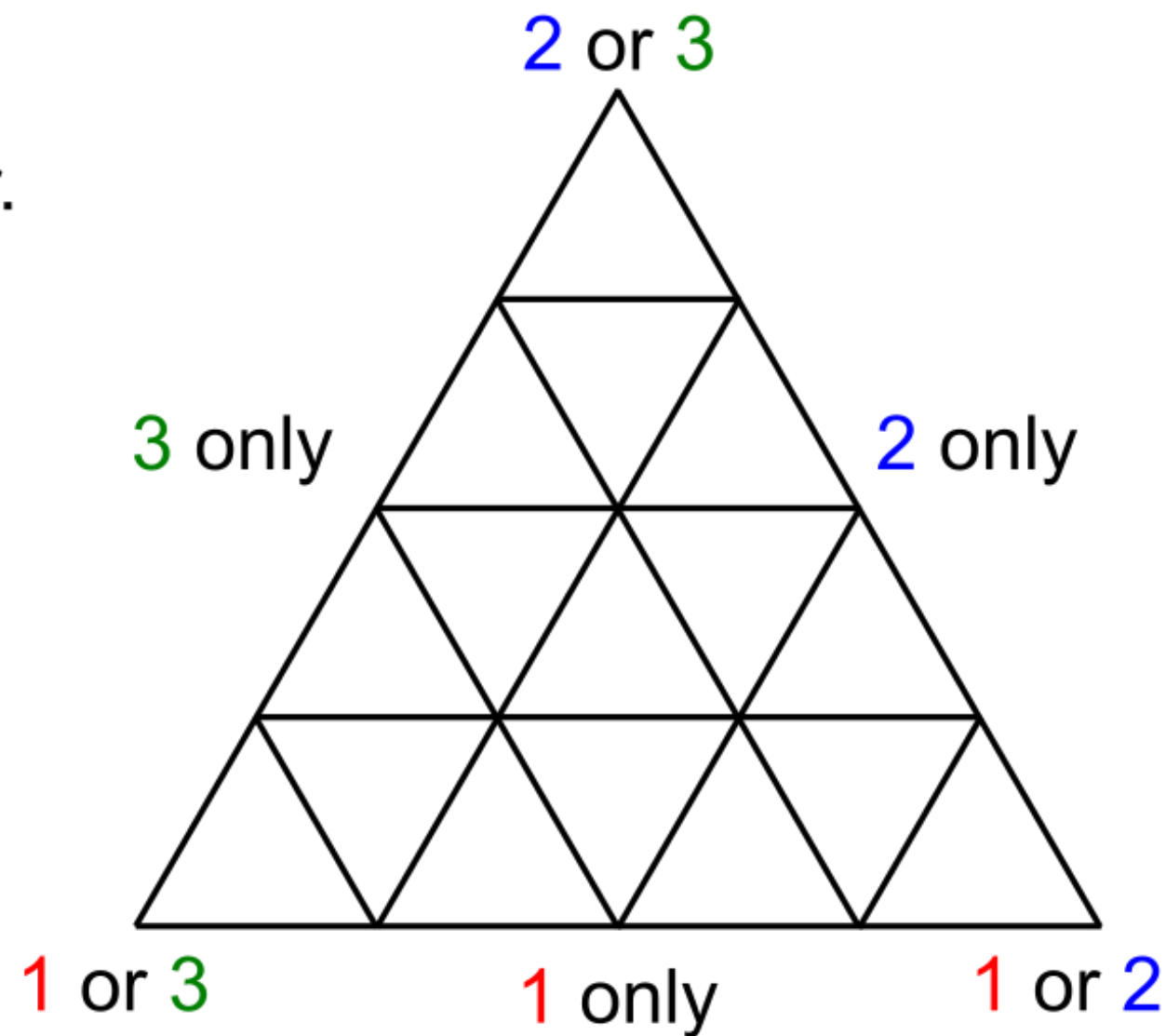

This looks nothing like Sperner.

Why is a fully labeled triangle useful for envy-free rent division?

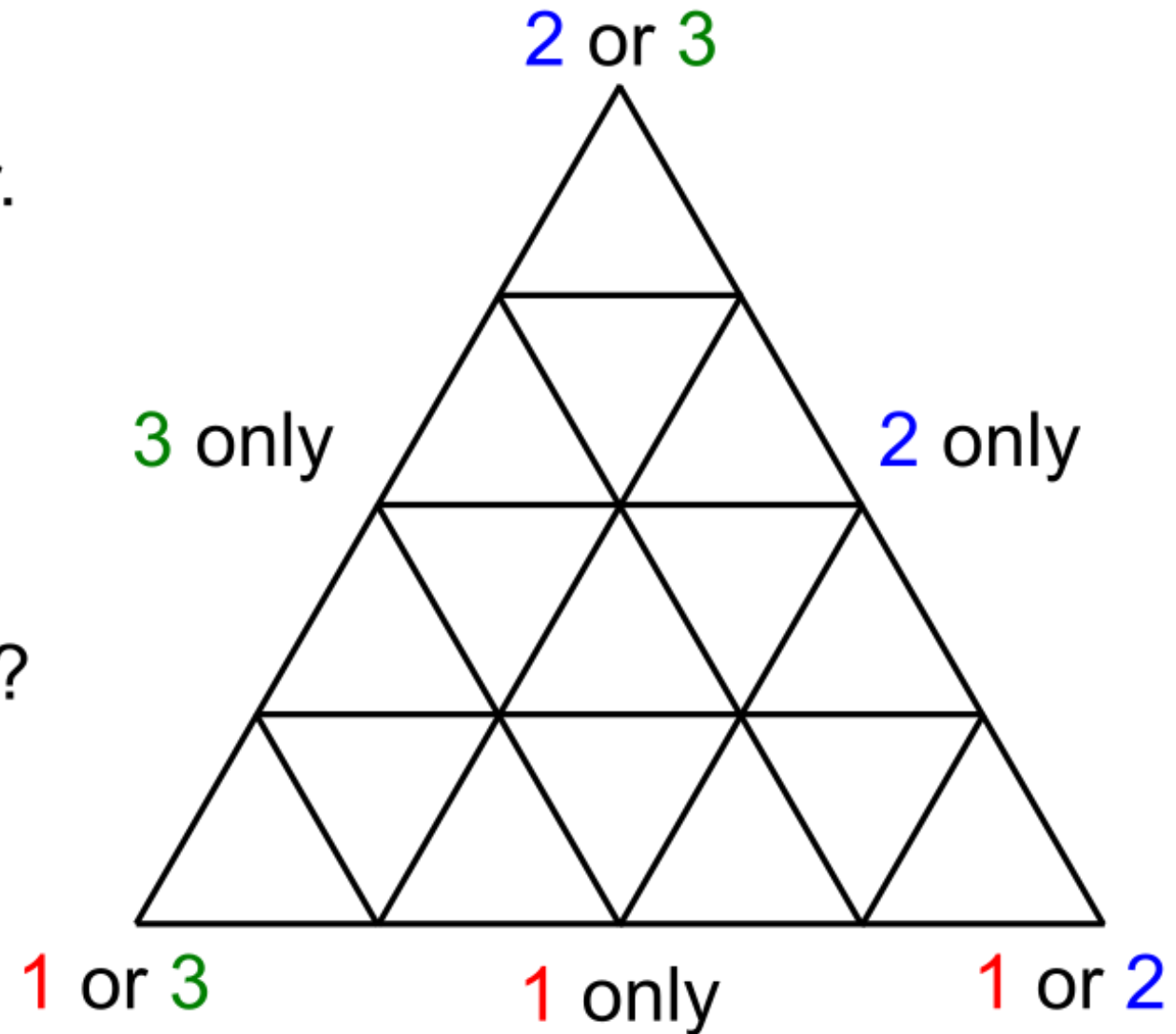

This looks nothing like Sperner.

Why is a fully labeled triangle useful for envy-free rent division?

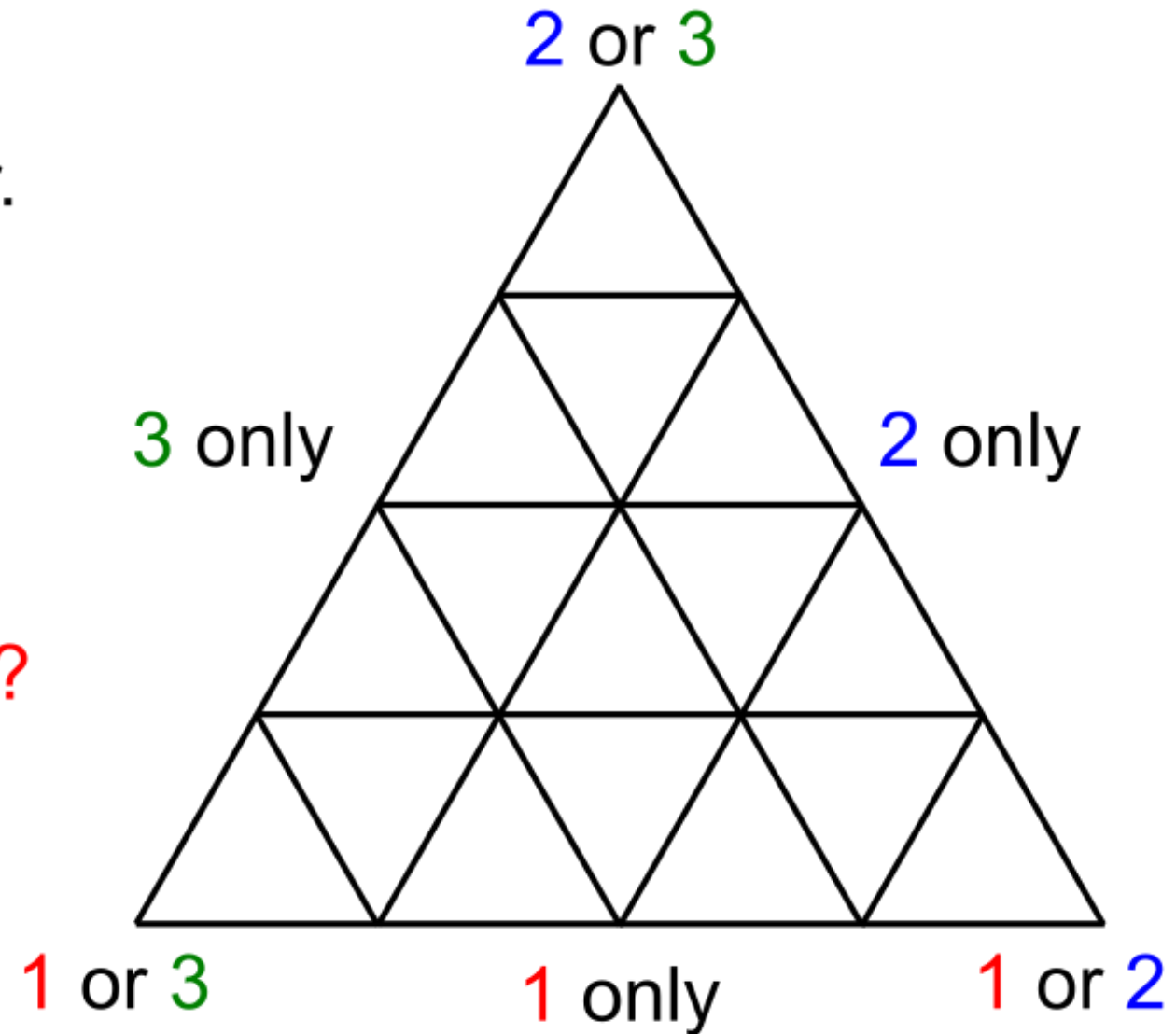

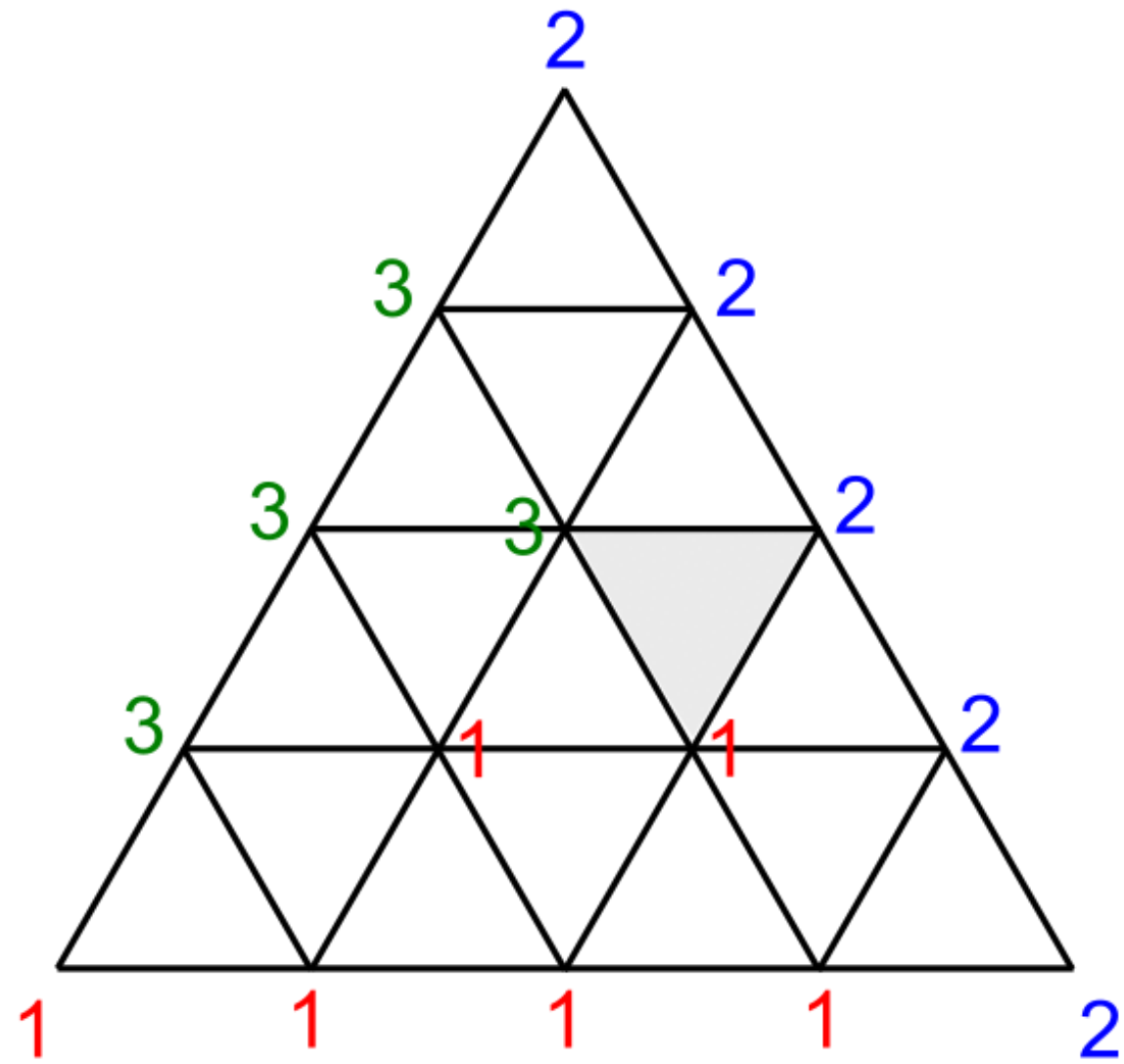

a set of three "nearby"
pricing schemes at which
different agents prefer
different rooms

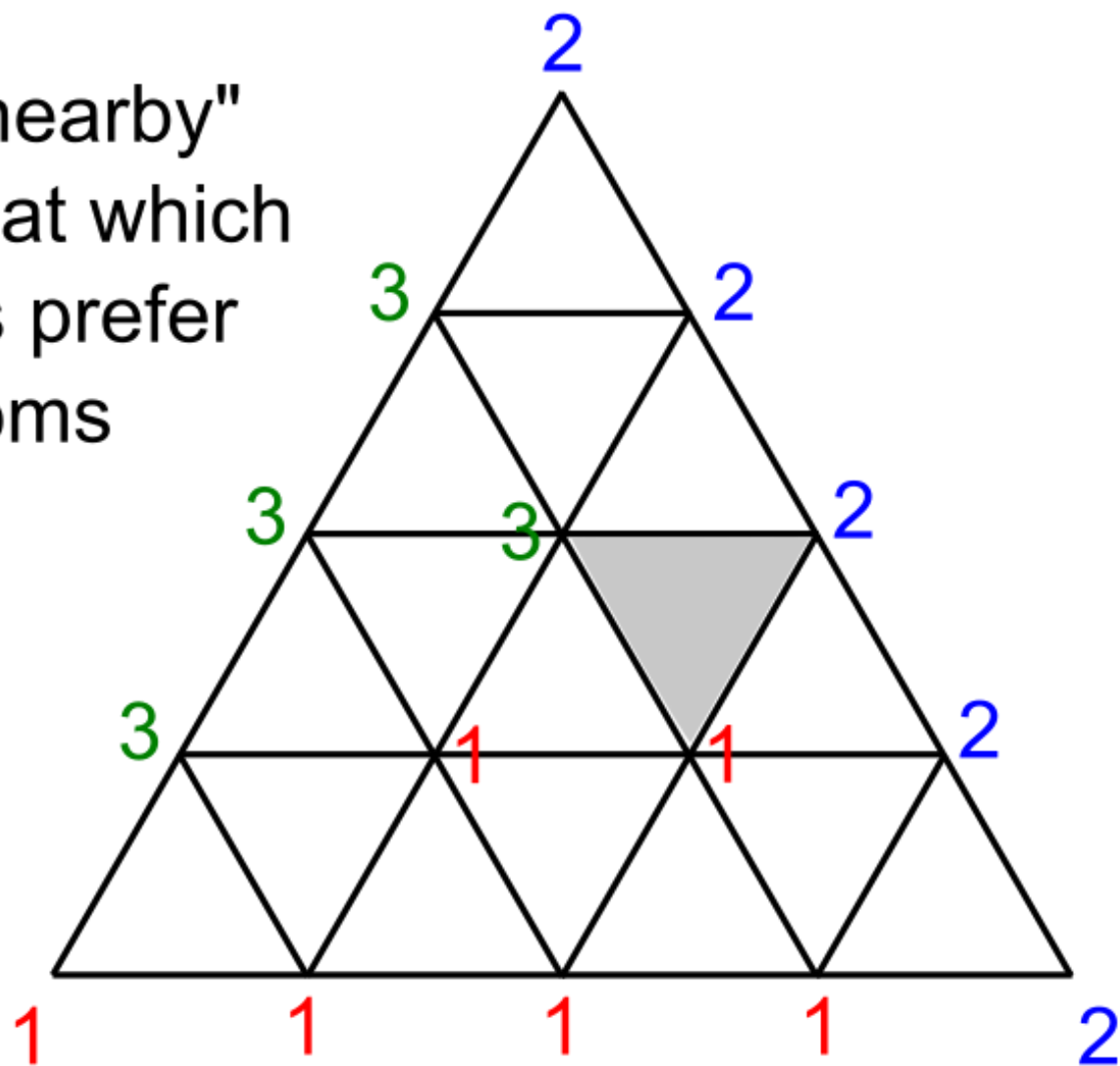

a set of three "nearby"
pricing schemes at which
different agents prefer
different rooms

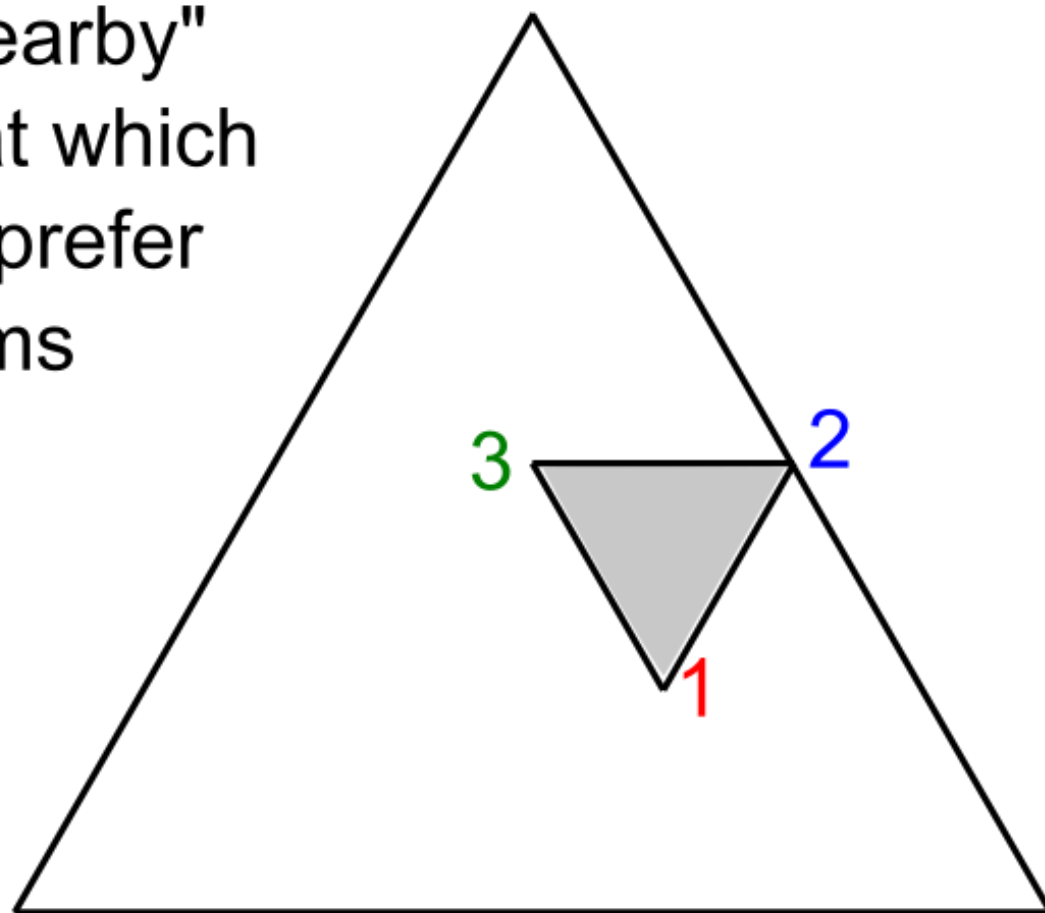

a set of three "nearby"
pricing schemes at which
different agents prefer
different rooms

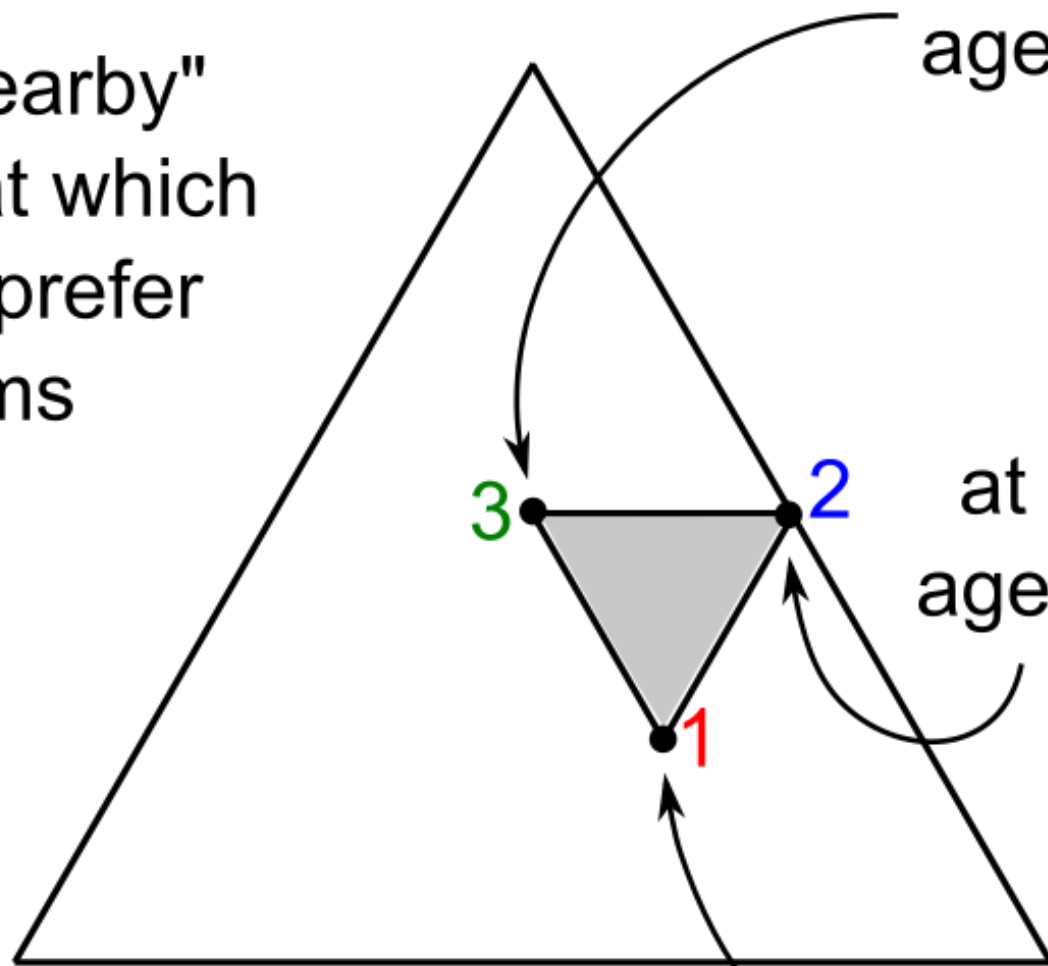

at prices (500,250,250)
agent A prefers room 3

at prices (500,0,500)
agent B prefers room 2

at prices (250,250,500)
agent C prefers room 1

a set of three "nearby"
pricing schemes at which
different agents prefer
different rooms

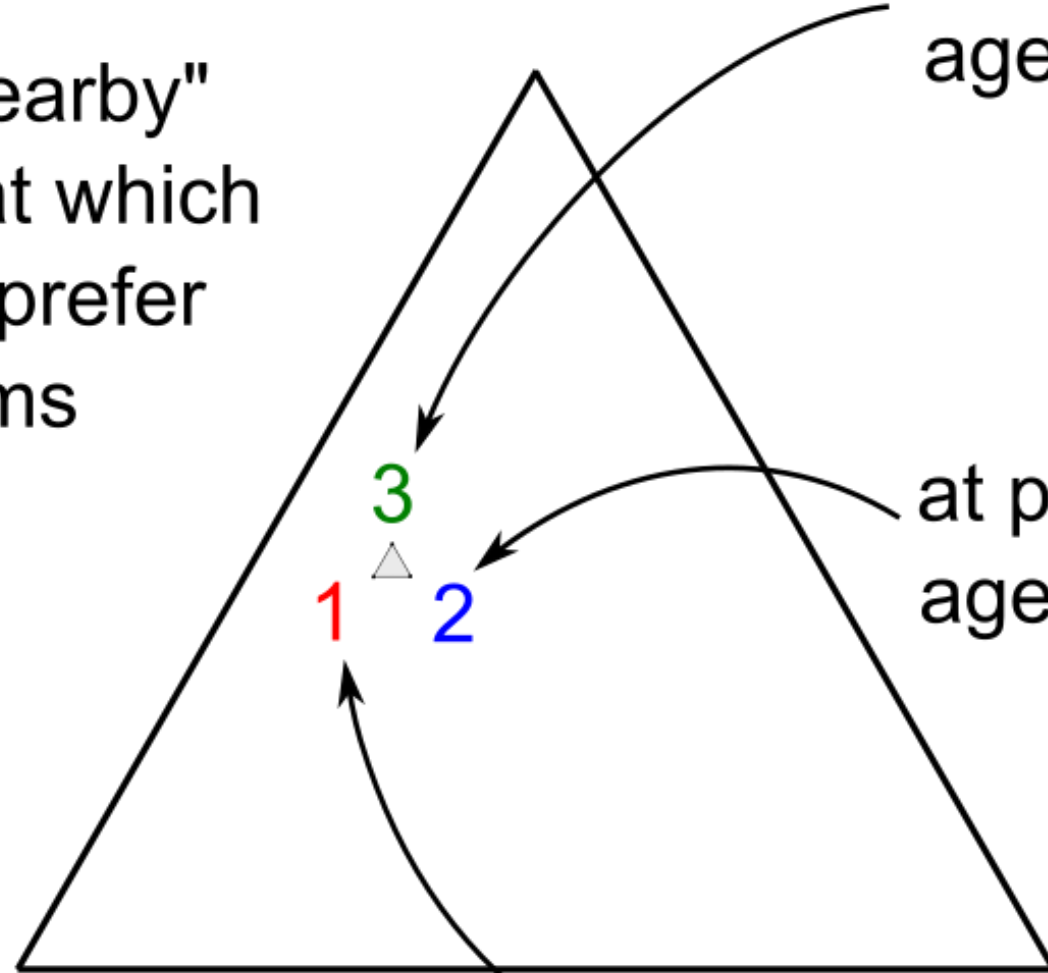

at prices (426, 424, 150)
agent A prefers room 3

at prices (425, 424, 151)
agent B prefers room 2

at prices (425, 425, 150)
agent C prefers room 1

Approx. envy-free rent division
(up to a rupee)

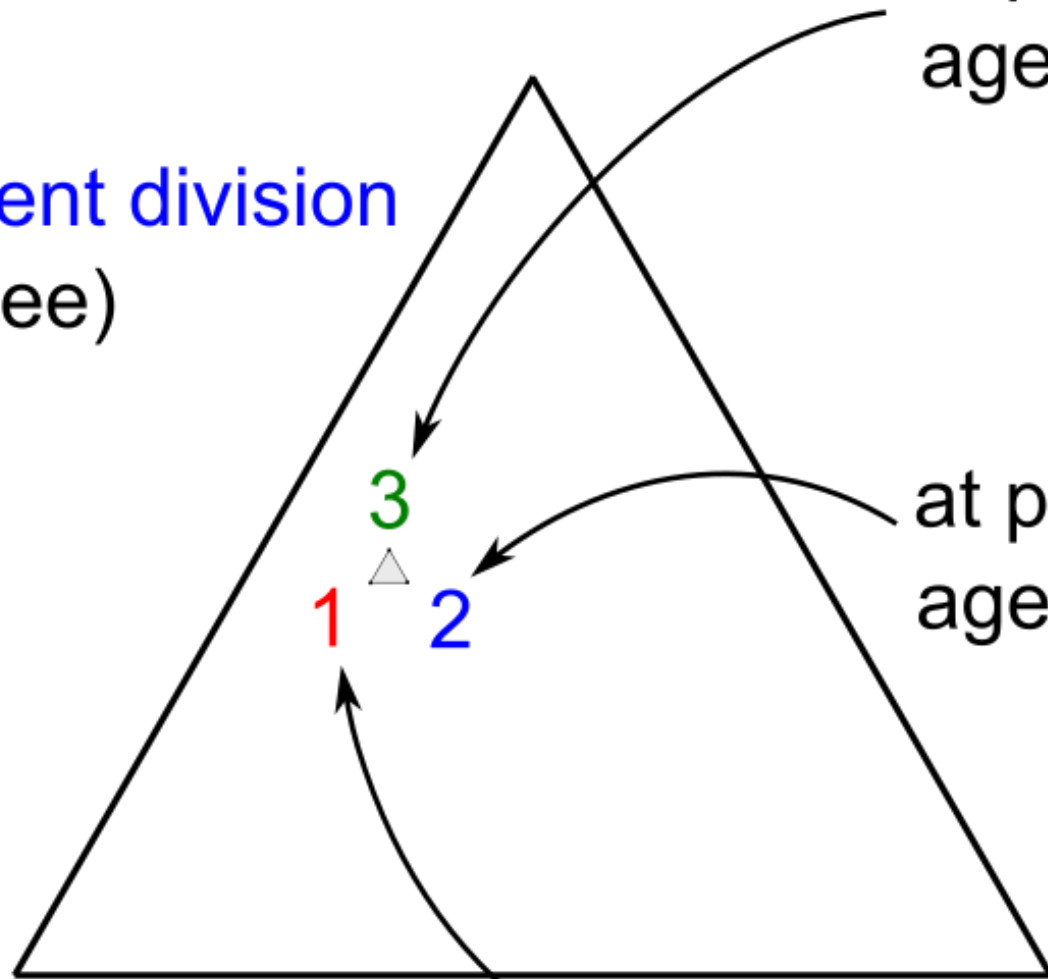

at prices (426, 424, 150)
agent A prefers room 3

at prices (425, 424, 151)
agent B prefers room 2

at prices (425, 425, 150)
agent C prefers room 1

This looks nothing like Sperner.

Why is a fully labeled triangle useful for envy-free rent division?

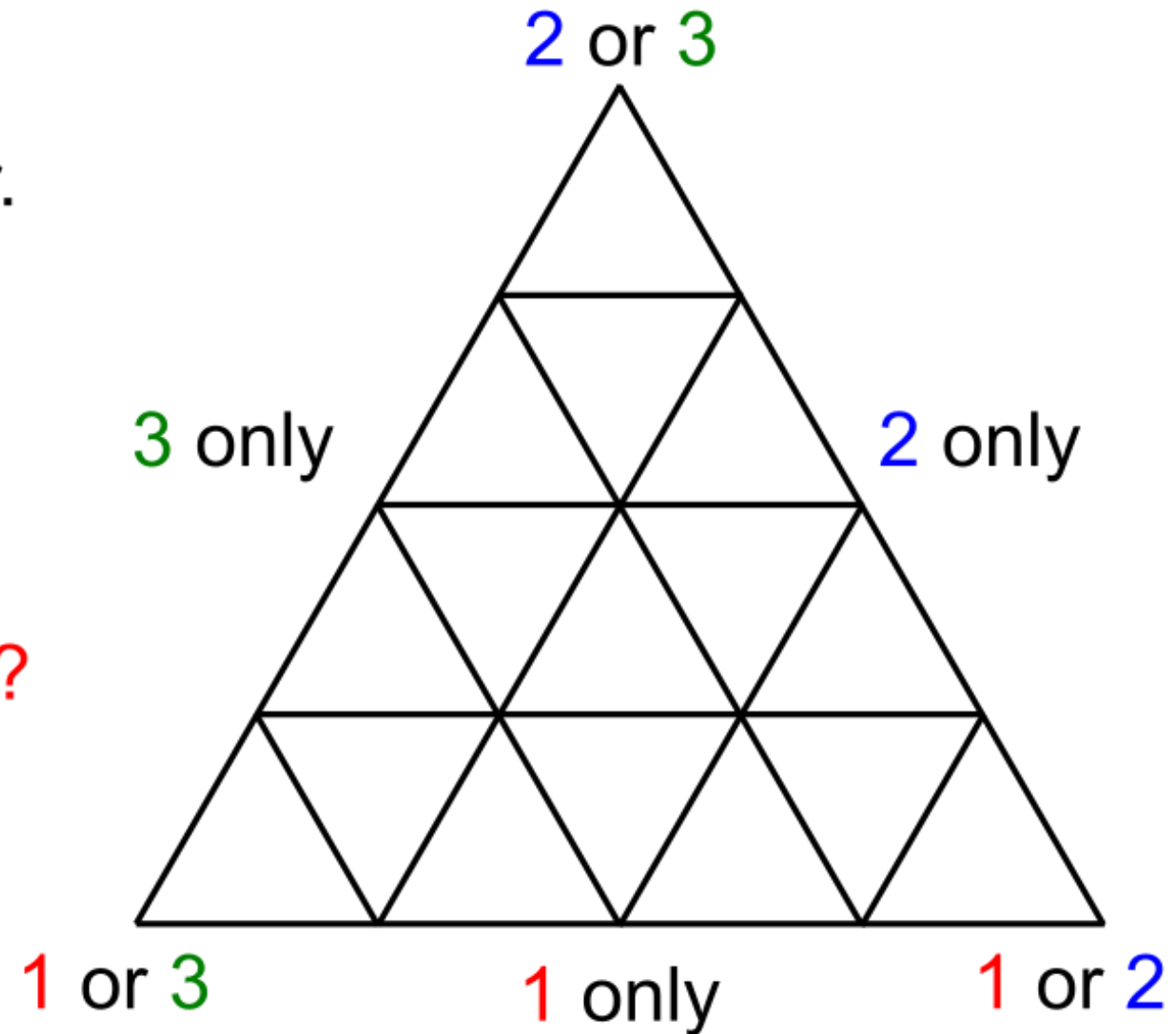

This looks nothing like Sperner.

Why is a fully labeled triangle useful for envy-free rent division?

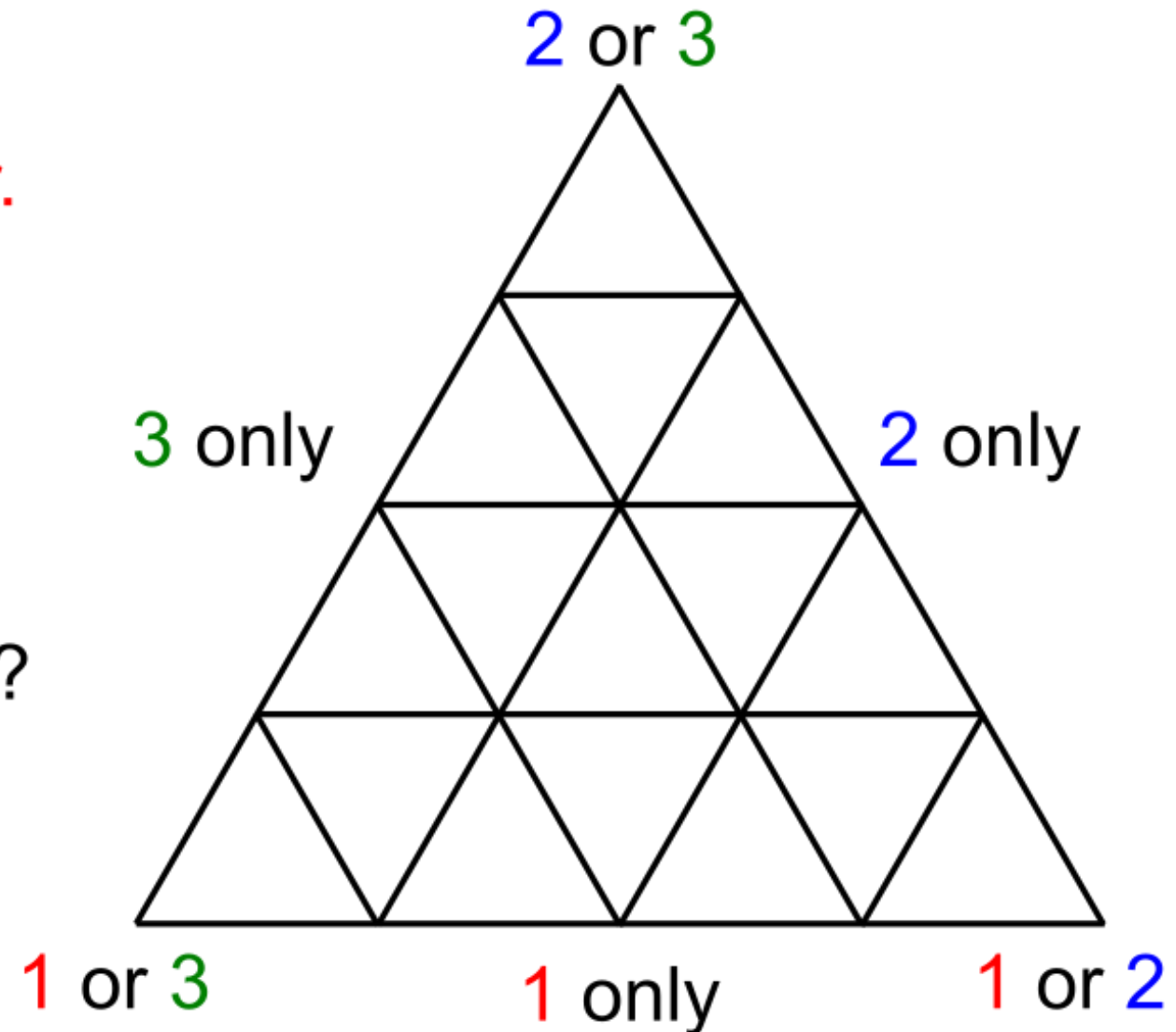

This looks nothing like Sperner.
Think outside the box!

Why is a fully labeled triangle
useful for envy-free rent division?

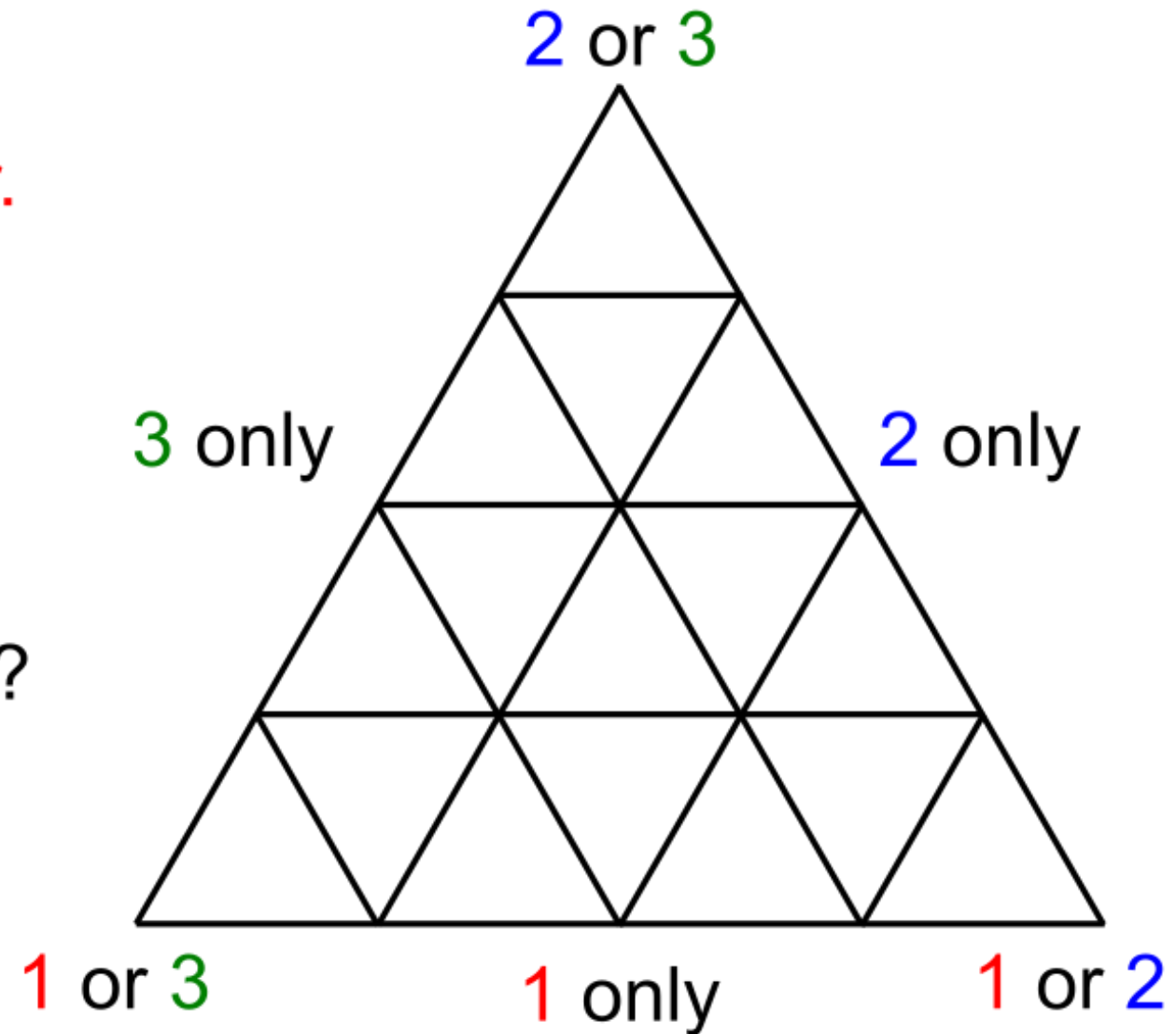

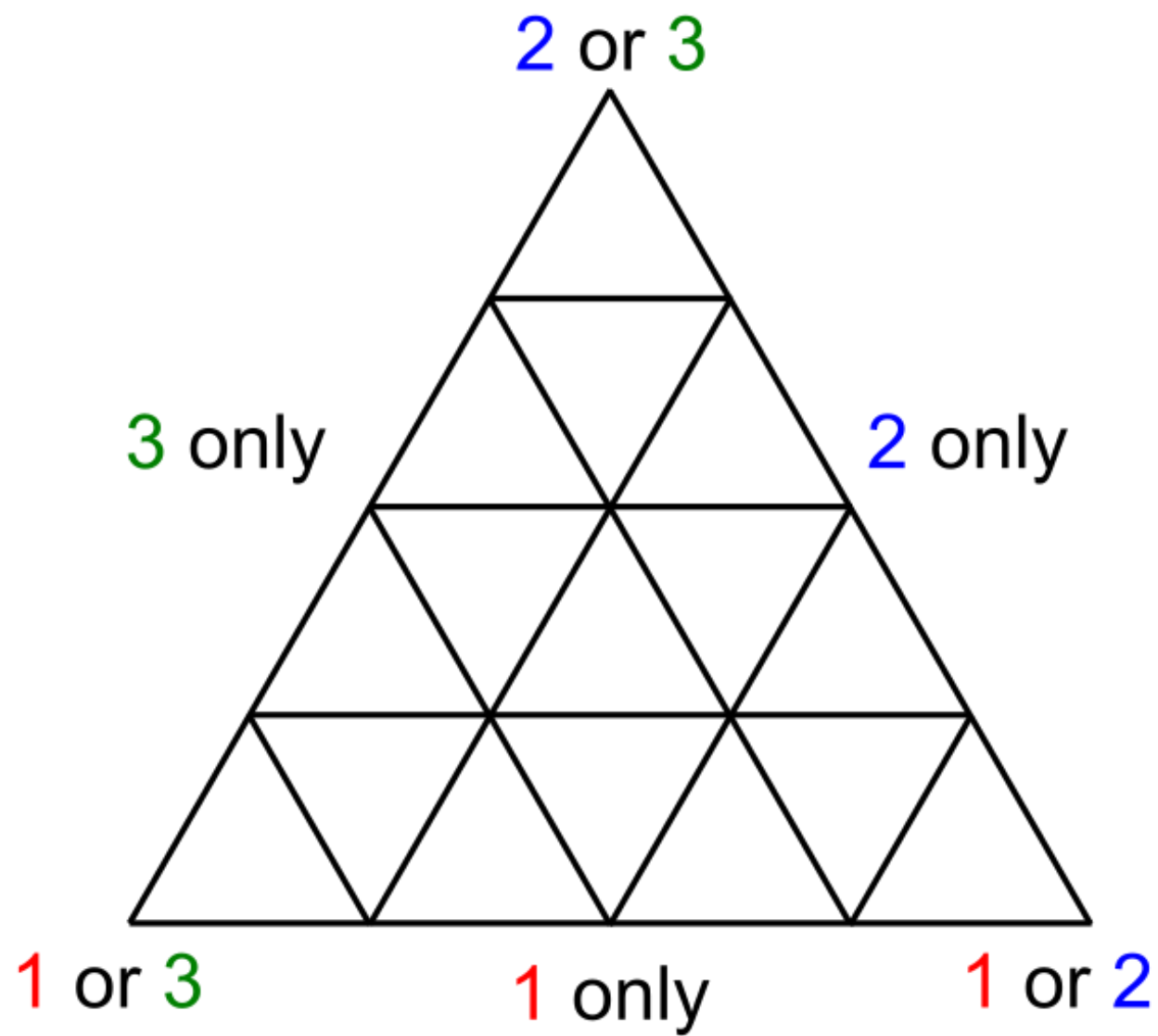

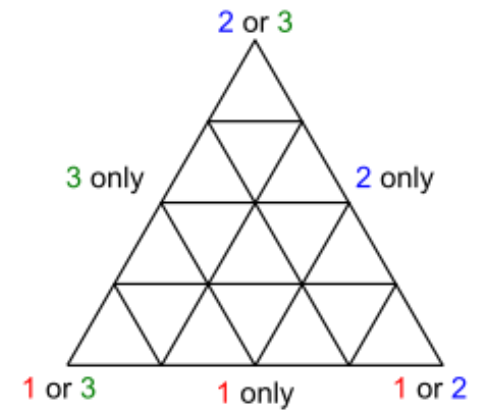

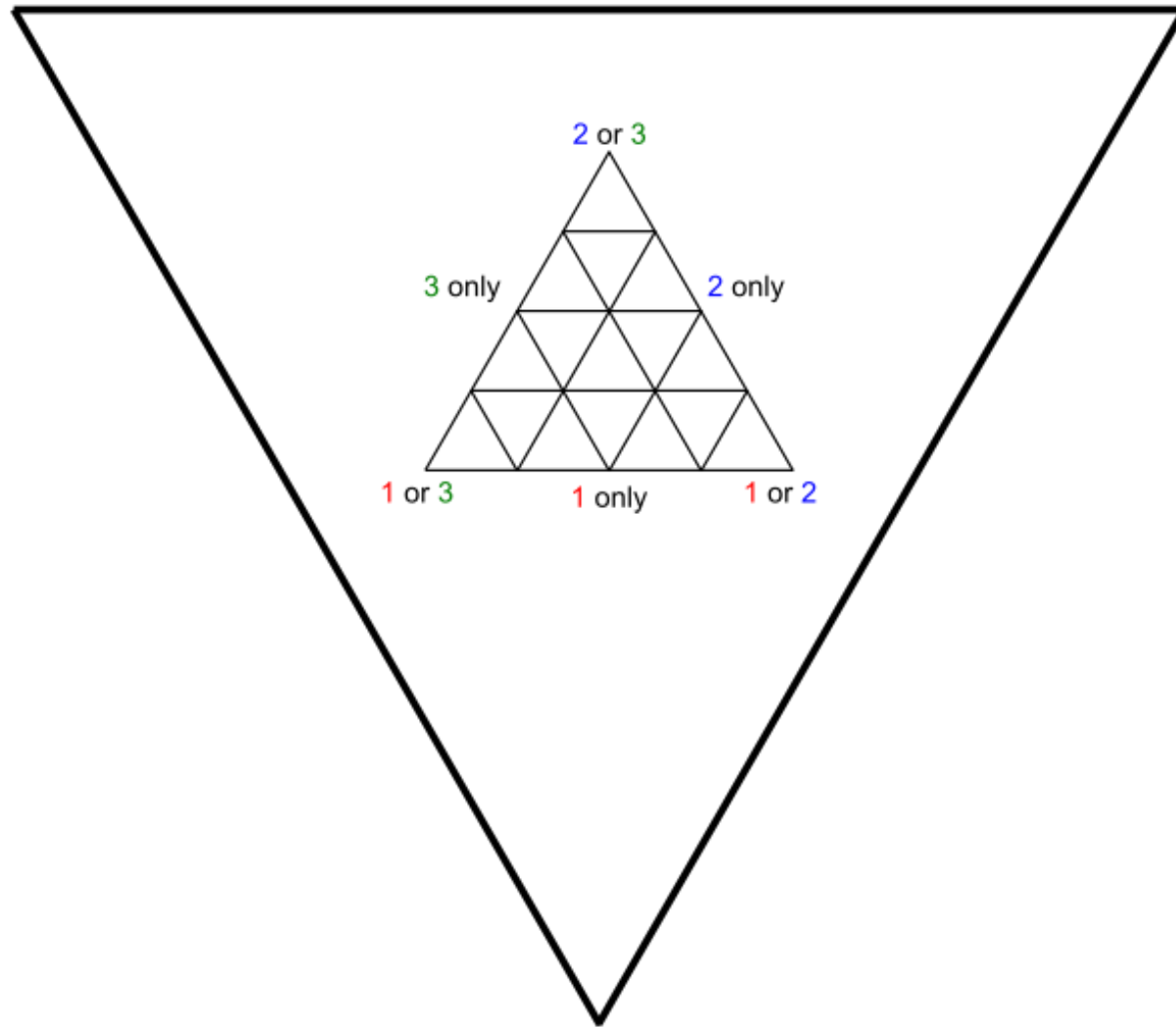

3

2

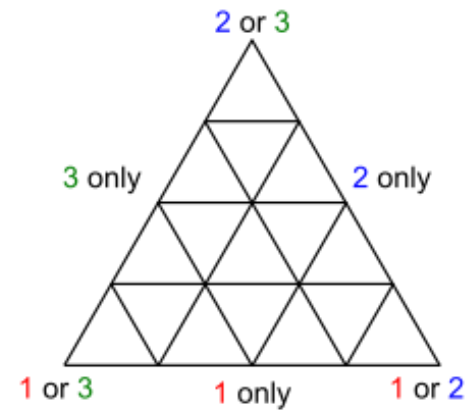

1

3

2

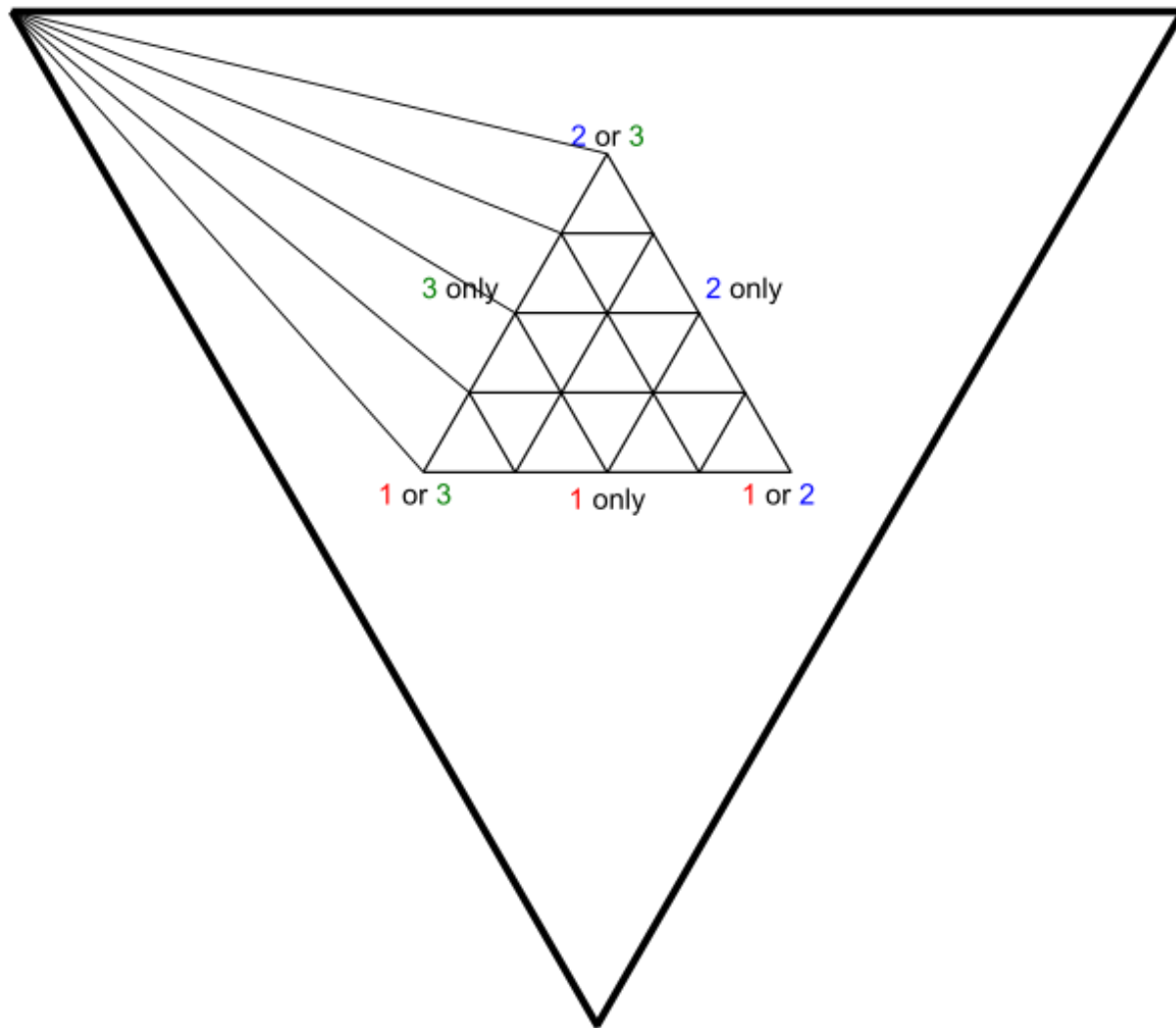

1

3

2

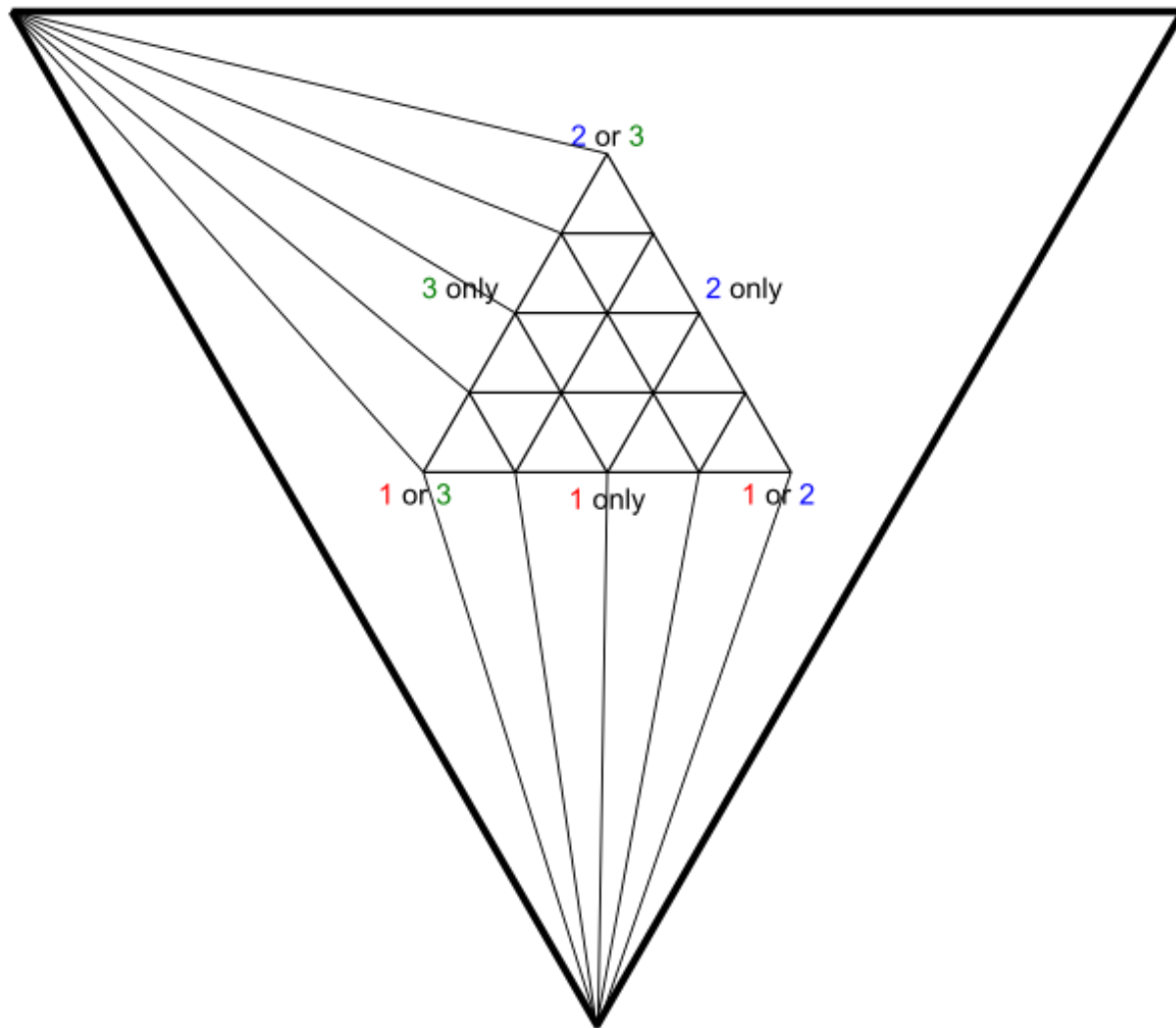

1

3

2

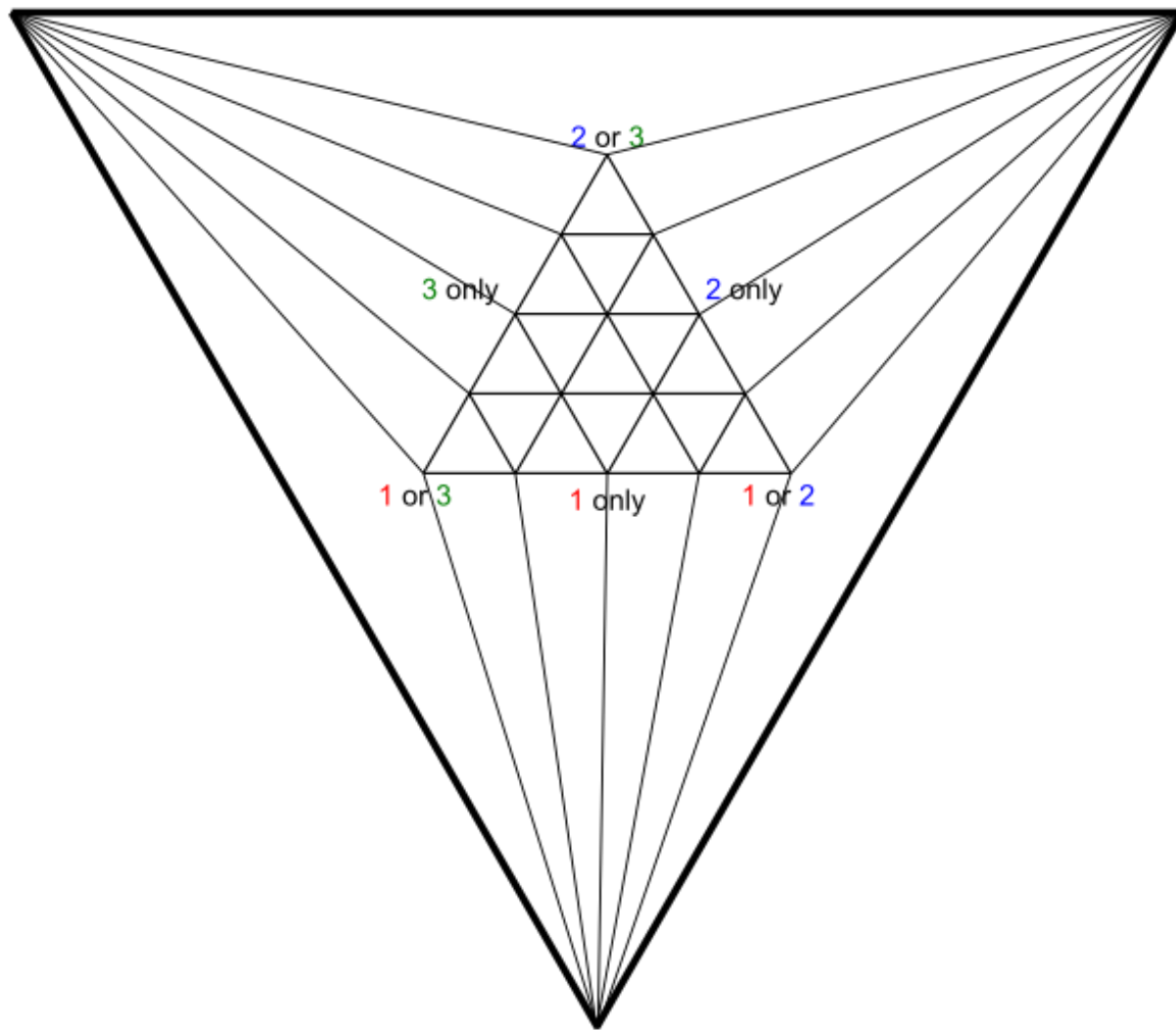

1

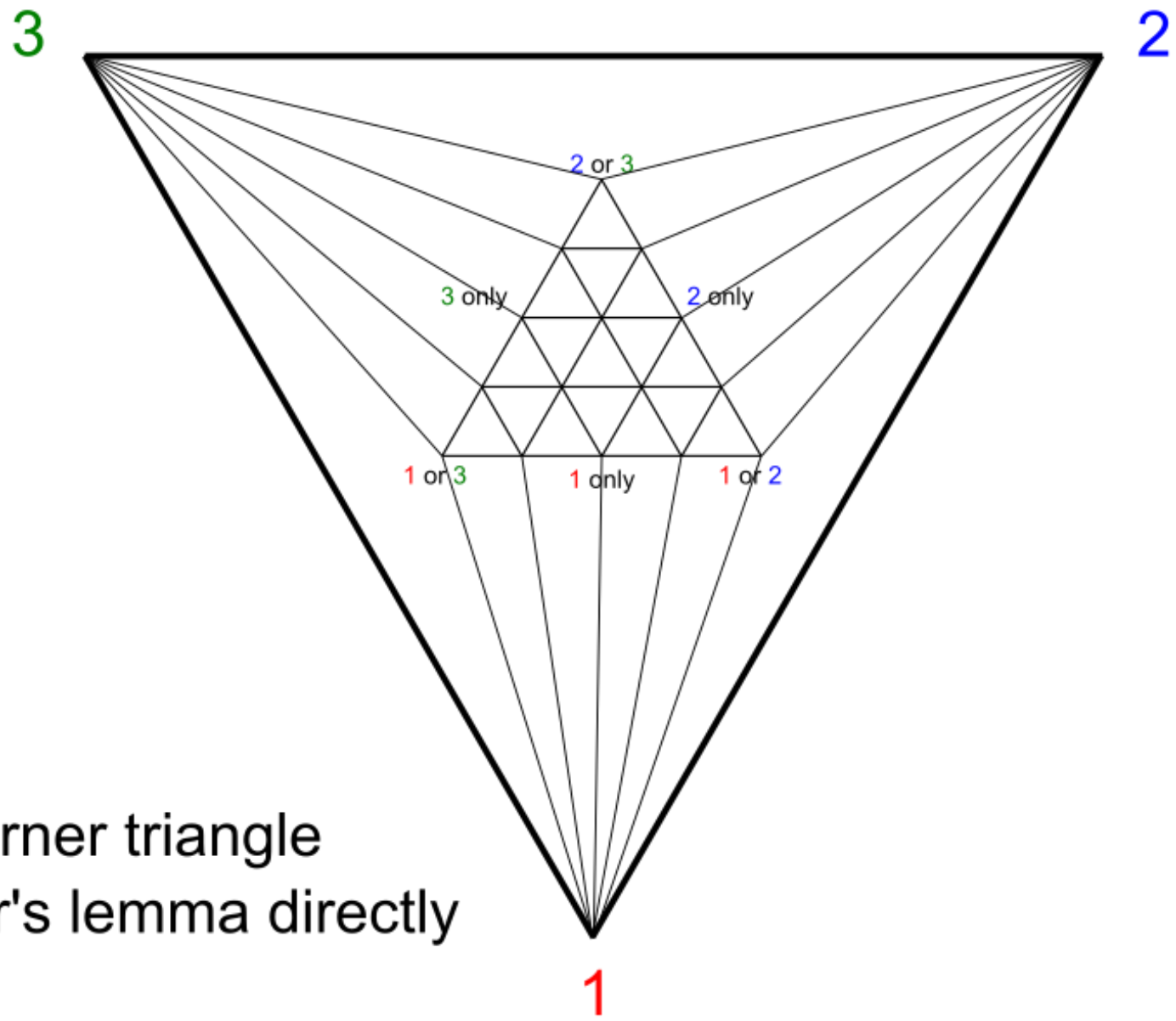

A valid Sperner triangle
⇒ apply Sperner's lemma directly

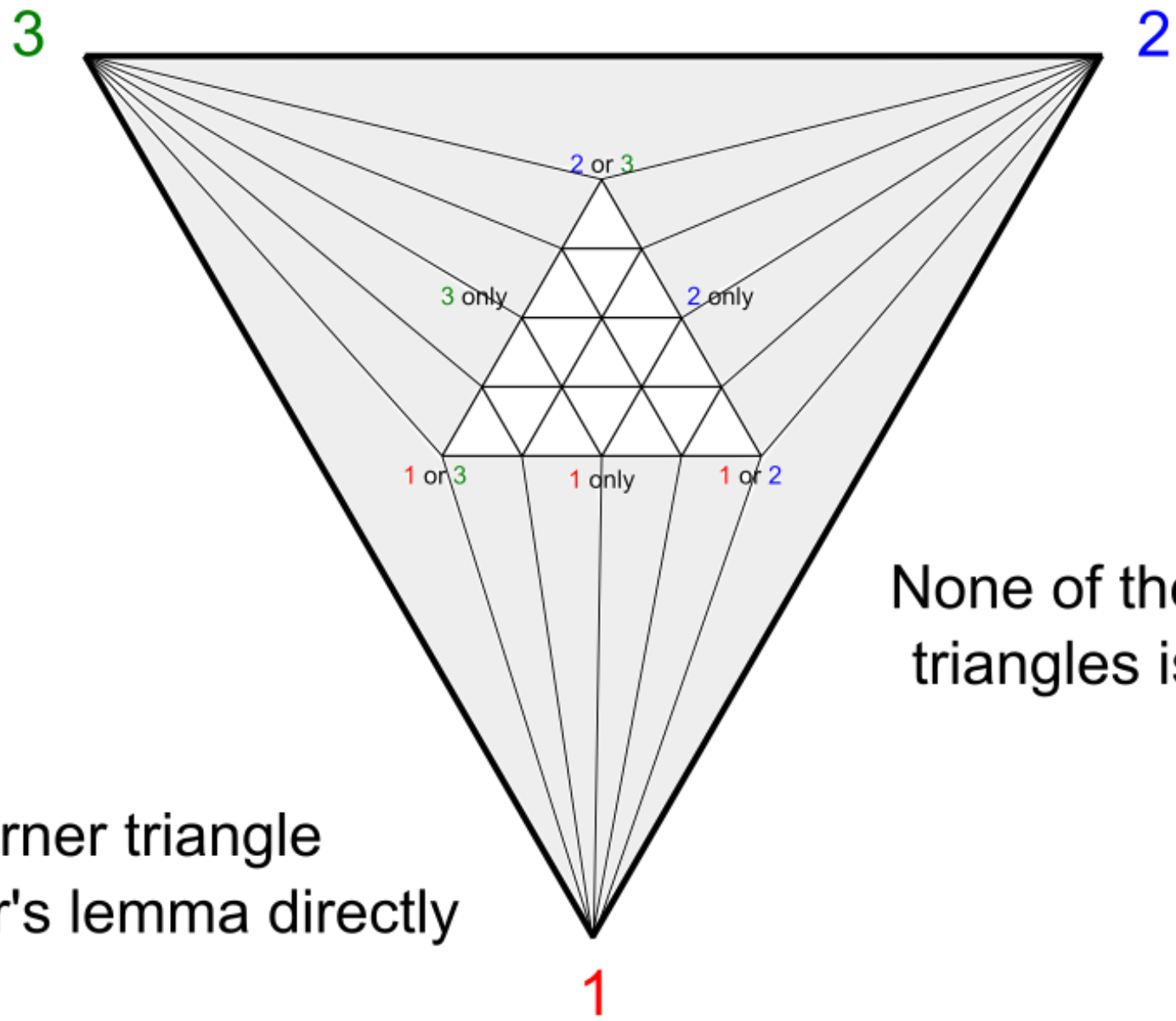

None of the newly added triangles is fully labeled

A valid Sperner triangle
⇒ apply Sperner's lemma directly

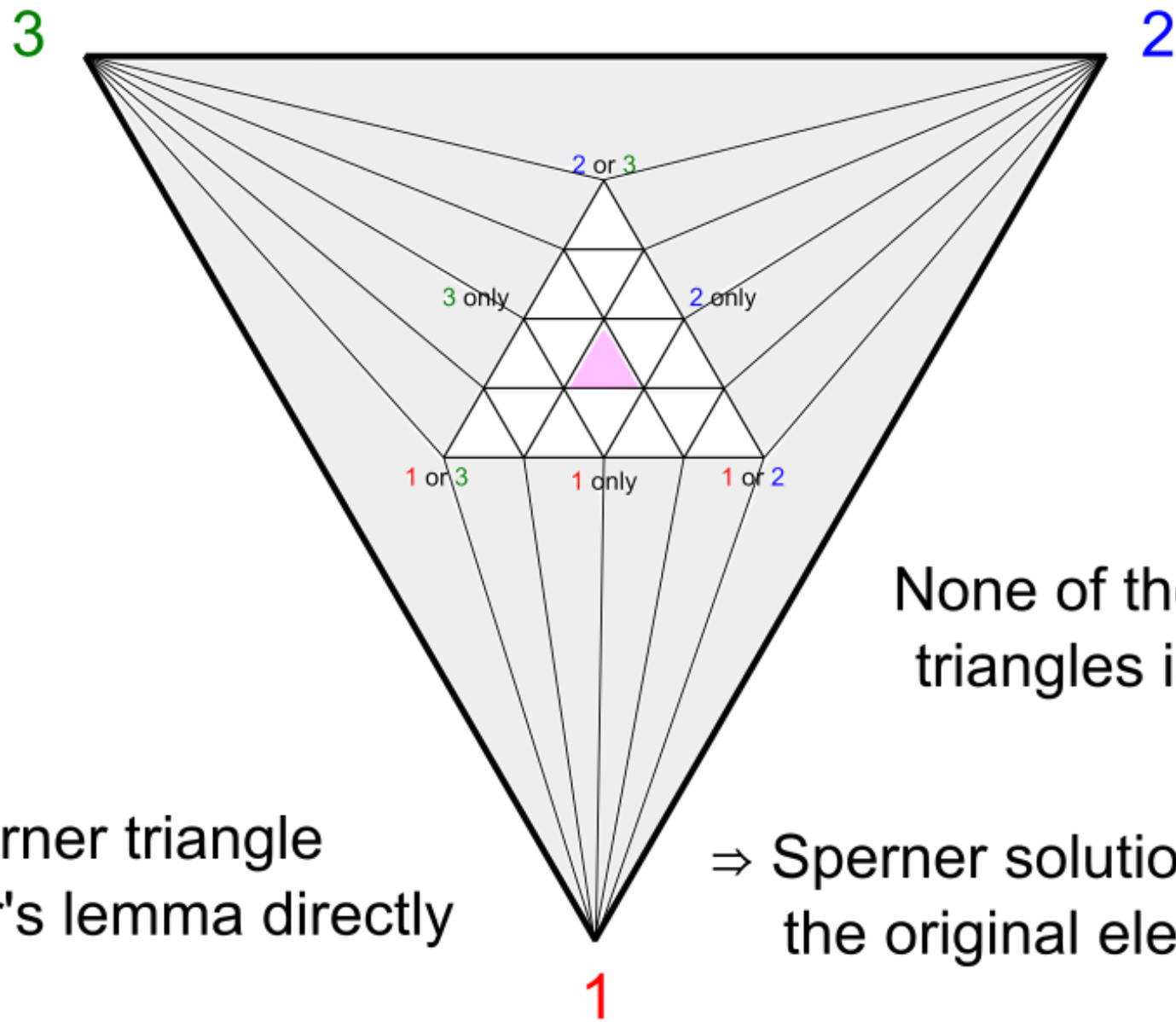

None of the newly added triangles is fully labeled

A valid Sperner triangle
 ⇒ apply Sperner's lemma directly

⇒ Sperner solution must be one of the original elementary triangles

1

Cake Cutting

Rental harmony
via
Sperner's lemma



Fair cake cutting
via
Sperner's lemma
(next lecture)

Rental harmony
via
Sperner's lemma

Other Applications of Sperner's Lemma

Monsky's theorem

A square cannot be dissected into an odd number of triangles with equal area.

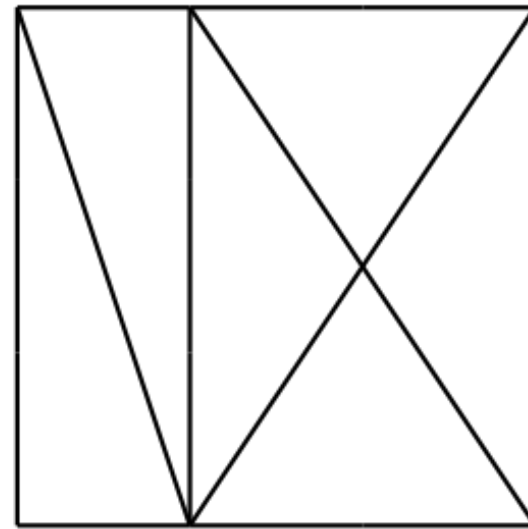
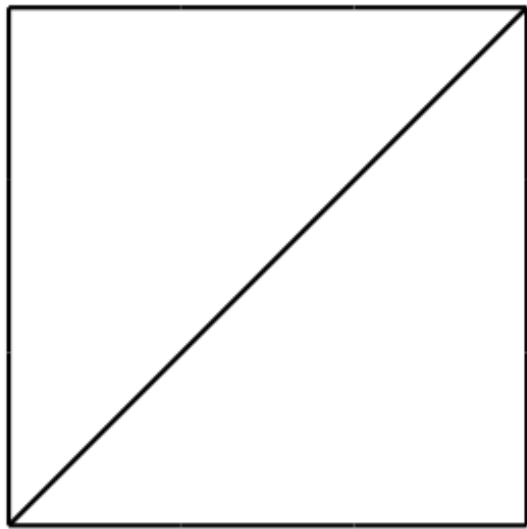

Brouwer's fixed point theorem

Every continuous function from a compact convex set to itself has a fixed point.

Brouwer's fixed point theorem

$$f(x) = x$$

Every continuous function from a compact convex set to itself has a fixed point.

Brouwer's fixed point theorem

$$\curvearrowright f(x) = x$$

Every continuous function from a compact convex set to itself has a fixed point.



Brouwer's fixed point theorem

$$f(x) = x$$

Every continuous function from a compact convex set to itself has a fixed point.



Brouwer's fixed point theorem

$$f(x) = x$$

Every continuous function from a compact convex set to itself has a fixed point.



References

- Fair cake cutting and rent division via Sperner's Lemma

Francis Su

“Rental Harmony: Sperner's Lemma in Fair Division”

American Mathematical Monthly, 106, 1999 pg 930-942

- Fun videos on the topic:

Mathologer: <https://www.youtube.com/watch?v=7s-YM-kcKME>

MoMath: <https://www.youtube.com/watch?v=CBVg8x4LWZE>

PBS Infinite Series: <https://www.youtube.com/watch?v=48oBEvpdYSE>

Proof Sketch of Sperner's Lemma

Proof Sketch of Sperner's Lemma

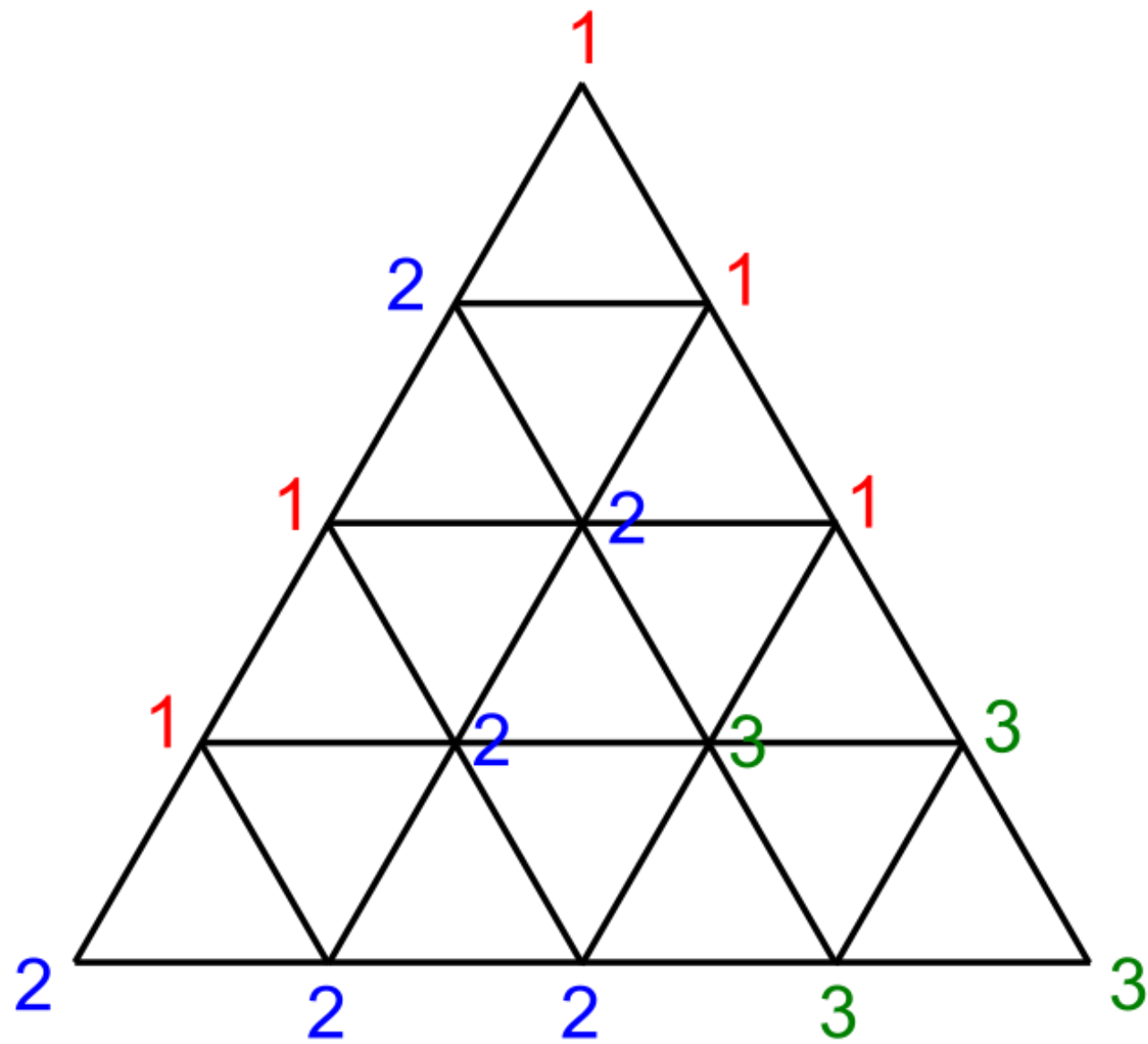

Proof Sketch of Sperner's Lemma

Call any 1—2 edge a "door".

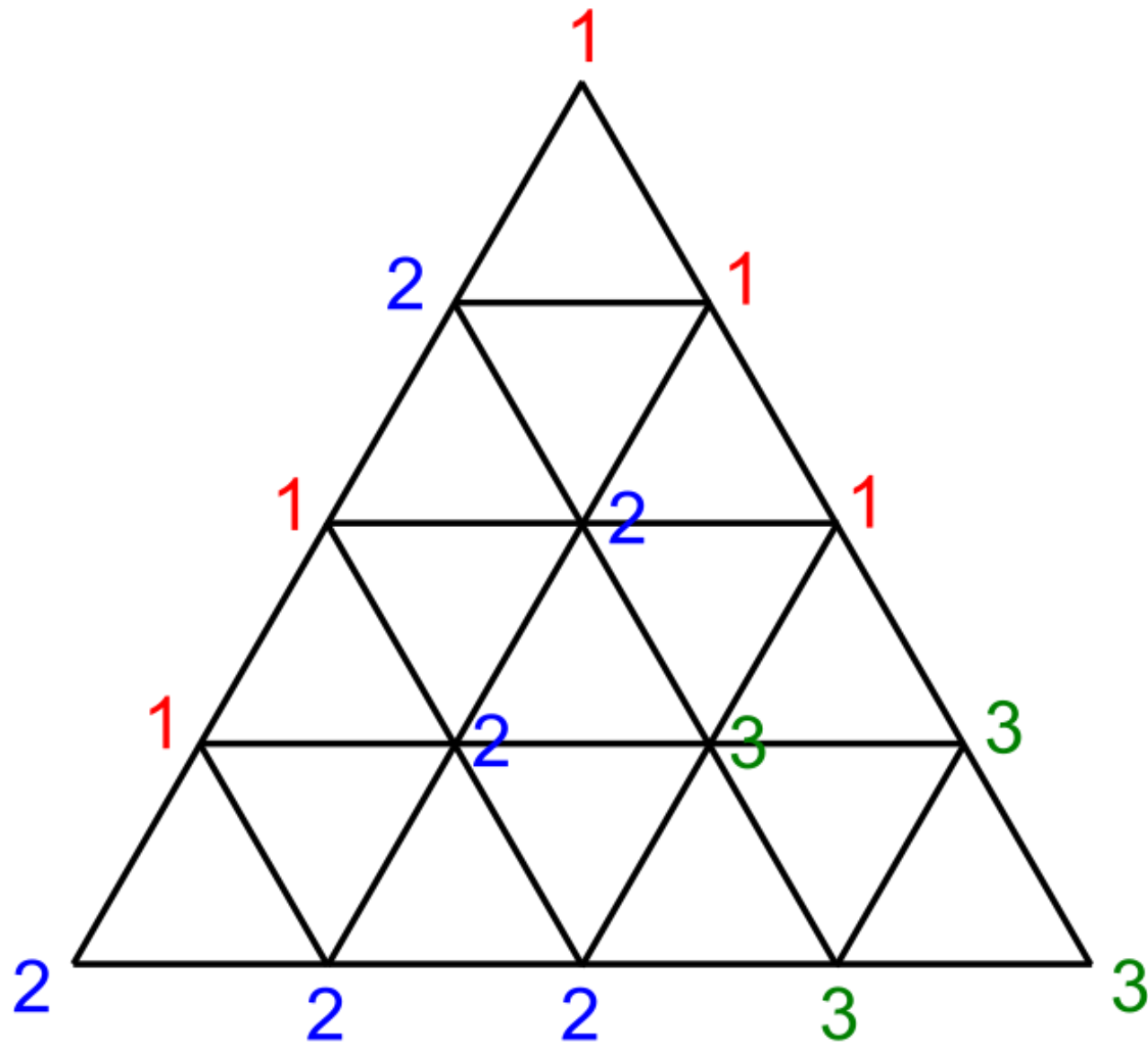

Proof Sketch of Sperner's Lemma

Call any 1—2 edge a "door".

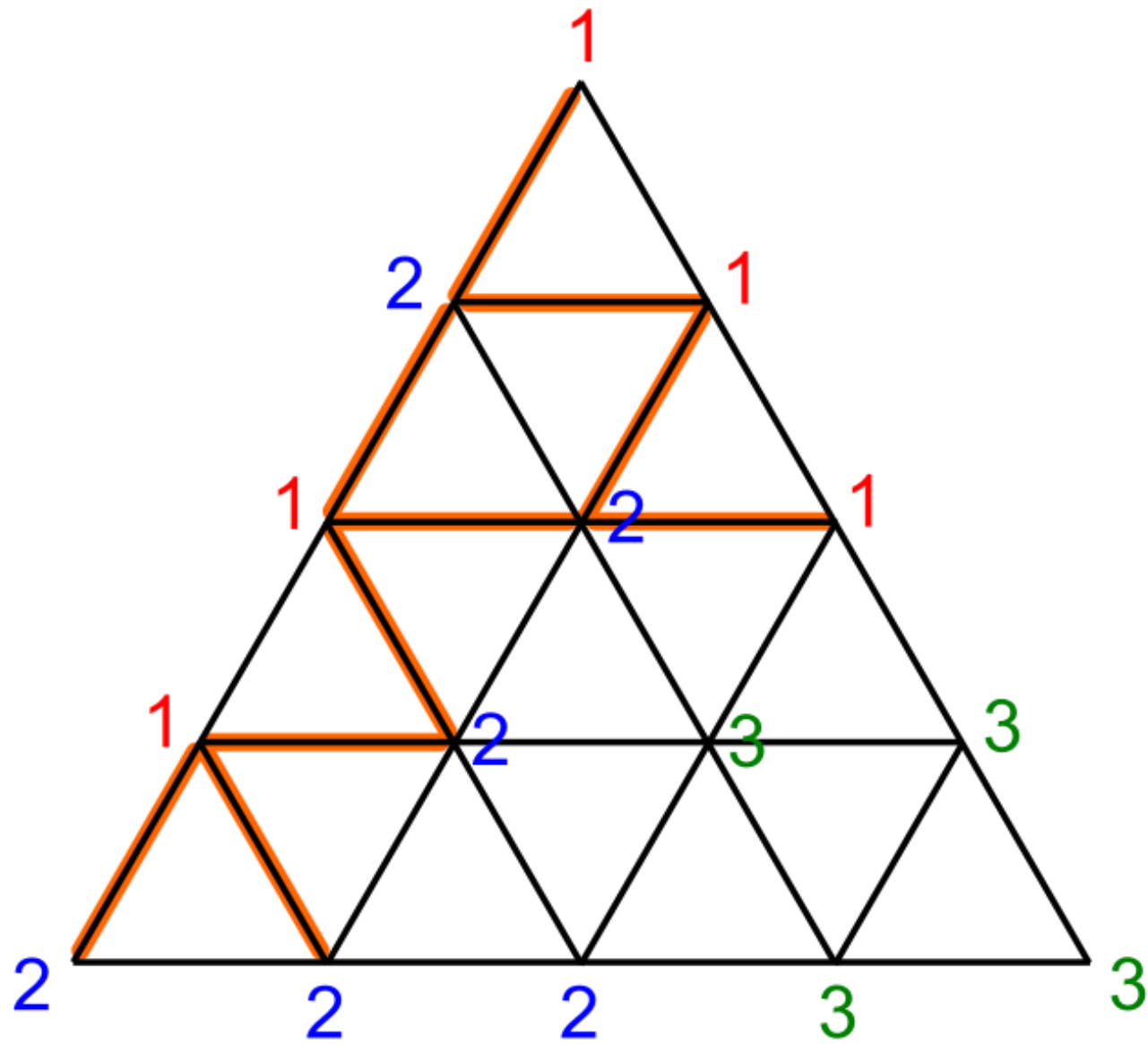

Proof Sketch of Sperner's Lemma

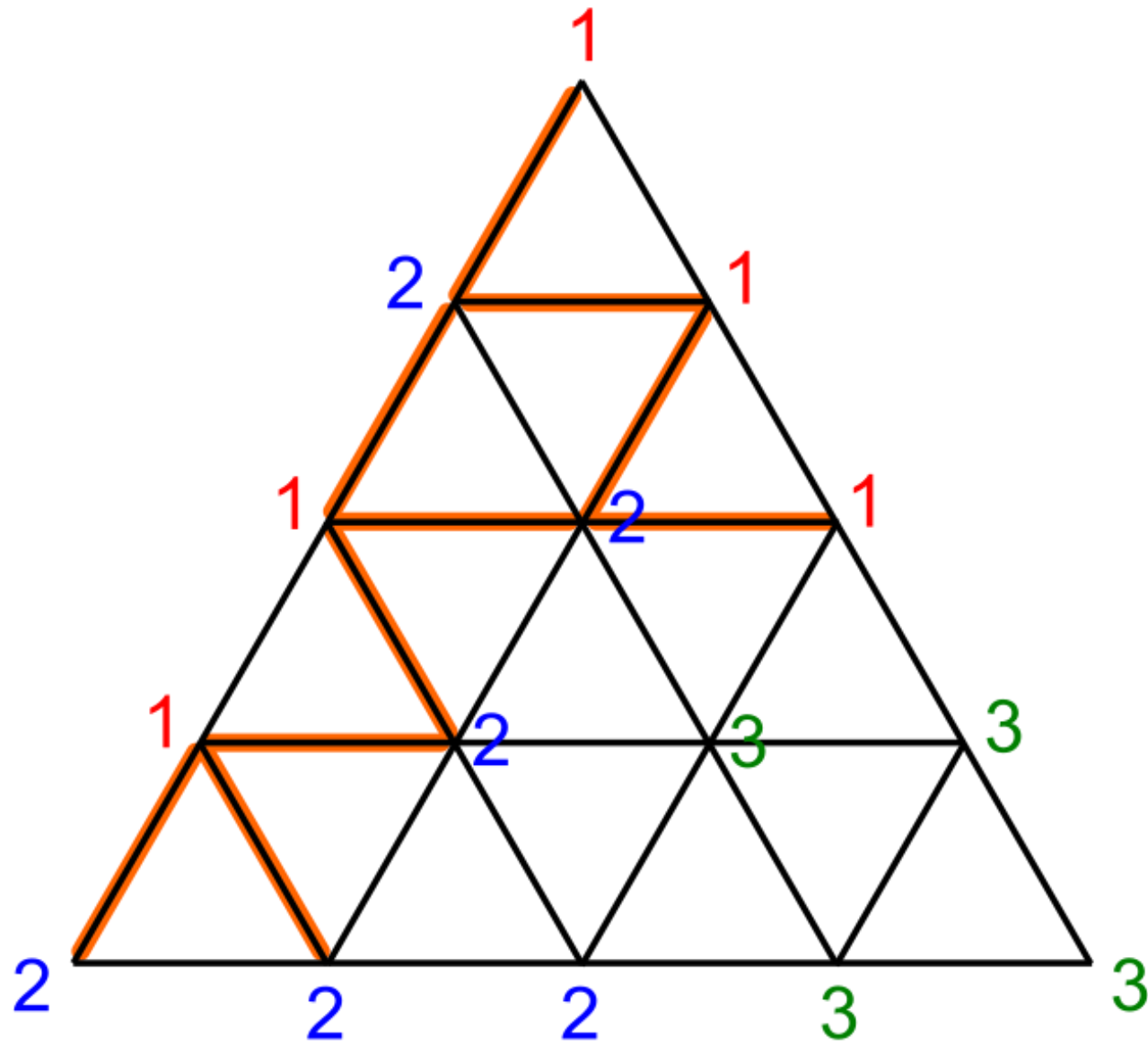

Call any 1—2 edge a "door".

Call any elementary triangle a "room".

Proof Sketch of Sperner's Lemma

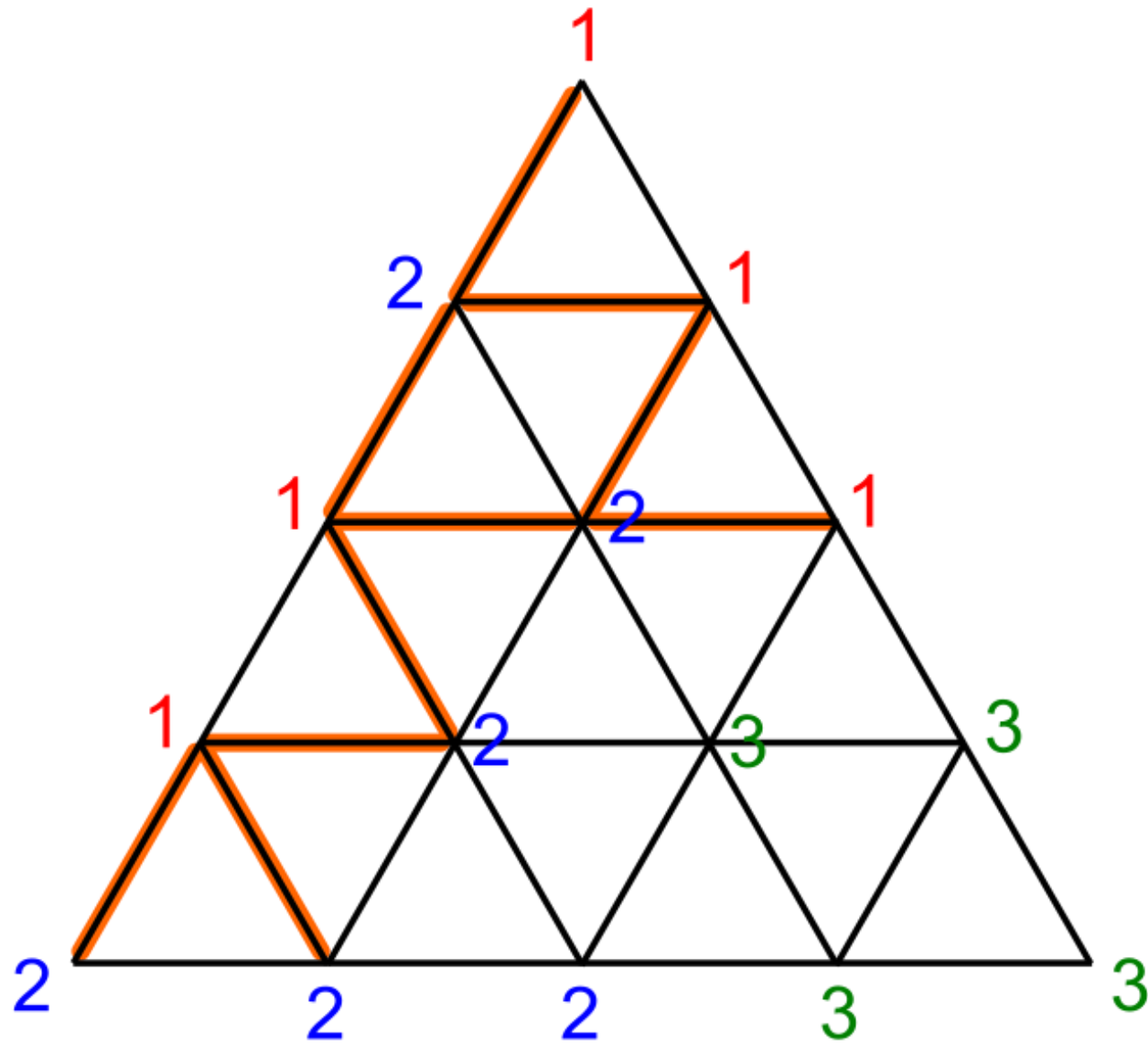

Call any 1—2 edge a "door".

Call any elementary triangle a "room".

Observe:

- No. of doors on the boundary is odd.

Proof Sketch of Sperner's Lemma

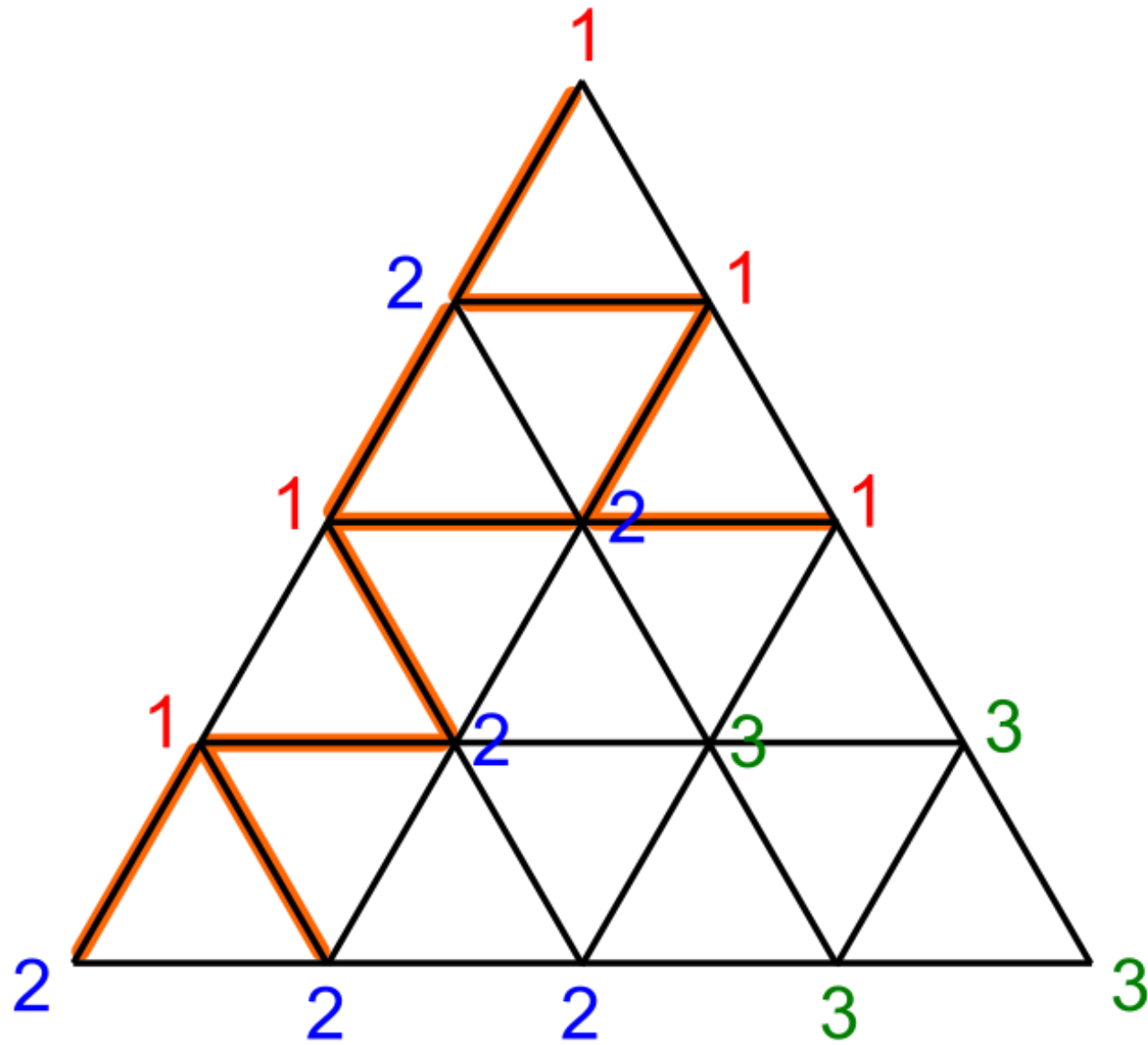

Call any 1—2 edge a "door".

Call any elementary triangle a "room".

Observe:

- No. of doors on the boundary is odd.
- A room can have zero, one, or two doors.

Proof Sketch of Sperner's Lemma

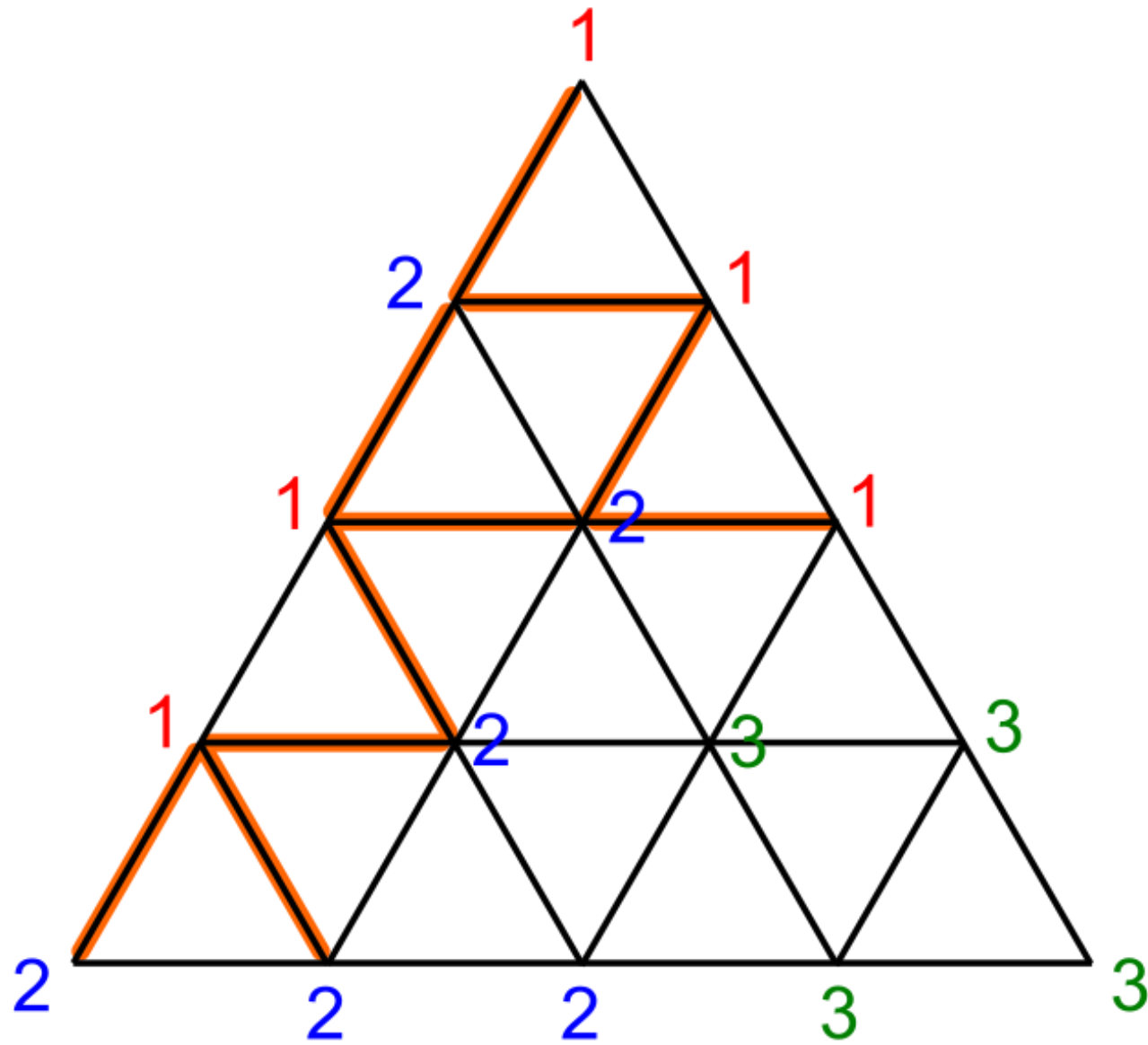

Call any 1—2 edge a "door".

Call any elementary triangle a "room".

Observe:

- No. of doors on the boundary is odd.
- A room can have zero, one, or two doors.

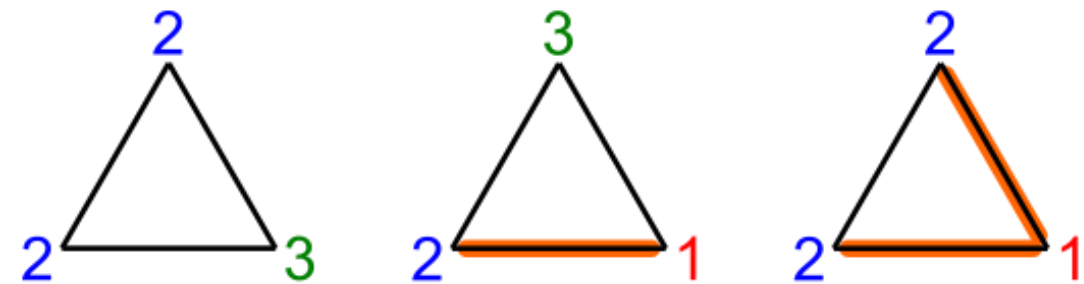

Proof Sketch of Sperner's Lemma

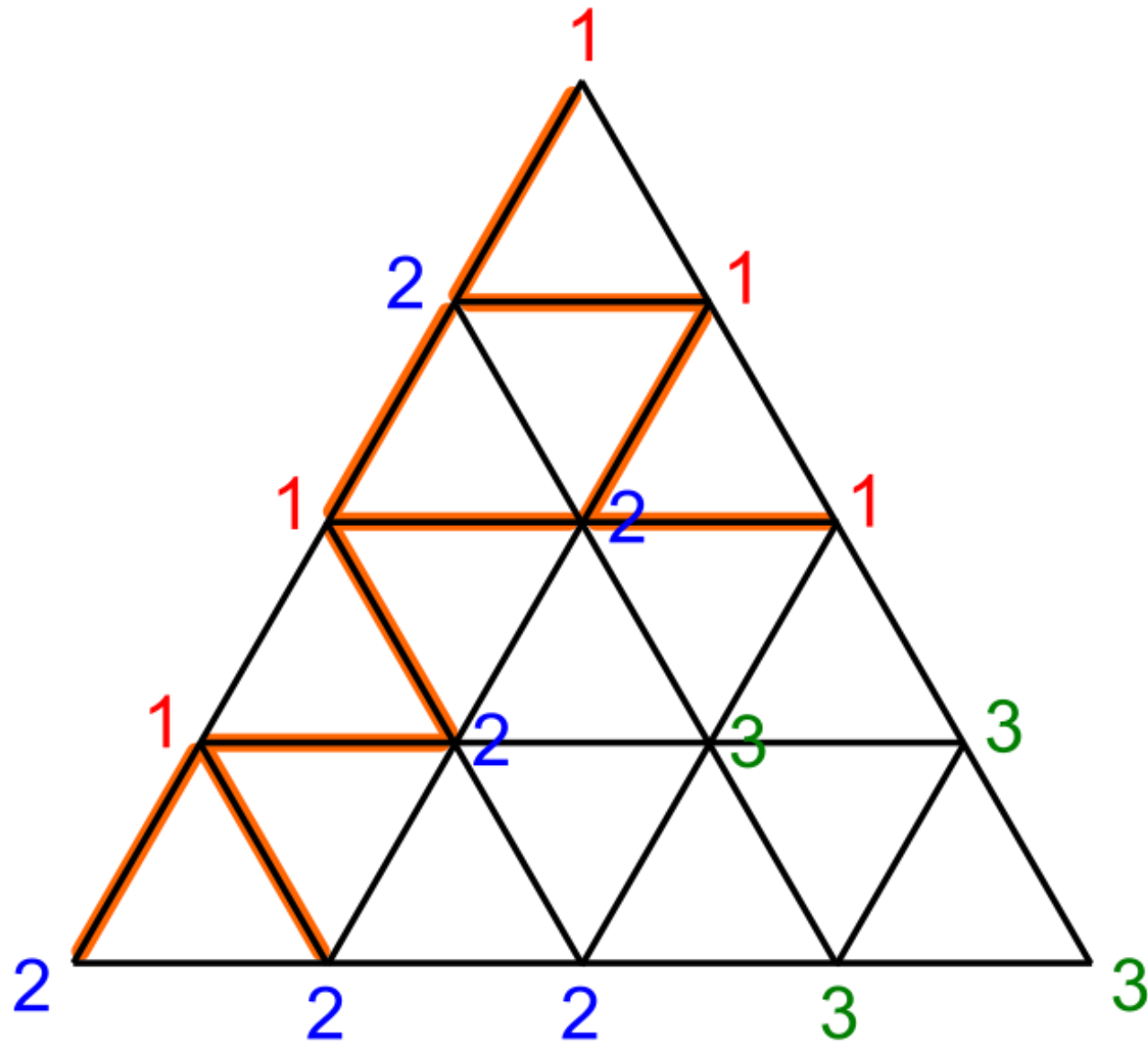

Call any 1—2 edge a "door".

Call any elementary triangle a "room".

Observe:

- No. of doors on the boundary is odd.
- A room can have zero, one, or two doors.

Proof Sketch of Sperner's Lemma

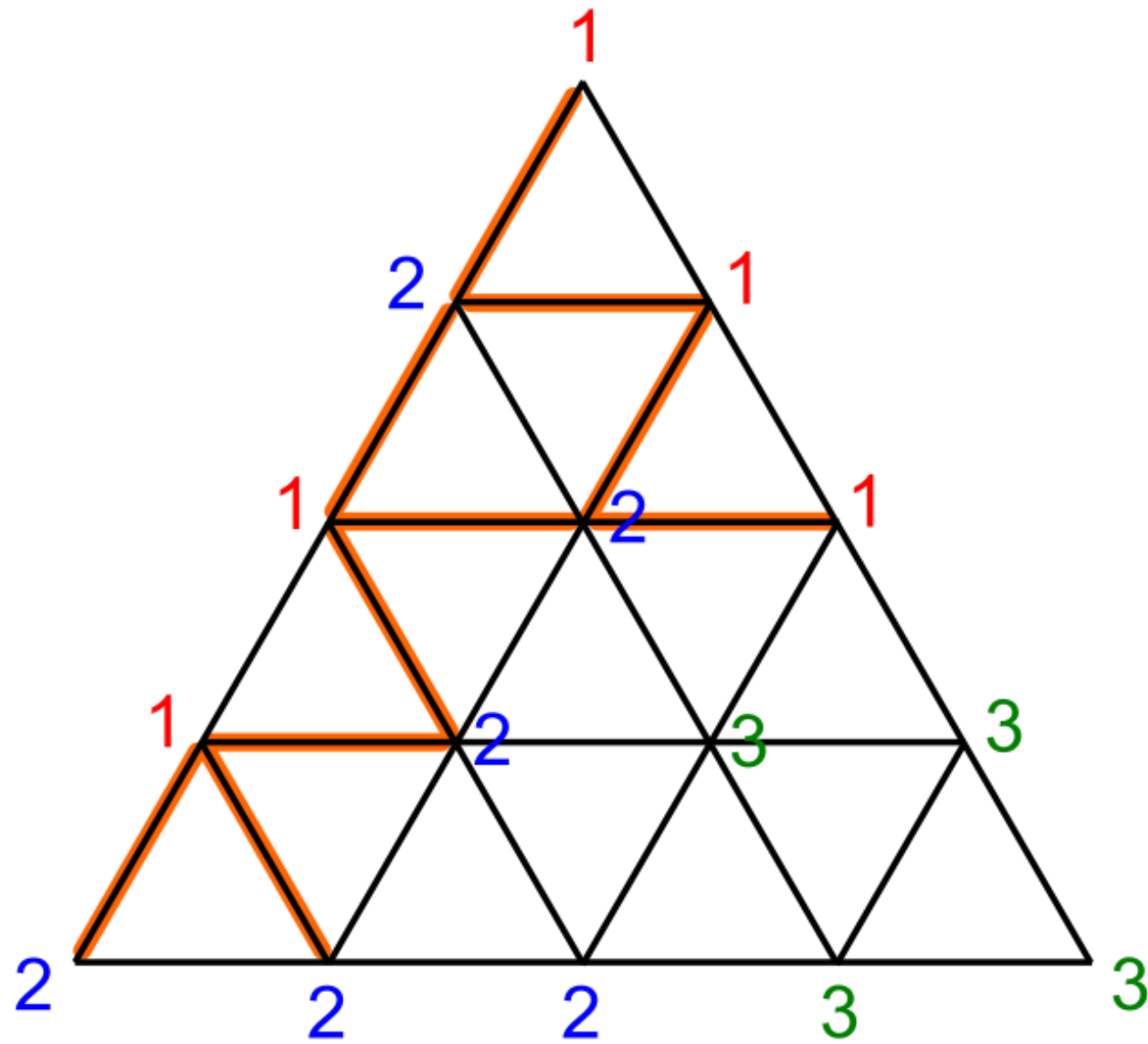

Call any 1—2 edge a "door".

Call any elementary triangle a "room".

Proof Sketch of Sperner's Lemma

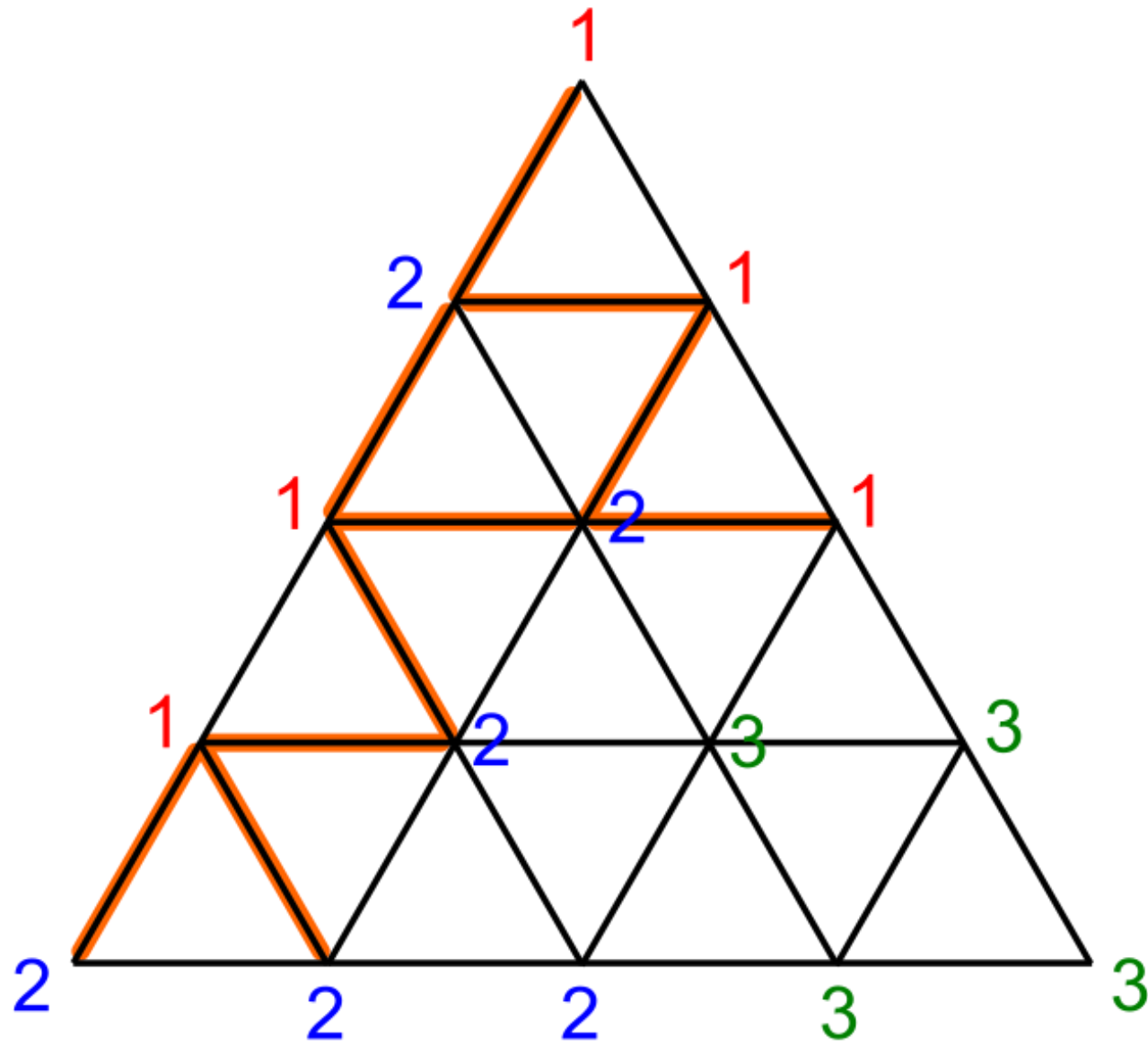

Call any 1—2 edge a "door".

Call any elementary triangle a "room".

Start walking!

Proof Sketch of Sperner's Lemma

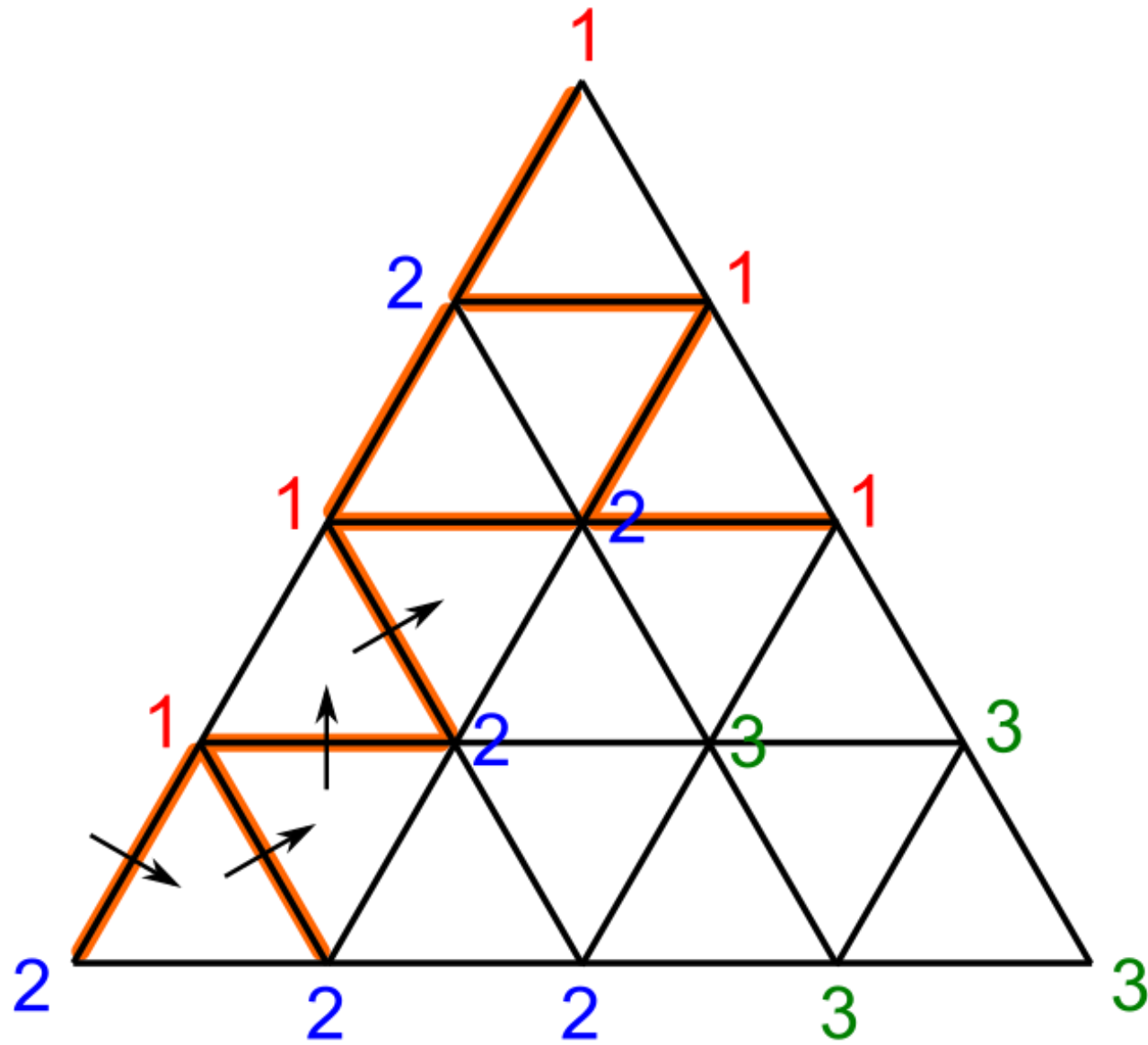

Call any 1—2 edge a "door".

Call any elementary triangle a "room".

Start walking!

Proof Sketch of Sperner's Lemma

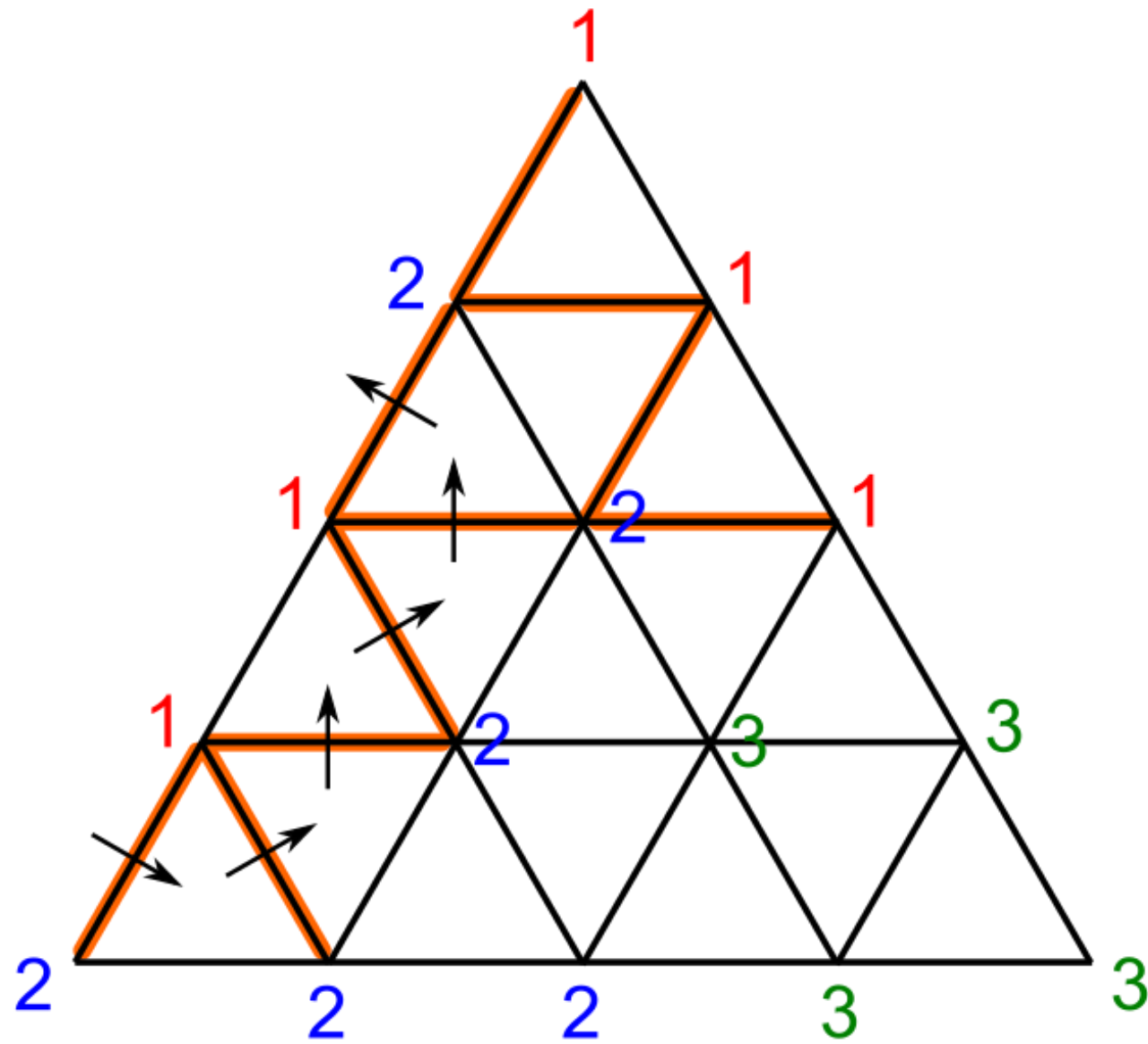

Call any 1—2 edge a "door".

Call any elementary triangle a "room".

Start walking!

Proof Sketch of Sperner's Lemma

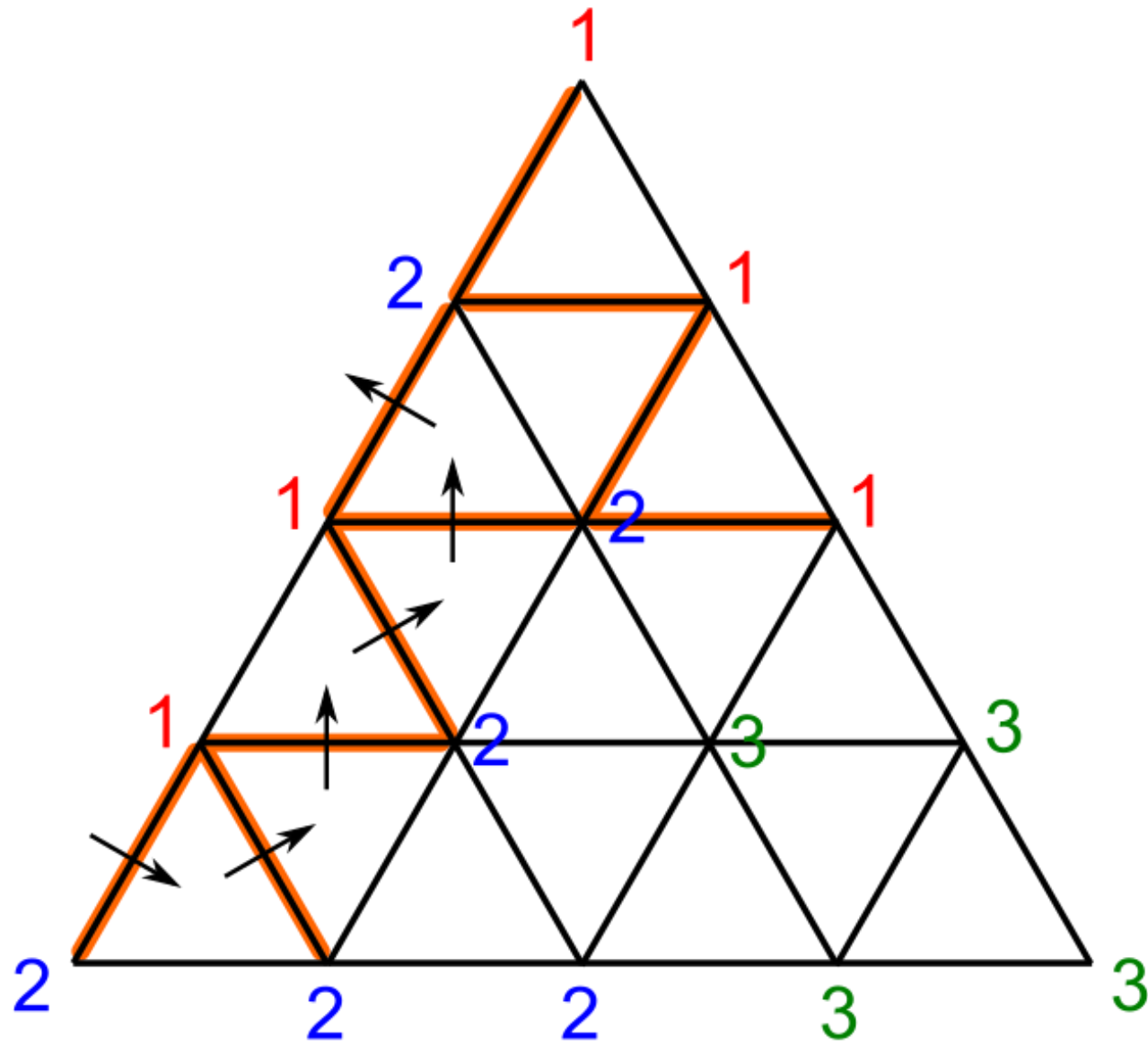

Call any 1—2 edge a "door".

Call any elementary triangle a "room".

Start walking!

- If thrown out, take another door.

Proof Sketch of Sperner's Lemma

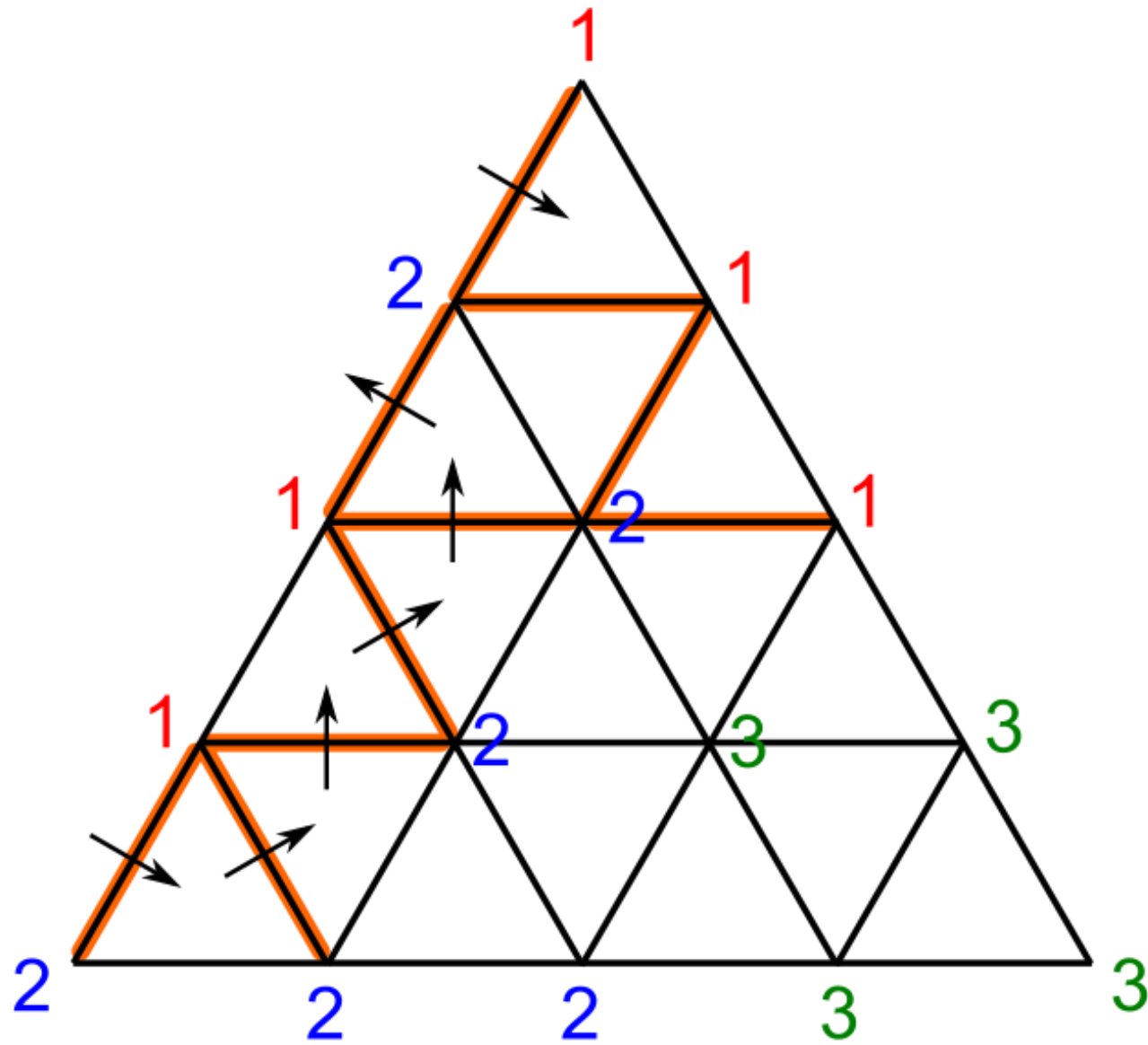

Call any 1—2 edge a "door".

Call any elementary triangle a "room".

Start walking!

- If thrown out, take another door.
- Some path must end up in a room with exactly one door.

Proof Sketch of Sperner's Lemma

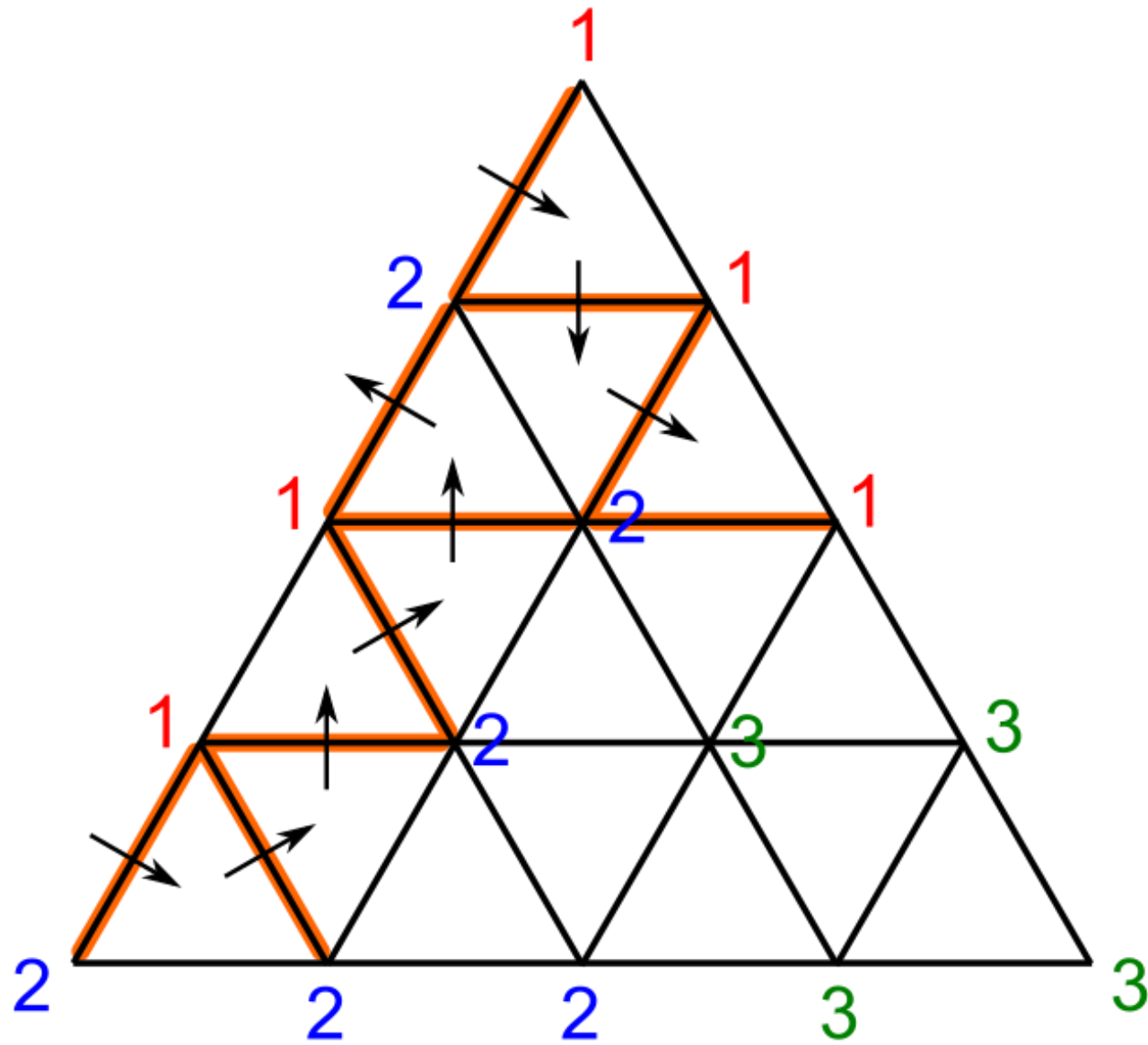

Call any 1—2 edge a "door".

Call any elementary triangle a "room".

Start walking!

- If thrown out, take another door.
- Some path must end up in a room with exactly one door.

Proof Sketch of Sperner's Lemma

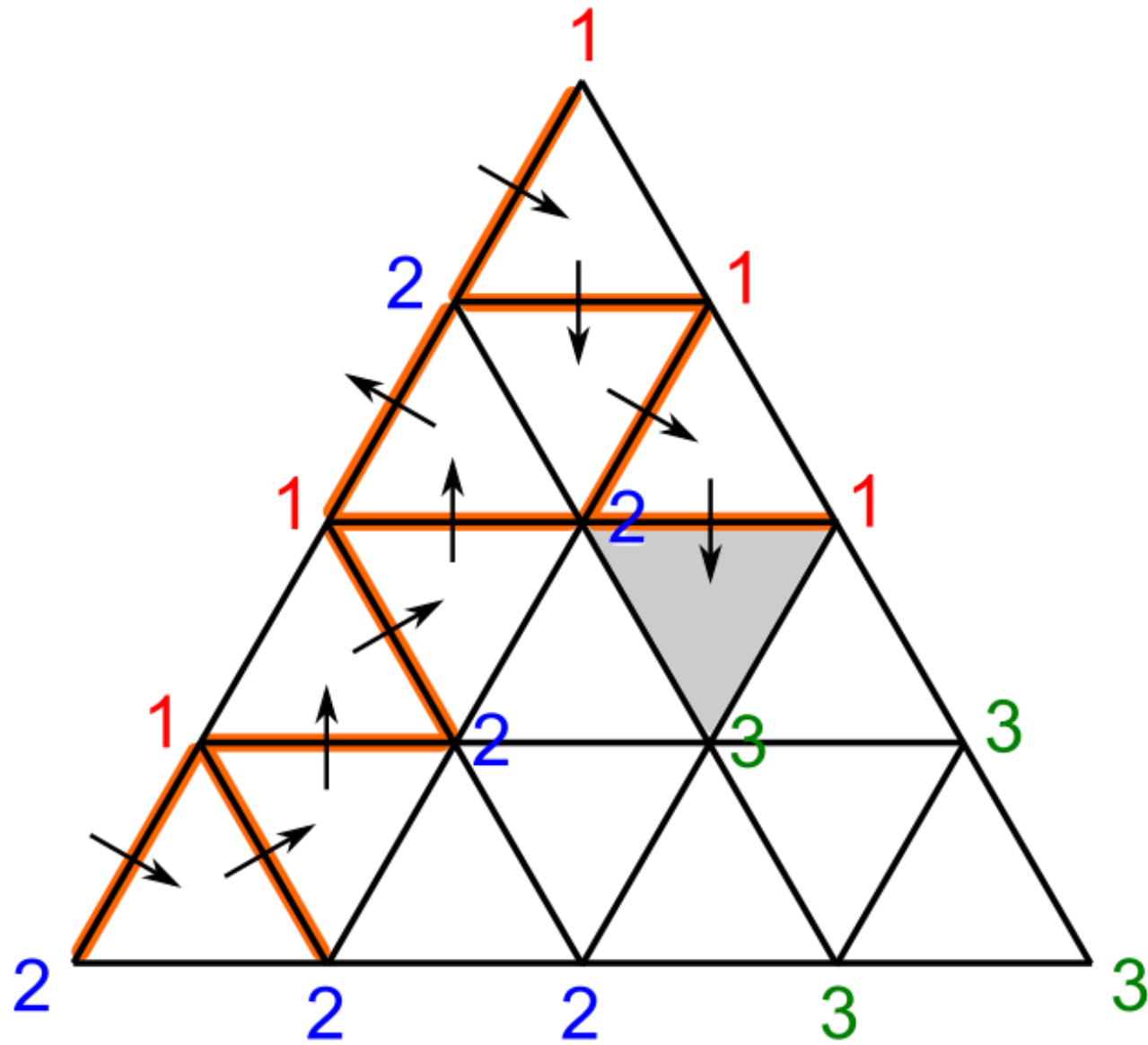

Call any 1—2 edge a "door".

Call any elementary triangle a "room".

Start walking!

- If thrown out, take another door.
- Some path must end up in a room with exactly one door.

Proof Sketch of Sperner's Lemma

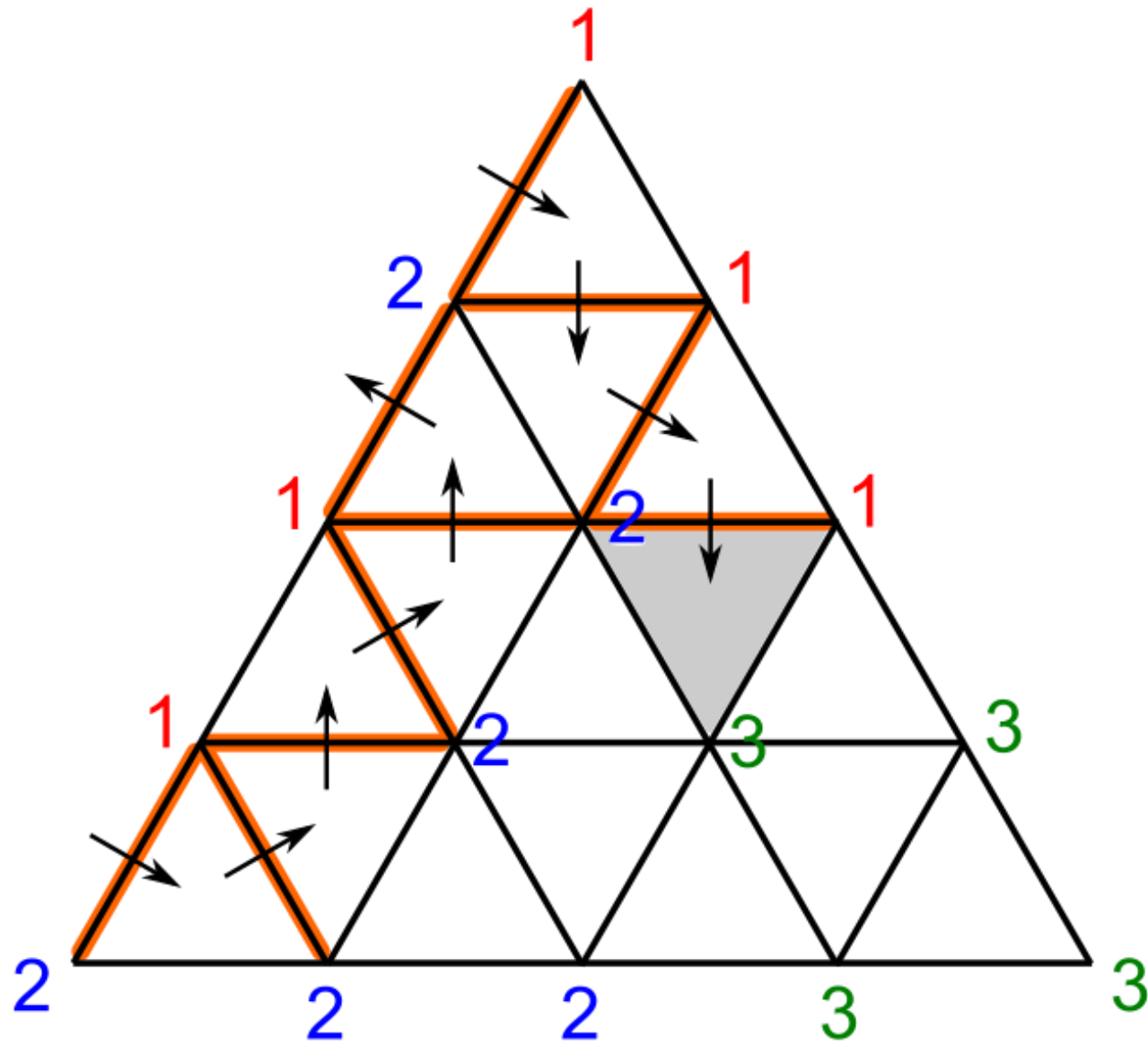

Call any 1—2 edge a "door".

Call any elementary triangle a "room".

Start walking!

- If thrown out, take another door.
- Some path must end up in a room with exactly one door.

Why can't such a walk cycle?

Proof Sketch of Sperner's Lemma

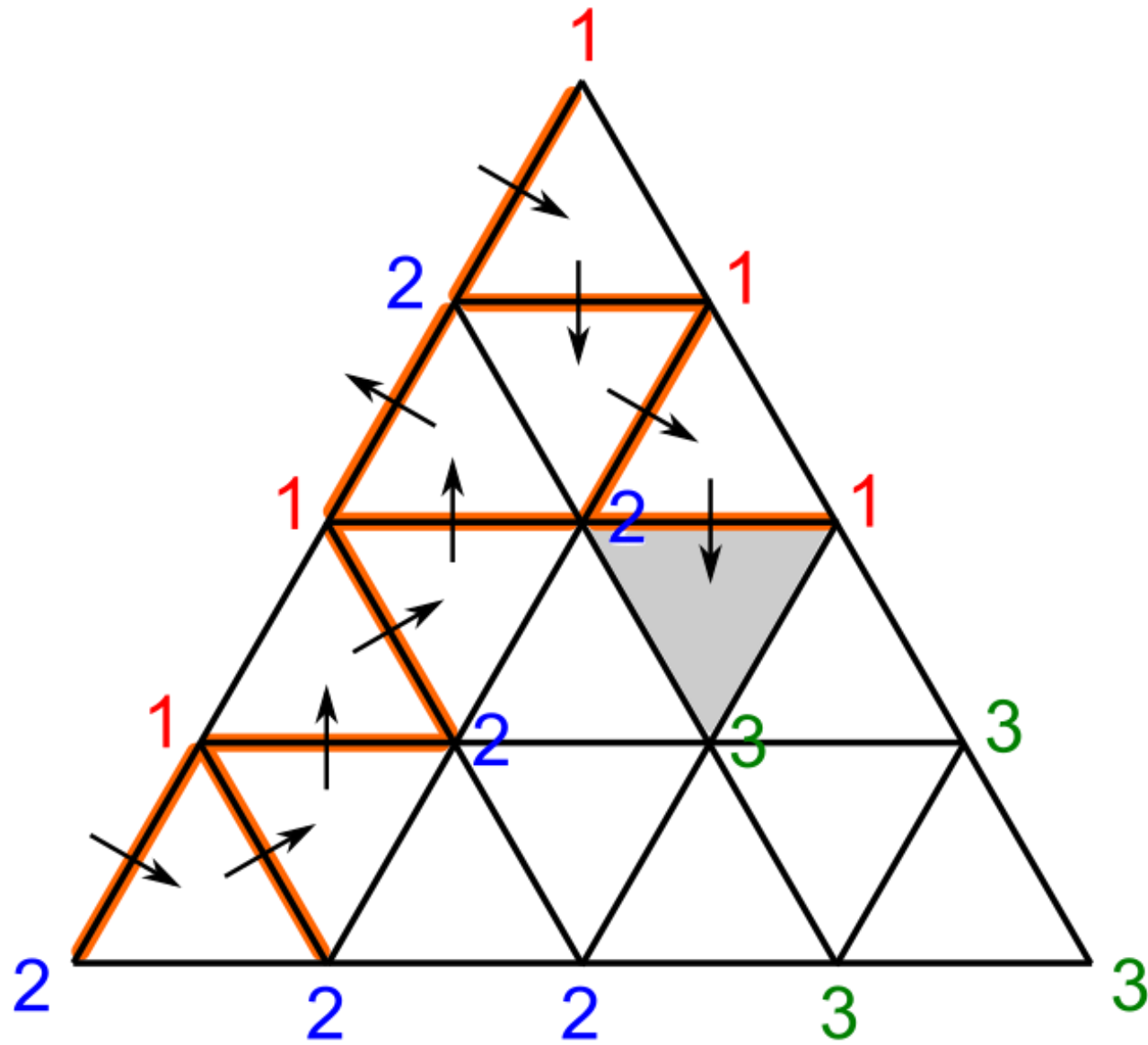

Call any 1—2 edge a "door".

Call any elementary triangle a "room".

Start walking!

- If thrown out, take another door.
- Some path must end up in a room with exactly one door.

Why can't such a walk cycle? Exercise.

Proof Sketch of Sperner's Lemma

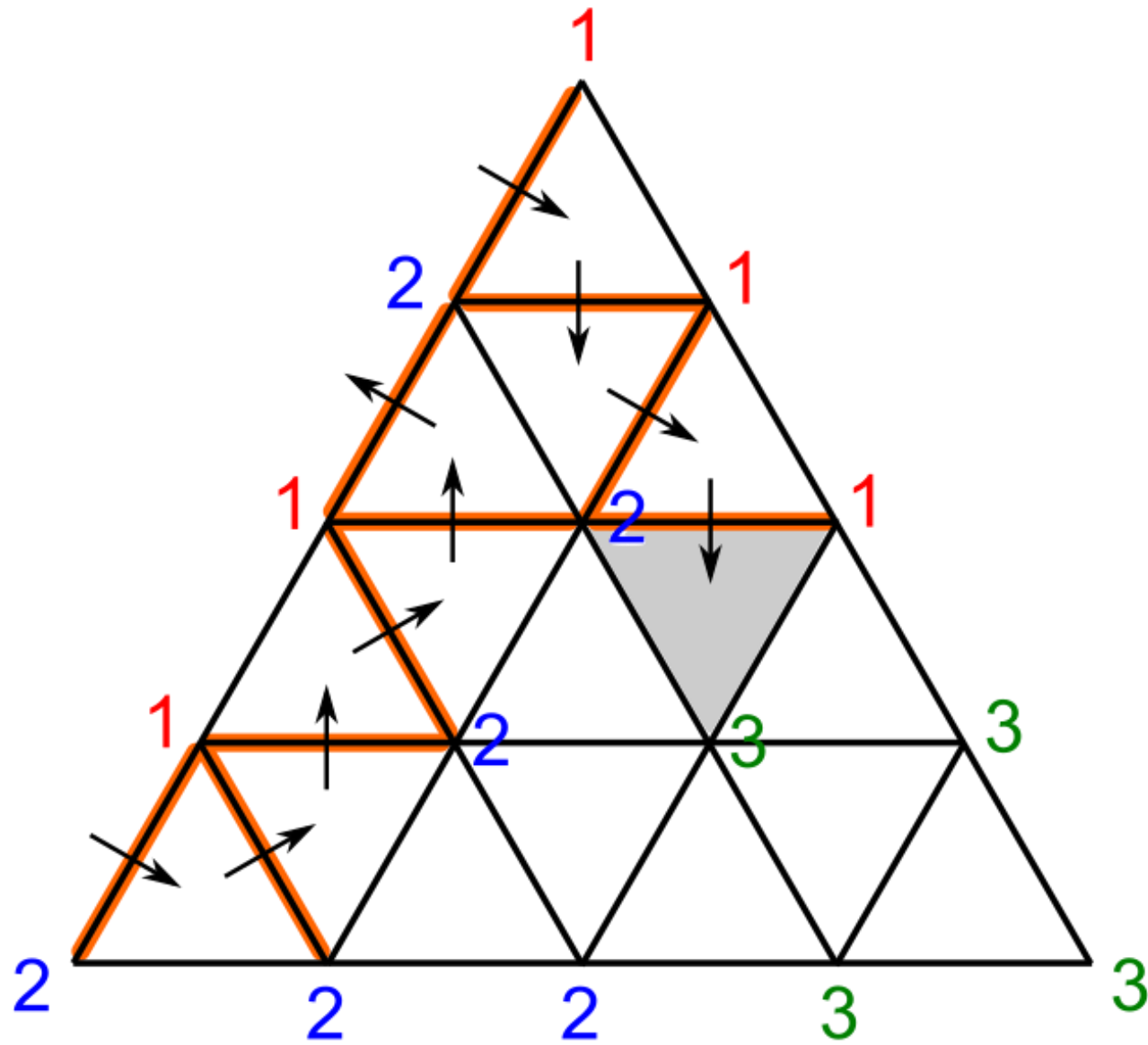

Call any 1—2 edge a "door".

Call any elementary triangle a "room".

Start walking!

- If thrown out, take another door.
- Some path must end up in a room with exactly one door.

Why can't such a walk cycle? Exercise.



